

# AI Auto Tracking PTZ Camera

## — User Manual —

TR211 / TR315 / TR315N / TR335 / TR335N

## Warning

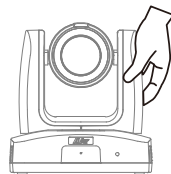
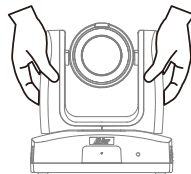
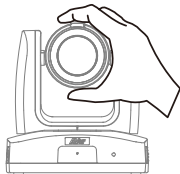
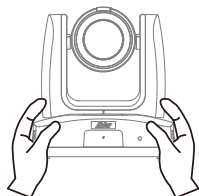

- Hold the bottom of the camera with both hands to carry the camera. Whether the camera is connected to power or not, do not grab any part of the lens or the lens holder to carry the camera or adjust pan and tilt.
- Do not drop the camera or subject it to physical shock.
- Ensure the power supply voltage is correct before using the camera.
- Do not place the camera where the cord can be stepped on as this may result in fraying or damage to the lead or the plug.
- To reduce the risk of fire or electric shock, do not expose the camera to rain or moisture. Warranty will be voided if any unauthorized modifications are done to the camera.

### Federal Communications Commission

NOTE: This equipment has been tested and found to comply with the limits for a Class A digital device, pursuant to part 15 of the FCC Rules. These limits are designed to provide reasonable protection against harmful interference when the equipment is operated in a commercial environment. This equipment generates, uses, and can radiate radiofrequency energy and, if not installed and used in accordance with the instruction manual, may cause harmful interference to radio communications. Operation of this equipment in a residential area is likely to cause harmful interference in which case the user will be required to correct the interference at his own expense.

FCC Caution: Any changes or modifications not expressly approved by the party responsible for compliance could void the user's authority to operate this equipment.

This device complies with part 15 of the FCC Rules.

Operation is subject to the following two conditions:

- (1) This device may not cause harmful interference, and
- (2) this device must accept any interference received, including interference that may cause undesired operation.

This Class A digital apparatus complies with Canadian ICES-003. Cet appareil numérique de la classe A est conforme à la norme NMB-003 du Canada.

**Warning**

This is a class A product. In a domestic environment, this product may cause radio interference in which case the user may be required to take adequate measures.

**Caution**

Risk of Explosion if Battery is replaced by an Incorrect Type. Dispose of Used Batteries According to the Instructions.

**DISCLAIMER**

No warranty or representation, either expressed or implied, is made with respect to the contents of this documentation, its quality, performance, merchantability, or fitness for a particular purpose. Information presented in this documentation has been carefully checked for reliability; however, no responsibility is assumed for inaccuracies. The information contained in this documentation is subject to change without notice.

In no event will AVer Information Inc. be liable for direct, indirect, special, incidental, or consequential damages arising out of the use or inability to use this product or documentation, even if advised of the possibility of such damages.

**TRADEMARKS**

“AVer” is a trademark owned by AVer Information Inc. Other trademarks used herein for description purpose only belong to each of their companies.

All HDMI trademarks and trade dress are registered trademarks or trademarks of HDMI Licensing Administrator, Inc.

**COPYRIGHT**

©2026 AVer Information Inc. All rights reserved. | March 17, 2026

All rights of this object belong to AVer Information Inc. Reproduced or transmitted in any form or by any means without the prior written permission of AVer Information Inc. is prohibited. All information or specifications are subject to change without prior notice.

## More Help

For FAQs, technical support, software and user manual download, please visit:

## Non-USA

Download Center: <https://www.aver.com/download-center>

Technical Support: <https://www.aver.com/technical-support>

## USA

Download Center: <https://www.averusa.com/pro-av/support>

Technical Support: <https://averusa.force.com/support/s/contactsupport>

## Contact Information

### Headquarters

AVer Information Inc.  
8F, No.157, Da-An Rd.,  
Tucheng Dist., New Taipei City  
236042, Taiwan  
Tel: +886 (2) 2269 8535

### USA Branch Office

AVer Information Inc., Americas  
44061 Nobel Drive, Fremont, CA  
94538, USA  
Tel: +1 (408) 263 3828  
Toll-free: +1 (877) 528 7824

### Europe Branch Office

AVer Information Europe B.V.  
Westblaak 134, 3012 KM,  
Rotterdam, The Netherlands  
Tel: +31 (0) 10 7600 550

### Japan Branch Office

アバー・インフォメーション株式会社  
〒160-0023 日本東京都新宿区  
西新宿 3-2-26 立花新宿ビル  
7 階  
Tel: +81 (0) 3 5989 0290  
お客様サポートセンター(固定電  
話のみ): +81 (0) 120 008 382

### Vietnam Branch Office

Công ty TNHH AVer Information  
(Việt Nam)  
Tầng 5, 596 Nguyễn Đình  
Chiểu, P.3, Quận 3, Thành phố  
Hồ Chí Minh 700000, Việt Nam  
Tel: +84 (0) 28 22 539 211  
Hỗ trợ kỹ thuật: +84 (0) 90 70  
080 77

### Korea Office

한국 에버 인포메이션 (주)  
서울시 종로구 새문안로 92  
(신문로 1 가,  
광화문오피시아빌딩) 1831,  
1832 호  
Tel: +82 (0) 2 722 8535

# Contents

<b>Warning</b> .....	<b>1</b>
<b>Overview</b> .....	<b>1</b>
Package Contents .....	1
Optional Accessories .....	1
Parts Info .....	2
LED Indicators .....	3
Dimensions .....	3
Pan and Tilt Angle.....	5
Remote Control.....	6
Shortcuts .....	7
<b>Installation</b> .....	<b>8</b>
Mounting Measurements .....	8
Cable Fixing Plate Installation .....	8
Ceiling Mount Installation .....	9
<b>Connections</b> .....	<b>10</b>
Device Connection.....	10
PoE Connection.....	10
RS-232 Connection .....	11
RS-422 Connection .....	13
Audio Input Connection .....	15
Video Output Connection.....	15
<b>Get Started</b> .....	<b>16</b>
Power the Device On and Off.....	16

Reset the Device .....	16
Factory Default Settings .....	16
Access the OSD Menu .....	16
Change Your Network Setting .....	17
OSD Menu Tree .....	19
Access the Web Interface .....	21
AVer Device Utility .....	21
AVer Enterprise Management .....	22
Log in for the First Time .....	22
<b>Web Interface .....</b>	<b>23</b>
Live View .....	23
Camera Control .....	23
Preset .....	24
Camera Settings .....	26
Exposure .....	26
Image Process .....	27
Image Quality (IQ) .....	28
Video & Audio .....	29
Output Interface Table .....	30
Network .....	32
Tracking Settings .....	36
Compare Tracking Modes .....	37
Tracking Control Panel .....	38
Presenter Mode .....	39
Zone Mode .....	42
Hybrid Mode .....	45
Framing .....	48

Gesture (Beta).....	50
Face Enrollment .....	51
NDI.....	53
System.....	55
Audio Integrated .....	58
Supported Microphones .....	58
<b>Appendix.....</b>	<b>59</b>
VISCA RS-232 Commands .....	59
VISCA over IP Settings.....	65
CGI Commands .....	66
Pelco P Commands .....	71
Pelco D Commands.....	71

# Overview

## Package Contents

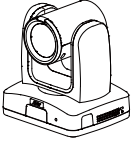

Camera

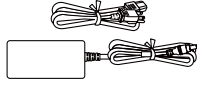

Power Adapter & Power Cord

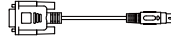

DIN8 to D-Sub9 Cable



RS-232 In/Out Y Cable

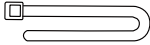

Cable Ties (x4)



Remote Control

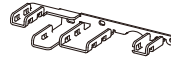

Cable Fixing Plate

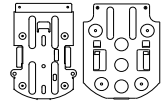

Ceiling Mount Bracket (x2)



M2 x 4mm Screw (x3)



M3 x 6mm Screw (x3)



1/4\"-20, L=6.5mm Screw (x2)



Drill Template

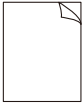

Quick Start Guide

## Optional Accessories

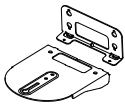

Wall Mount Bracket

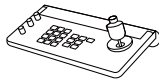

Camera Controller (CL01)

\* For details on optional accessories, please consult with your local dealer.

# Parts Info

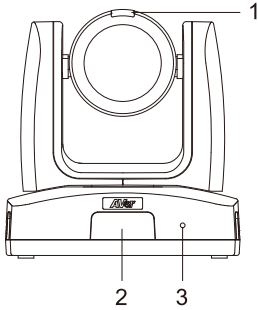

1. Tally Lamp
2. IR Sensor
3. LED Indicator

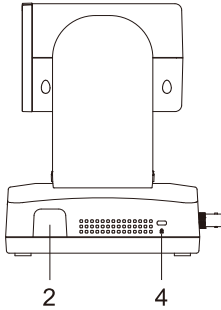

4. Kensington Lock

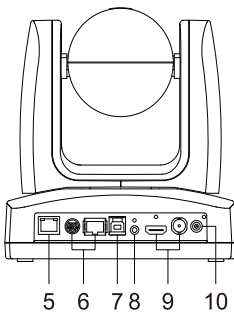

5. PoE+ 802.3at Port
6. Control Ports  
RS-232 / RS-422
7. USB 3.0 Type-B Port
8. Audio In  
Line input level: 1Vrms max.  
Mic input level: 50mVrms max.; supplied voltage: 2.5V.
9. Video Output Ports  
HDMI® / 3G-SDI
10. DC Power Jack

# LED Indicators

Color	Status
Flashing orange	Start-up
Solid orange	Standby
Solid blue	Operational
Flashing blue	Auto Tracking on
Flashing purple	Gesture recognition
Flashing red	Firmware update

# Dimensions

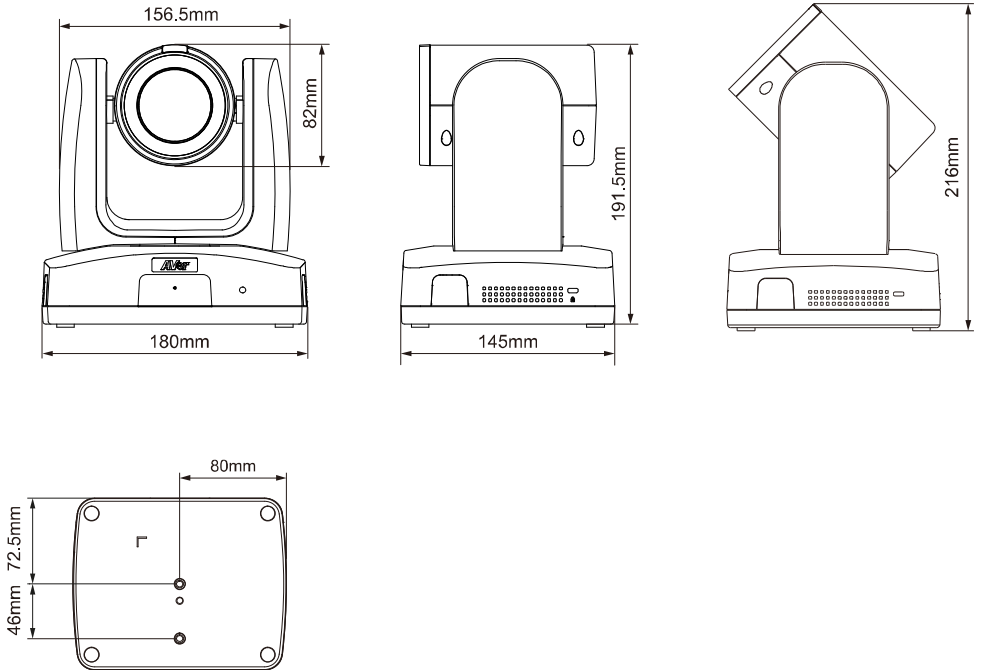

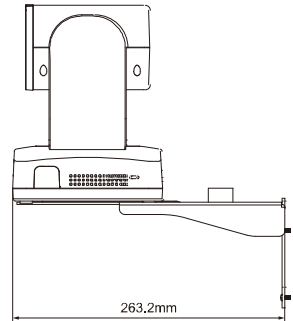
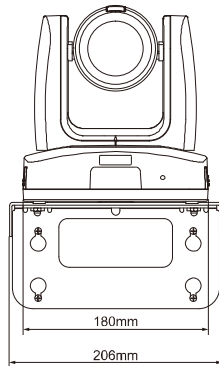
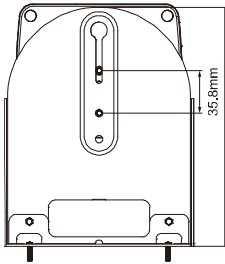
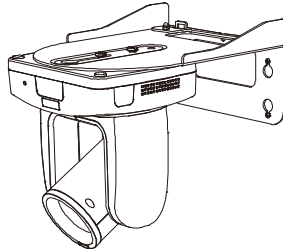
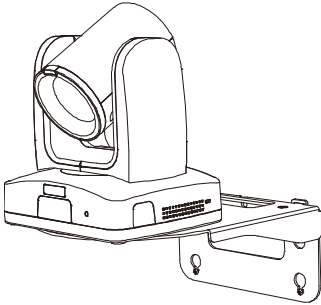
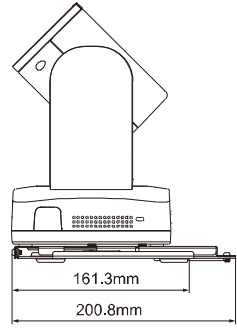
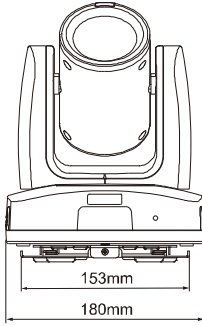
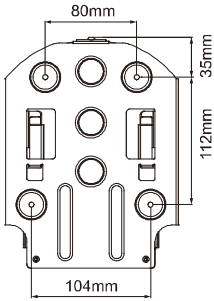
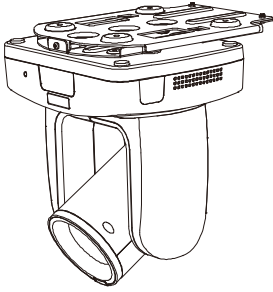

## Pan and Tilt Angle

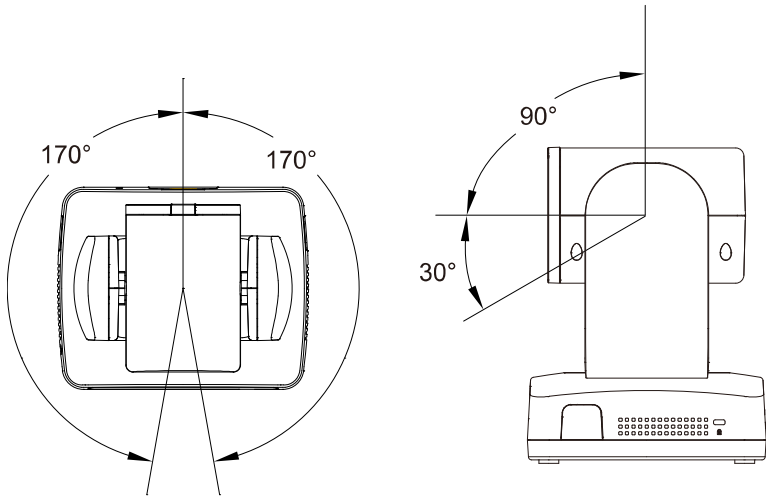

# Remote Control

Your device may come with one of the following remote controls.

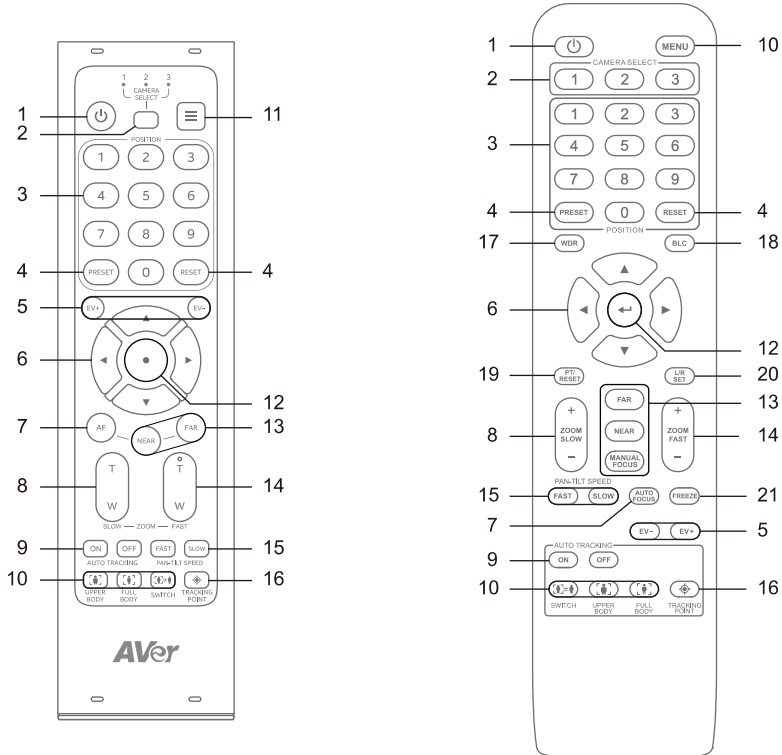

Name	Function
1. Power	Enter Standby Mode or wake up.
2. Camera Select	No selection is required to operate the camera by default. <ul style="list-style-type: none"> <li>Both camera and remote control have been set to 1 at the factory.</li> <li>To assign a number to the camera, go to <b>System &gt; Camera Selector</b> in the OSD menu.</li> </ul>
3. Number Buttons	Press <b>Number button (0-9)</b> to load defined preset 0-9.
4. Preset/Reset	<ul style="list-style-type: none"> <li>To save a preset, press and hold <b>PRESET</b>, then press a <b>Number button (0-9)</b>.</li> <li>To clear a preset, press and hold <b>RESET</b>, then press a <b>Number button (0-9)</b>.</li> </ul>

5. EV +/-	<ul style="list-style-type: none"> <li>• Press to adjust exposure value.</li> <li>• Press and hold <b>EV+</b> to turn on RTMP.</li> <li>• Press and hold <b>EV-</b> to turn off RTMP.</li> </ul>
6. Pan-Tilt Control	Pan and tilt direction control.
7. AF	Turn on Auto Focus.
8. Zoom Slowly	Zoom in or out slowly.
9. Auto Tracking	Turn Auto Tracking on or off.
10. Frame Presenter	<ul style="list-style-type: none"> <li>• Upper Body: Frame presenter's upper body.</li> <li>• Full Body: Frame presenter's full body.</li> <li>• Switch: Switch presenter.</li> </ul>
11. Menu	Open or close the OSD menu during HDMI output.
12. Enter	<ul style="list-style-type: none"> <li>• Confirm a selection in the OSD menu.</li> <li>• Press to One Push Focus (auto focus once).</li> <li>• Press and hold to Framing (frame entire group on screen) once. Framing must be turned on in the OSD menu first, go to <b>Advanced Settings &gt; Framing &gt; Manual</b>.</li> </ul>
13. Near / Far / Manual Focus	Press <b>NEAR</b> or <b>FAR</b> to adjust focus manually. Or press <b>MANUAL FOCUS</b> , if available, to turn on Manual Focus first, then press <b>NEAR</b> or <b>FAR</b> to adjust focus manually.
14. Zoom Fast	Zoom in or out fast.
15. Pan-Tilt Speed	Adjust pan-tilt speed.
16. Tracking Point	Load tracking point (Preset 1).
17. WDR	Turn Wide Dynamic Range on or off.
18. BLC	Turn Backlight Compensation on or off.
19. PT Reset	Reset the pan-tilt position to the center.
20. L/R Set	<ul style="list-style-type: none"> <li>• To invert L/R pan direction, press and hold <b>L/R SET</b>, then press <b>Number button 2</b>.</li> <li>• To reset L/R pan direction, press and hold <b>L/R SET</b>, then press <b>Number button 1</b>.</li> </ul>
21. Freeze	Freeze or unfreeze the live view.

## Shortcuts

Press	To
6 six times (666666)	Reset the device to factory default settings.
7 seven times (7777777)	Display the human tracking frame on the HDMI output.
8 eight times (88888888)	Set the network setting to static IP 192.168.1.168.
9 nine times (999999999)	Clear the web interface login. You'll be prompted to change the username and password on your next login.

# Installation

## Mounting Measurements

- Motion tracking

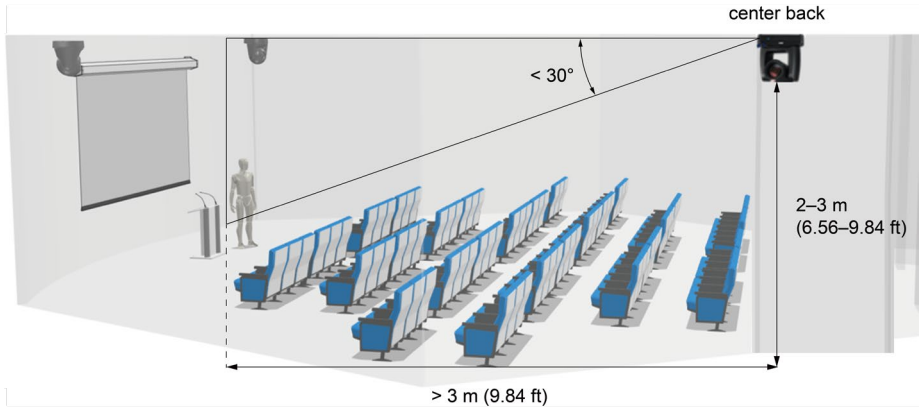

- Voice tracking with third-party microphones

Optical zoom	Distance from subject	Height	Can be inverted
12X	1.6-12 m	1.8-3 m	Yes
21X	2.0-20 m	1.8-3.5 m	Yes
30X	1.8-30 m	1.8-3.8 m	Yes

## Cable Fixing Plate Installation

1. Secure the cable fixing plate to the camera with the included M2 x 4 mm screws (x3).
2. Connect the cables.
3. Use the cable ties to secure the cables to the cable fixing plate.

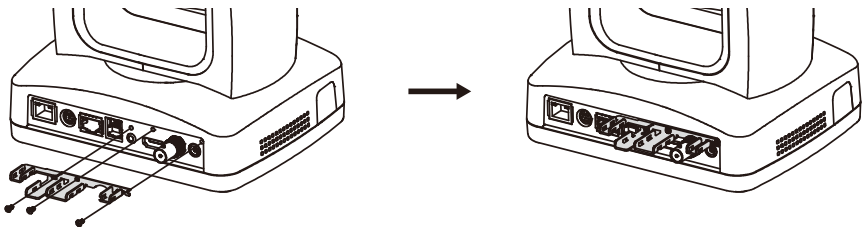

## Ceiling Mount Installation

1. Secure the mount bracket on the ceiling.  
Screw: 4 screws, M4 x 10mm (not Included)
2. Install the mount bracket on the camera.  
Screw: 2 screws, 1/4"-20 L=6.5mm (included)

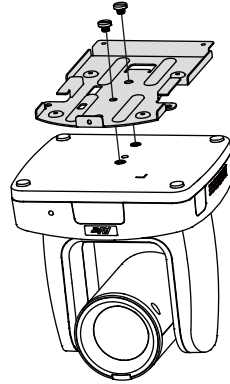
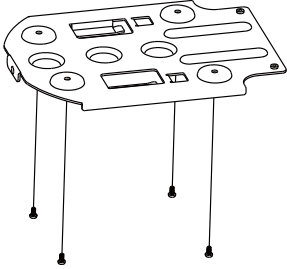

3. Slide the mount bracket with the camera into the mount bracket which secured on the ceiling. And connect the cables.
4. Secure the camera with screws.  
Screw: 3 screws, M3 x 6mm (included)

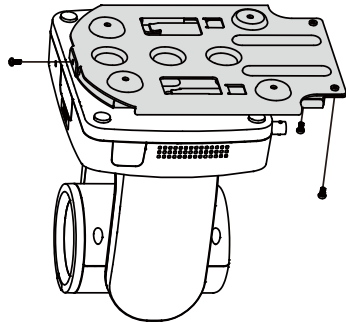
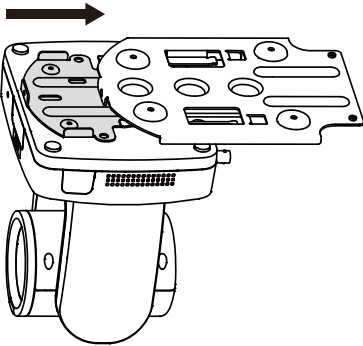

# Connections

## Device Connection

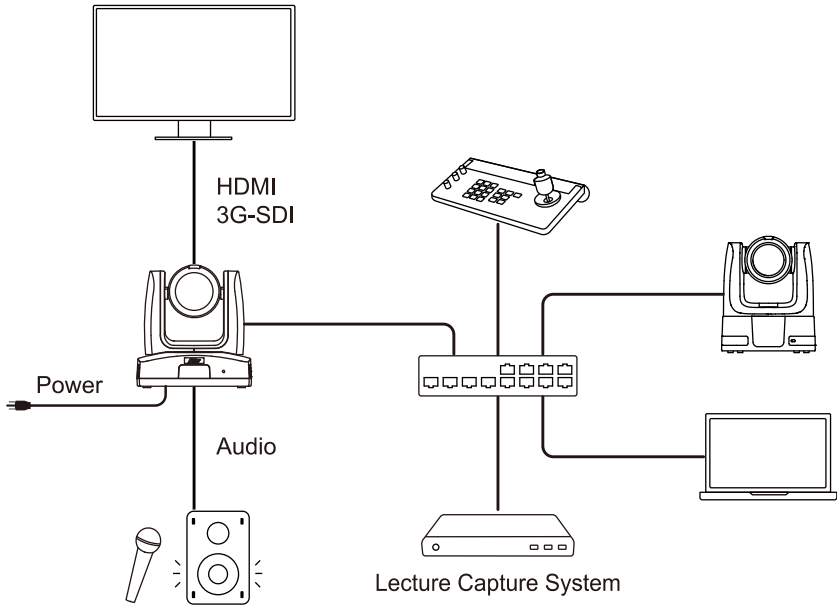

## PoE Connection

Connect the camera PoE++ 802.3at port to the Ethernet switch. The switch must provide PoE++ if you are not using a power adapter.

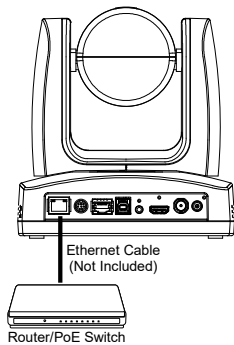

# RS-232 Connection

Connect through the RS-232 for camera control.

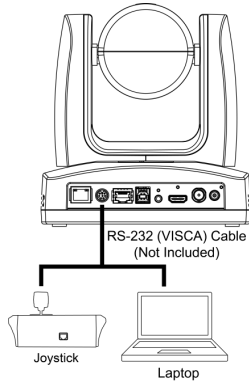

- RS-232 mini DIN9 to mini DIN8 Cable Pin Definition**

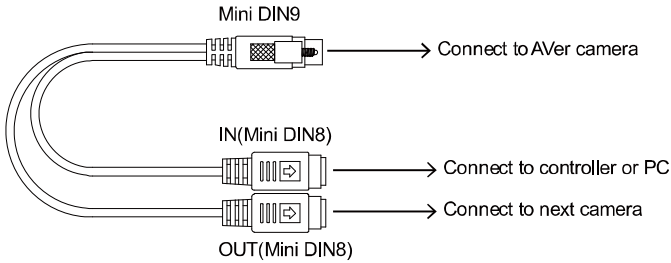

- Mini DIN9 to Mini DIN8 RS-232 Adaptor Cable Pin Definition**

Circuits:

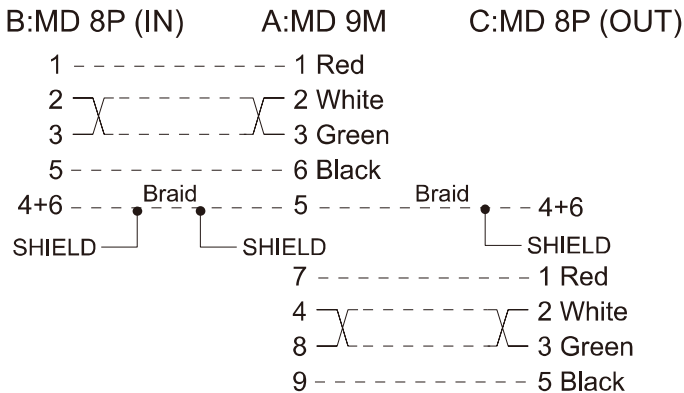

● **S-232 Pin Definition**

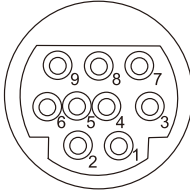

Function	Mini DIN9 Pin #	I/O Type	Signal	Description
VISCA IN	1	Output	DTR	Data Terminal Ready
	2	Input	DSR	Data Set Ready
	3	Output	TXD	Transmit Data
	6	Input	RXD	Receiver Data
VISCA OUT	7	Output	DTR	Data Terminal Ready
	4	Input	DSR	Data Set Ready
	8	Output	TXD	Transmit Data
	9	Input	RXD	Receiver Data
	5	Input	I/O	Detect DIN8/DIN9
---	Shield	---	GND	Ground

● **Mini DIN8 Cable Pin Definition**

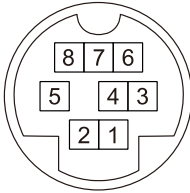

Pin #	Signal
1	DTR
2	DSR
3	TXD
4	GND
5	RXD
6	GND
7	NC
8	NC

● **Din8 to D-Sub9 Cable Pin Definition**

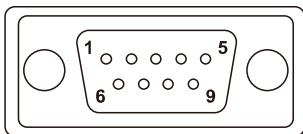

PIN Out:

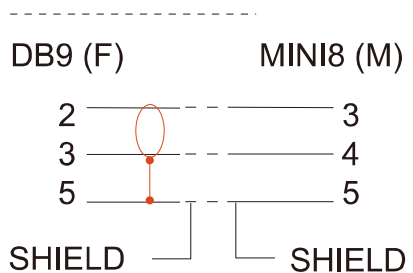

# RS-422 Connection

Use an RS-422 adapter cable to make a RS-422 connection to your control device.

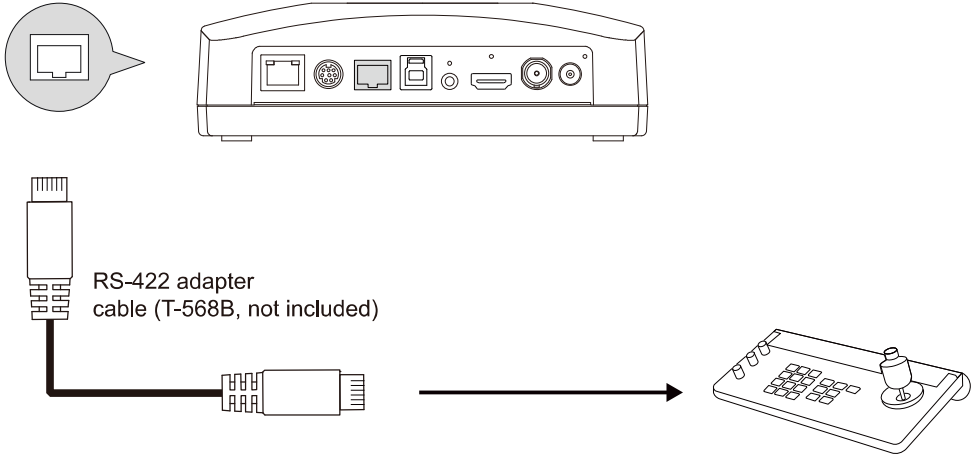

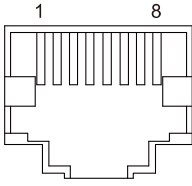

Pin #	Pin
1	TX+
2	TX-
3	RX+
4	TX+
5	TX-
6	RX-
7	RX+
8	RX-

RS-422 Port Pin Definition

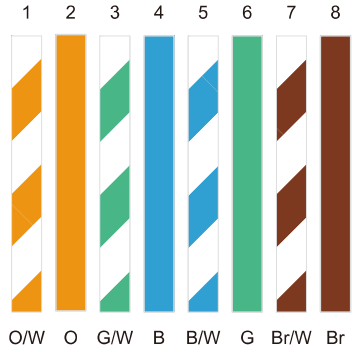

T-568B Cable

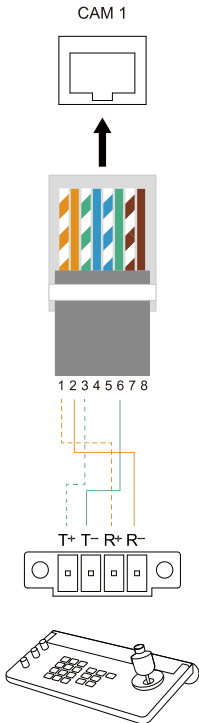

## Audio Input Connection

Connect to your audio devices to receive audio.

Mic input level: 50 mVrms max.; supplied voltage: 2.5 V.

Line input level: 1 Vrms max.

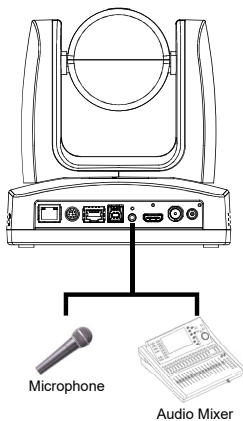

## Video Output Connection

The camera can stream video via HDMI and 3G-SDI simultaneously. Use the included HDMI cable to connect to a monitor or TV. Or use a 3G-SDI cable to connect to a 3G-SDI display.

The OSD menu will appear by default if you make an HDMI connection before turning on the camera.

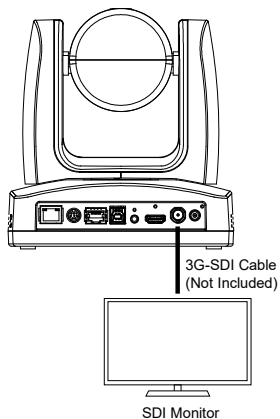
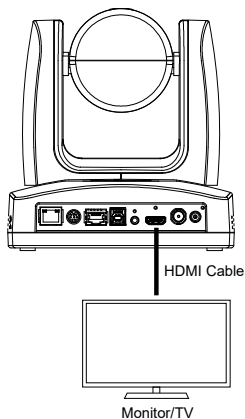

# Get Started

## Power the Device On and Off

The device turns on when you plug it into a power source. The device doesn't have a power button, so you must unplug the power cable to power it off.

## Reset the Device

To reset the device to factory default settings, do any of the following:

OSD menu: Go to **System > Factory Default > On**.

Web interface: Go to **System > Factory Default > Reset to Factory Default**.

## Factory Default Settings

IP address	DHCP
Hostname	[Model name]-[last 6 digits of MAC Address] Find the MAC address on the bottom or rear of the device.
Web interface login	None
Theme Mode	All modes reset to <b>Standard Mode</b> , except <b>Zoom</b> and <b>Teams</b> , which will remain unchanged.

## Access the OSD Menu

During HDMI output, press the **Menu** button  on remote control to open the OSD menu.



## Change Your Network Setting

**Note:** The camera's default network setting is DHCP.

- **Static IP**

1. Press the **MENU** button on remote control to open the OSD menu.
2. Go to **Network > DHCP > Off**.
3. Then go to **Network > Static IP**.  
Select and enter **IP Address**, **Gateway**, **Mask** and **DNS** to configure.

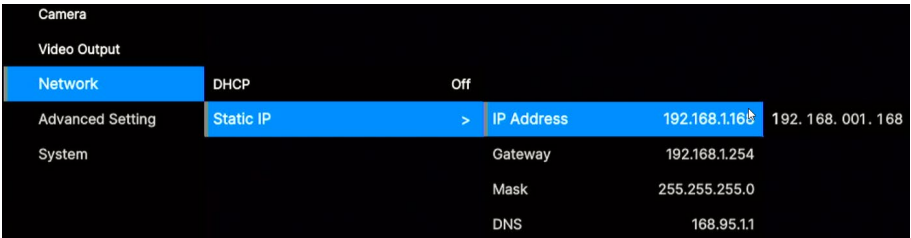

- **DHCP**

1. Press the **MENU** button on remote control to open the OSD menu.
2. Go to **Network > DHCP > On**.

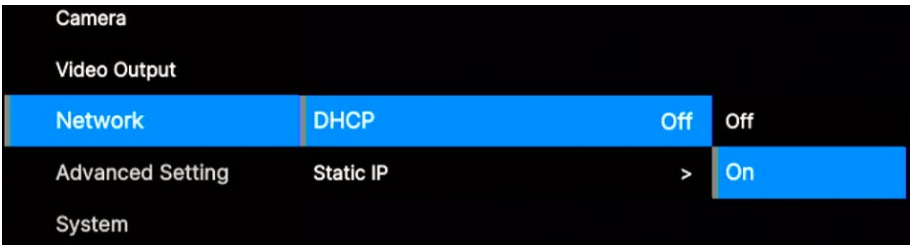

3. Then go to **System > Information** to see your camera's IP address.

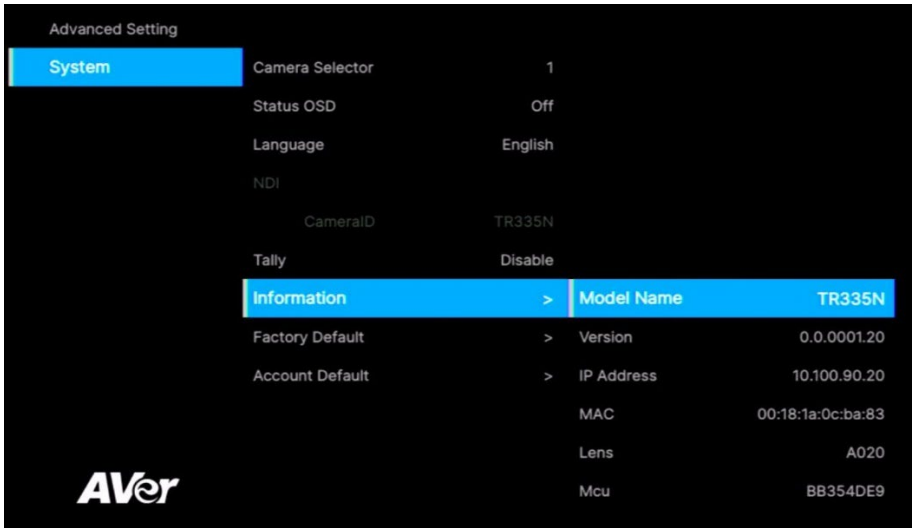

**Note:** If the DHCP server fails to assign an IP address after 30 seconds, the device defaults to 192.168.1.168. Multiple devices will be assigned random IPs within 192.168.1.1 - 192.168.1.254.

To troubleshoot, make sure your DHCP server is running, then disconnect and reconnect the camera LAN cable. Or go to **Network** on the OSD menu > Switch **DHCP** off and on.

## OSD Menu Tree

1 <sup>st</sup> Layer	2 <sup>nd</sup> Layer	3 <sup>rd</sup> Layer	4 <sup>th</sup> Layer
Camera	Exposure Mode	Full Auto	Exposure Value
			Gain Limit Level
			Slow Shutter
		Shutter Priority	Exposure Value
			Shutter Speed
			Gain Limit Level
		Iris Priority	Exposure Value
			Iris Level
			Gain Limit Level
			Slow Shutter
		Manual	Shutter Speed
			Iris Level
	Gain Level		
	Bright	0, 5-31	
	White Balance	Auto	-
		ATW	-
		Indoor	-
		Outdoor	-
		One push	-
		Manual	R Gain (0-255) B Gain (0-255)
	Pan Tilt Zoom	Preset Speed	5/25/50/100/150/200
		Digital Zoom	Off/On
		Digital Zoom Limit	x2-x12
		Pan/Tilt Slow	Off/On
	Noise Reduction	Off/Low/ Medium/High	-
	Saturation	0-10	-
	Contrast	0-4	-
Sharpness	0-3	-	
Mirror	Off/On	-	
Flip	Off/On	-	

	LDC	Off/On	-
Video Output	Theme Mode	Standard, ZOOM, Teams, NDI, Dante, Portrait (beta)	
	Frequency	50Hz/59.94Hz/60Hz	
	Resolution	2160P/30, 2160P/60, 1080P/60, 1080P/30, 1080I/60, 720P/60	
Network	DHCP	Off/On	
	Static IP	IP Address, Gateway, Mask, DNS	
Advanced Setting	Audio	Input Type	Line In/Mic In
		Audio Volume	0-10
	Control	Serial Port	RS-232/RS-422
		Protocol	VISCA/PELCO D/PELCO P
		Camera Address	1-7
		Baud Rate	4800/9600/38400
	Tracking	Off/On	-
	Tracking Mode	Presenter	-
		Zone	-
		Hybrid	-
Framing		-	
System	Camera Selector	1-3	
	Status OSD	Off/On	
	Language	English/繁體中文/日本語	
	NDI	Off/On	
	Tally	Disable/Enable	
	Information	Model Name/Version/IP Address/MAC/Lens/Mcu	
	Factory Default	Off/On	
	Account Default	Off/On	

## Access the Web Interface

To access the web interface of your device, you can use any of the following software to find its IP address:

- AVer Device Utility
- AVer Enterprise Management

**Note:** The default network setting is DHCP

## AVer Device Utility

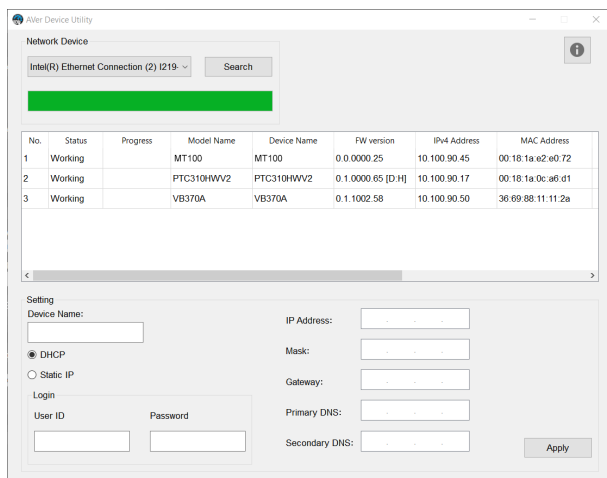

### To access the web interface:

1. Download AVer Device Utility from AVer Download Center (<https://www.aver.com/download-center>) and launch the software.
2. Click **Search** to see available devices on the same local area network (LAN).

#### **Note:**

- Make sure your device is connected to the internet.
- AVer Device Utility and your device must be on the same LAN.

3. Double-click on your device's IP address in the **IPv4 Address** column to open the web interface in your browser.

### To change your network to DHCP or static IP:

1. Select the checkbox of your device.

2. Enter the changed username and password in the **Login** field.
3. Select **DHCP** or **Static IP**, then enter your network settings if applicable in the **Settings** section.
4. Click **Apply**.

## AVer Enterprise Management

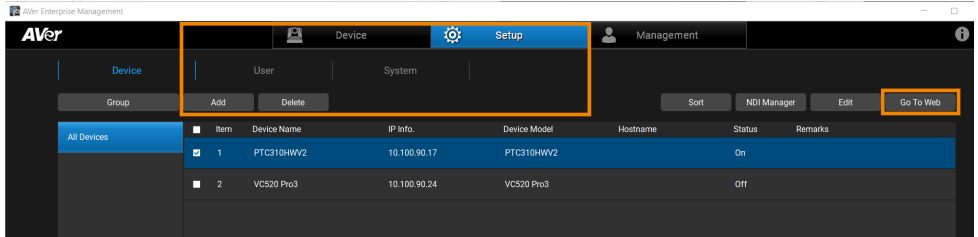

**Note:** The AVer Enterprise Management's default username and password is **admin/admin**.

1. Download AVer Enterprise Management from AVer Download Center (<https://www.aver.com/download-center>) and launch the software.
2. Log in with the AVer Enterprise Management's default username and password **admin/admin**.
3. Go to **Setup > Add**, then click **Auto Search** to see available devices on the same local area network (LAN).
4. Click to select your device, enter the changed username and password, then click **Save** to add the device to the device list.
5. Select the checkbox of your device, then click **Go to Web** button to open the web interface in your browser.

## Log in for the First Time

When you log in for the first time, you'll be prompted to change the username and password. The username and password cannot be the same.

- Username: Use 1-32 characters.
- Password: Use 8-32 characters and a combination of uppercase letters, lowercase letters, and numbers. Symbols (!\$%'()\*+,-./<=>?@[^\_{}~) are optional.

# Web Interface

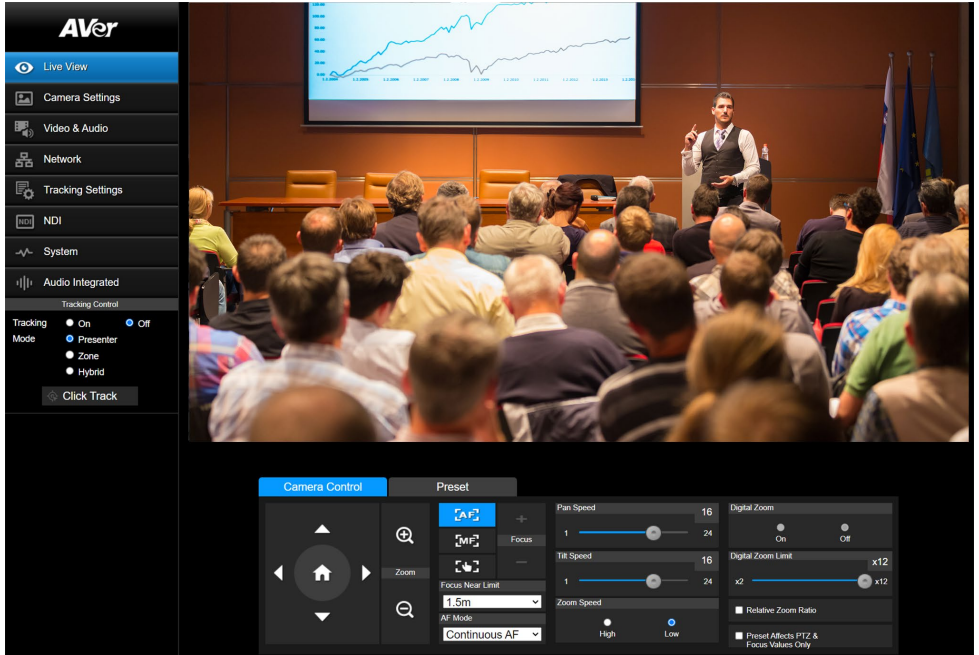

## Live View

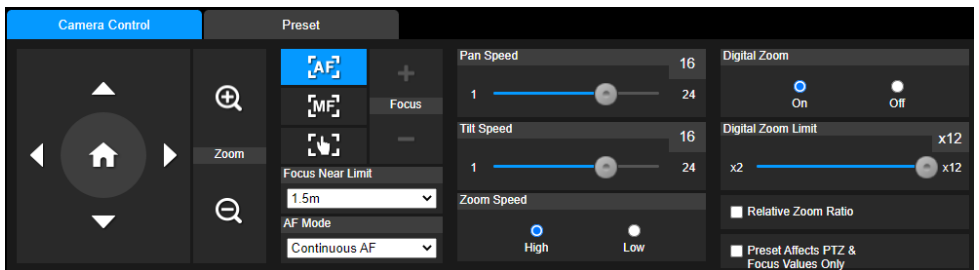

## Camera Control



Item	Description
Pan, Tilt, Zoom Controls	Use pan, tilt, and zoom controls to position the camera.
Home	Reset the pan-tilt position to the center.
Auto Focus 	Focus automatically with an autofocus mode:

AF Mode	<ul style="list-style-type: none"> <li>• AF Trigger after PTZ: Automatically focus after each pan, tilt or zoom.</li> <li>• Continuous AF: Automatically focus continuously.</li> </ul>
Manual Focus 	Focus manually with + - buttons.
One Push Focus 	Focus automatically once.
Focus Near Limit	Select the nearest focus limit.
Pan Speed	Adjust pan, tilt and zoom speed.
Tilt Speed	
Zoom Speed	
Digital Zoom	Turn digital zoom on or off.
Digital Zoom Limit	Select the digital zoom limit.
Relative Zoom Ratio	Select to automatically adjust pan and tilt speeds based on the zoom ratio.
Preset Affects PTZ & Focus Values Only	<p>A preset typically includes pan, tilt, zoom, focus, and 3A (autofocus, auto exposure, auto white balance) values.</p> <p>Select to save only pan, tilt, zoom and focus values for presets.</p>

## Preset

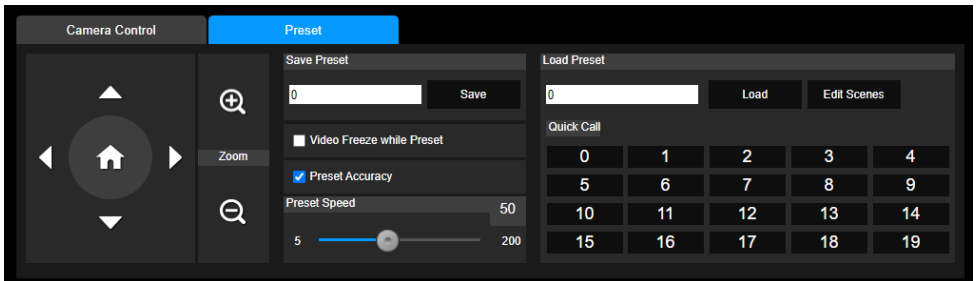

Item	Description
Save Preset	<ol style="list-style-type: none"> <li>1. Position the camera using pan, tilt and zoom controls.</li> <li>2. Enter a preset number (0–255) in the <b>Save Preset</b> field and click <b>Save</b>.</li> </ol>
Load Preset	<ol style="list-style-type: none"> <li>1. Enter a preset number (0–255) in the <b>Load Preset</b> field and click <b>Load</b>.</li> <li>2. Or click a preset number (0–19) in the <b>Quick Call</b> section.</li> </ol>
Video Freeze while Preset	Select to display only the live view from presets. The live view from the moving path will not be displayed.
Preset Accuracy	Select to improve the accuracy of moving to presets.
Preset Speed	Adjust the camera speed when moving to presets.

## Edit Scenes

To customize camera functions for preset 0–9:

1. Click **Edit Scenes**.
2. Select **Scenes 0–9** from the **Scenes List** to add up to 10 CGI commands.
3. Select a scene from the **Set Scenes** drop-down list for each preset.

# Camera Settings



## Exposure

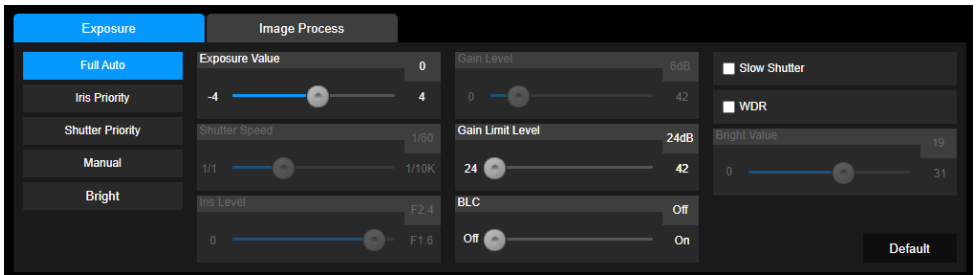

Item	Description
Exposure Mode	<p>Select an exposure mode to adjust image brightness:</p> <ul style="list-style-type: none"> <li>● Full Auto: Automatically adjusts shutter speed (ISO), iris (aperture), and gain for optimal brightness in most environments.</li> <li>● Iris Priority: You set the iris, and the camera adjusts shutter speed and gain. Useful for controlling depth of field.</li> </ul>

	<ul style="list-style-type: none"> <li>● Shutter Priority: You set the shutter speed, and the camera adjusts iris and gain. Ideal for capturing motion with minimal blur.</li> <li>● Manual: Manually adjust shutter speed, iris, and gain.</li> <li>● Bright: Drag the bright value slider to manually increase brightness by adjusting iris and gain.</li> </ul>
Exposure Value	Fine-tunes overall image brightness.
Gain Limit Level	Sets the maximum gain the camera is allowed to use automatically. Helps balance between brightness and image noise.
BLC (Backlight Compensation)	Brightens subjects in front of bright backgrounds (like windows).
Slow Shutter	Makes the image brighter in low light by slowing down shutter speed. May cause motion blur.
WDR (Wide Dynamic Range)	Enhances visibility in scenes with both very bright and very dark areas so details aren't lost in shadows or highlights.
Default	Reset Exposure to factory default settings.

## Image Process

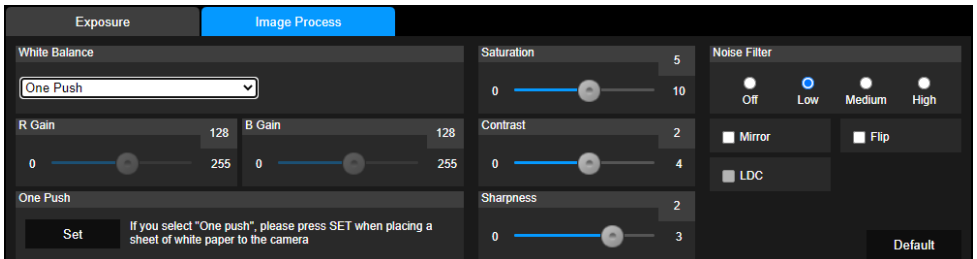

Item	Description
White Balance	<p>Select a white balance mode to match the lighting conditions and ensure accurate color:</p> <ul style="list-style-type: none"> <li>● AWB (Auto White Balance): Automatically adjusts white balance based on the current lighting. Best for stable indoor lighting.</li> <li>● ATW (Auto Tracking White Balance): Continuously adapts to changing lighting conditions. Ideal for dynamic or mixed lighting environments.</li> <li>● Indoor: Fixes red and blue gain for a color temperature of 3200 K.</li> <li>● Outdoor: Fixes red and blue gain for a color temperature of 5800 K.</li> </ul>

	<ul style="list-style-type: none"> <li>• One Push: Calibrates white balance using a white reference. Place a white sheet of paper in front of the lens and click <b>Set</b> to capture accurate color balance based on the current lighting.</li> <li>• Manual: Manually adjust the red and blue gain.</li> </ul>
Saturation	Adjust saturation, contrast and sharpness.
Contrast	
Sharpness	
Noise Filter	Select a noise filtering level.
Mirror	Flip the image horizontally.
Flip	Flip the image vertically.
LDC (30X optical zoom models only)	Correct lens distortion.
Default	Reset Image Process to factory default settings.

## Image Quality (IQ)

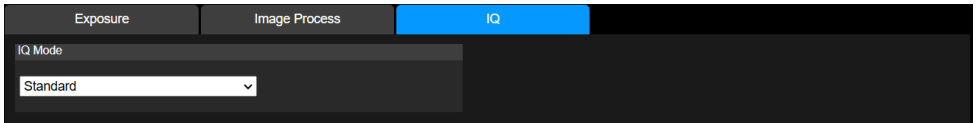

Apply platform-specific image styles—such as Zoom or Teams—without enabling their theme modes, allowing you to achieve the same visual tuning while preserving full output and resolution flexibility.

# Video & Audio

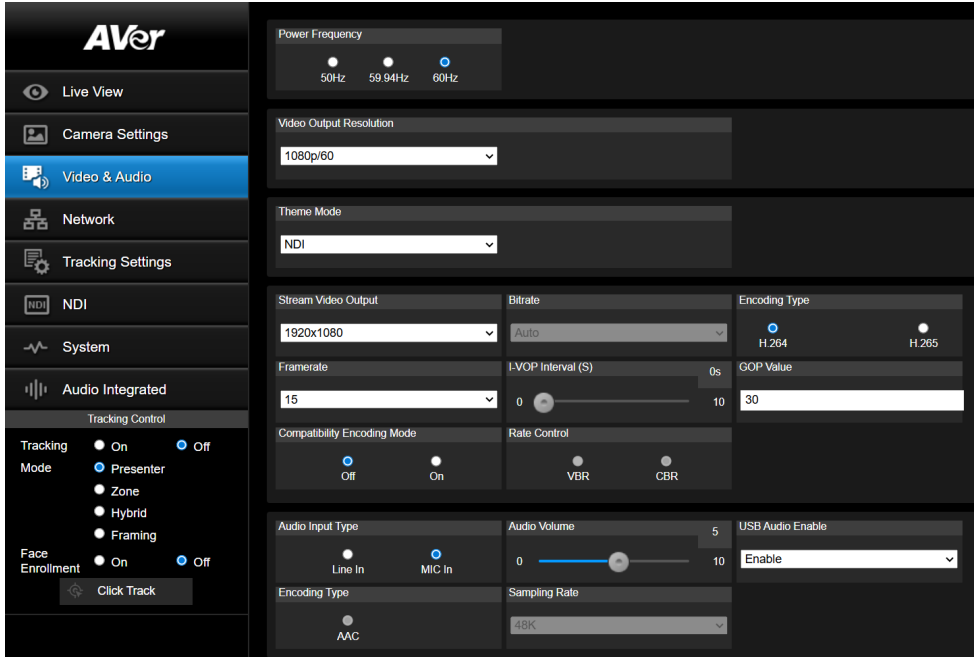

Item	Description
Power Frequency	Select <b>50Hz</b> , <b>59.94Hz</b> or <b>60Hz</b> based on your country and region.
Video Output Resolution	Select a resolution to display on your video output device.
Theme Mode	<p>Select a video mode based on the output interface you want to use.</p> <p><b>Note:</b></p> <ul style="list-style-type: none"> <li>For details on resolution, please refer to <a href="#">&lt;Output Interface Table&gt;</a> °</li> <li>Zoom Mode: USB audio is disabled.</li> <li>Teams Mode: USB audio is disabled. Video is limited to USB output only.</li> </ul> <div data-bbox="408 1305 826 1426" data-label="Image"> </div> <ul style="list-style-type: none"> <li>The <b>Teams app</b> supports only one video feed. Selecting IP,</li> </ul>

	<p>USB, or HDMI mode when using the Teams app sends both PTZ and wide-angle videos, which causes an error.</p> <ul style="list-style-type: none"> <li>When Teams Mode is selected, the camera Live View on the web interface is automatically disabled and cannot be displayed. To view the Live View, switch to another mode.</li> </ul>
Stream Video Output	Select a stream resolution on live view from the drop-down list.
Bitrate	Select a bitrate from the drop-down list.
Encoding Type (video)	Select <b>H.264</b> or <b>H.265</b> to encode streaming video.
Framerate	Select a framerate for live stream – <b>1, 5, 15, 20</b> or <b>30</b> for power frequency <b>59.94Hz</b> or <b>60Hz</b> ; <b>1, 5, 15, 20</b> or <b>25</b> for power frequency <b>50Hz</b> .
I-VOP Interval (S)	<p>Sets how often a keyframe (or I-frame) is inserted in the video stream.</p> <ul style="list-style-type: none"> <li>A keyframe is a full image frame used as a reference point in video. Shorter intervals improve video quality, but increase file size.</li> </ul>
GOP Value (Group of Pictures Value)	<p>Sets the number of frames between two keyframes. This controls how often keyframes are inserted in the video stream.</p> <ul style="list-style-type: none"> <li>When I-VOP Interval = 0, keyframes are inserted based on the GOP Value.</li> <li>When I-VOP Interval &gt; 0, keyframes are inserted based on the set time interval, and GOP Value is ignored.</li> </ul>
Compatibility Encoding Mode	<p>When enabled, the camera uses Multi-Slice encoding to improve compatibility and performance when playing UHD video on certain devices.</p> <p><b>Note:</b> We recommend turning this on only if required for specific decoder compatibility. Otherwise, keep the default setting (Off).</p>
Rate Control	Select <b>VBR</b> or <b>CBR</b> .
Audio Input Type	Select to input audio by <b>Line in</b> or <b>Mic in</b> .
Audio Volume	Drag the slider to set the volume from <b>0</b> to <b>10</b> .
USB Audio Enable	Turn off to stop transmitting audio over USB.
Encoding Type (audio)	AAC
Sampling Rate	48K

## Output Interface Table

Mode	Video Quality	Output Interface	Comment
Standard	Standard	HDMI, SDI, IP, USB, <a href="#">NDI HX2</a>	
Zoom	Zoom certified	HDMI, SDI, IP,	The camera rotates towards the I/O ports (preset

		USB, <a href="#">NDI HX2</a>	20) when not streaming over USB. To change the sleep mode position, go to <b>System</b> > <b>Sleep to Preset</b> on the web interface.
Teams	Teams certified	USB	The camera rotates towards the I/O ports (preset 20) when not streaming over USB. To change the sleep mode position, go to <b>System</b> > <b>Sleep to Preset</b> on the web interface.
NDI	Standard	HDMI, SDI, IP, <a href="#">NDI HX3</a>	
Dante	Standard	Dante	Requires a Dante license. To purchase, please visit the Dante website ( <a href="https://www.getdante.com/">https://www.getdante.com/</a> ).
Portrait (beta)	Standard	HDMI, SDI, IP, USB, <a href="#">NDI HX2</a>	

### Difference between NDI HX2 (Standard Mode) and NDI HX3 (NDI Mode)?

- **NDI HX3** delivers higher quality, lower latency video and audio over HX2. To be certified, HX3 devices need to support low latency, constant bitrate (CBR) encoding, and meet stricter demands such as keyframe response times and a fixed GOP size.
- **NDI HX2** devices follow a more relaxed set of requirements. These devices may have slower latency or keyframe or a larger GOP.

**Note:** For detailed technical requirements, please refer to the NDI documentation (<https://docs.ndi.video/all/developing-with-ndi/ndi-certified/certification-guidelines/technical-requirements>).

# Network

## AVer

- Live View
- Camera Settings
- Video & Audio
- Network**
- Tracking Settings
- NDI
- System
- Audio Integrated

Tracking Control

Tracking Mode:  On  Off

Presenter  Zone  Hybrid

[Click Track](#)

### DHCP

On  Off

IP Address: 192.168.105.110  
Subnet Mask: 255.255.255.0  
Gateway: 10.100.105.254  
DNS: 10.100.1.5

### Hostname

TR315N

### NTP

On  Off

NTP Server: pool.ntp.org

[Confirm](#)

### RTMP Settings

Server URL: \_\_\_\_\_  
Stream Key: \_\_\_\_\_

[Start Stream](#) [STOP](#)

### RTSP Security

On  Off

RTSP Audio Enable:  On  Off

### HLS Settings

Stream URL: \_\_\_\_\_

[Start Stream](#) [STOP](#)

### SRT Settings

Destination IP: 192.168.31.166 Port: 5000 Encryption: None  
Latency: 1000 ms Passphrase: \_\_\_\_\_

Connect Status: Disconnected

[Start Stream](#) [STOP](#)

### HTTPS

Only  On  Off

Upload Certificate: [Choose File](#) No file chosen [Upload](#)

Cert Status: None

SSH:  On  Off

### Visca Port Mode

Default

### Visca Port Number

Port: 2301 [Save](#)

### 802.1X Enable

On  Off

### Eap Method

MD5  TLS  PEAP

### Eap Setting

Identity: \_\_\_\_\_ Password: \_\_\_\_\_

### Client Certificate

[Choose File](#) No file chosen [Upload](#) Private Key Password: \_\_\_\_\_

### CA Certificate

[Choose File](#) No file chosen [Upload](#) [Confirm](#)

### FreeD

On  Off

### Camera ID

235

IP Address: 192.168.1.105 Port: 8000

Plan Backlash: \_\_\_\_\_ Tit Backlash: \_\_\_\_\_

[Confirm](#)

Item	Description
DHCP	Set up the network to DHCP or Static IP. <ul style="list-style-type: none"> <li>• <b>DHCP</b>: Select <b>On</b> to assign the related IP settings with the camera automatically. Click <b>Confirm</b> to save the settings.</li> <li>• <b>Static IP</b>: Select <b>Off</b> to manually enter the <b>IP Address</b>, <b>Netmask</b>, <b>Gateway</b> and <b>DNS</b>. Click <b>Confirm</b> to save the settings.</li> </ul>
Hostname	Enter a hostname that is displayed on devices such as an IP router. <ul style="list-style-type: none"> <li>• The default hostname is [Model name]-[last 6 digits of MAC Address].</li> </ul>
NTP	Turn Network Time Protocol (NTP) on or off.
RTMP Settings	Stream camera live video to a video platform such as YouTube. <ol style="list-style-type: none"> <li>1. Enter the <b>Server URL</b> and <b>Stream Key</b> of the platform. Please refer to the instruction of the platform you use to obtain the server URL and stream key.</li> <li>2. Click <b>Start Stream</b> to start streaming, <b>Stop</b> to stop streaming.</li> </ol>
RTSP Security	Protect your video stream on media players such as VLC, PotPlayer and QuickTime by ensuring that only authorized users can access it. <ul style="list-style-type: none"> <li>• When <b>Security</b> is turned off:               <ol style="list-style-type: none"> <li>1. Enter your camera's RTSP URL into the media player.</li> <li>2. RTSP URL: rtsp://[camera IP address]/live_st1 Example: rtsp://192.168.1.100/live_st1</li> </ol> </li> <li>• When <b>Security</b> is turned on:               <ol style="list-style-type: none"> <li>1. Enter your camera's RTSP URL, username and password into the media player.</li> <li>2. RTSP URL: rtsp://[username:password]@[camera IP address]/live_st1 Example: rtsp://1:1@192.168.1.100/live_st1</li> <li>3. Username and password: camera's web interface login.</li> </ol> </li> </ul>
HLS Settings	Configure HTTP Live Streaming (HLS) settings to provide adaptive bitrate streaming, which ensures smooth playback and minimizes buffering. <ol style="list-style-type: none"> <li>1. Enter the stream URL obtained from the streaming service or server.</li> <li>2. Click <b>Start Stream</b> to start streaming, <b>Stop</b> to stop streaming.</li> </ol>
SRT Settings	<ul style="list-style-type: none"> <li>• vMix               <ol style="list-style-type: none"> <li>1. Make sure the vMix workstation and your camera are on same network. Copy the workstation's IP address.</li> </ol> </li> </ul>

```

C:\WINDOWS\system32\cmd.exe
Windows IP Configuration

Wireless LAN adapter Local Area Connection* 1:

Media State . . . . . : Media disconnected
Connection-specific DNS Suffix  . :

Ethernet adapter Ethernet:

Connection-specific DNS Suffix  . :
Link-local IPv6 Address . . . . . : fe80::8013:bd79:8b8c:2339%21
IPv4 Address. . . . . : 192.168.1.10
Subnet Mask . . . . . : 255.255.255.0
Default Gateway . . . . . :

Wireless LAN adapter Wi-Fi:

Connection-specific DNS Suffix  . : aver.com
Link-local IPv6 Address . . . . . : fe80::685d:c927:1f05:a46e%11
IPv4 Address. . . . . : 10.100.200.67
Subnet Mask . . . . . : 255.255.255.0
Default Gateway . . . . . : 10.100.200.254

Ethernet adapter Bluetooth Network Connection:

```

- Go to **Stream** tab > select **SRT (Listener)** from the **Stream Type** drop-down list. Copy the **Port** value.

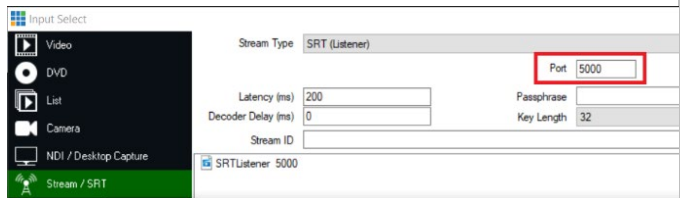

- Paste the IP address and Port value into **SRT Settings** fields and click **Start Stream**. **Connect Status** will change to **Connected**.

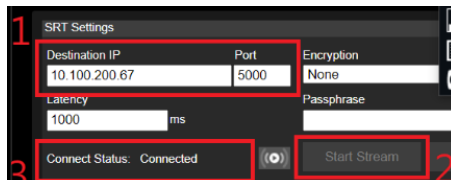

- OBS (Open Broadcaster Software)
    - Make sure the OBS workstation and your camera are on same network. Copy the workstation's IP address.

```

Connection-specific DNS Suffix . . : aver.com
Link-local IPv6 Address . . . . . : fe80::fldc:bcda:87bd:ac1
IPv4 Address. . . . . : 10.100.105.127
Subnet Mask . . . . . : 255.255.255.0
Default Gateway . . . . . : 10.100.105.254

```

- Open OBS. Add a scene and a source.
- Enter "srt://[Workstation IP]:[port]?mode=listener" in the **Input** field.  
Example: srt://10.100.105.127:8889?mode=listener

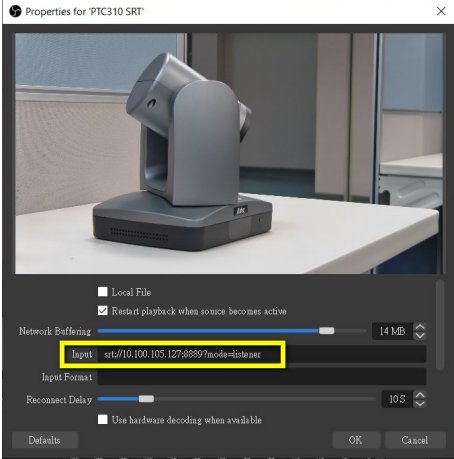
	 <p>4. If there is no image, right-click on the source &gt; <b>Transform</b> &gt; <b>Fit to screen</b> to re-scale image.</p>
HTTPS	<p>Enable HTTPS to establish a secure connection between your browser and your camera. To enable HTTPS access on your camera:</p> <ol style="list-style-type: none"> <li>1. Obtain a SSL certificate for encryption and decryption in base-64 encoded format and use a private key in PKCS#8 format (unencrypted).</li> <li>2. Package the required certificate content into PEM format. The SSL certificate uploaded to the camera must be in PEM format.</li> <li>3. Click <b>Choose File</b> to select the certificate file, and then click <b>Upload</b>.</li> <li>4. Turn on HTTPS.</li> </ol>
SSHD	<p>Turn remote debugging from AVer on or off.</p>
VISCA Port Mode	<p>Select a VISCA port mode, then enter the <b>VISCA Port Number</b>.</p>
802.1x Enable	<p>Turn 802.1x Enable on or off.</p>
Eap Method	<p>When <b>802.1x Enable</b> is turned on, select an Eap method.</p>
Eap Setting	<p>Based on your Eap method, complete the authentication and click <b>Confirm</b>.</p>
FreeD	<p>Turn the FreeD protocol on to send camera positioning data to a virtual reality production system.</p> <p>When FreeD is turned on, enter the following information:</p> <ul style="list-style-type: none"> <li>• Your <b>Camera ID</b>.</li> <li>• The <b>IP Address</b> and <b>Port</b> of the device receiving your camera's positioning data.</li> <li>• Manually enter pan and tilt backlash amount to ensure accurate aiming.</li> </ul>

# Tracking Settings

For details on tracking settings, please refer to their respective chapters.

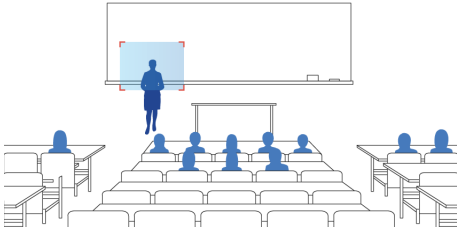

## Presenter

Frames and follows the presenter on screen.

---

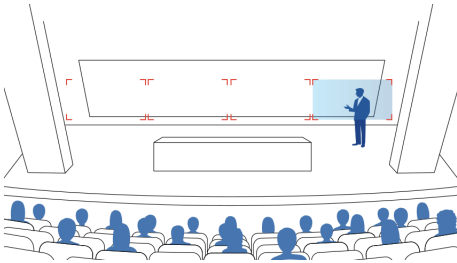

## Zone

Frames and follows the presenter on screen using up to four presets. When the presenter exits the previous preset, the camera will follow and move to the next preset.

---

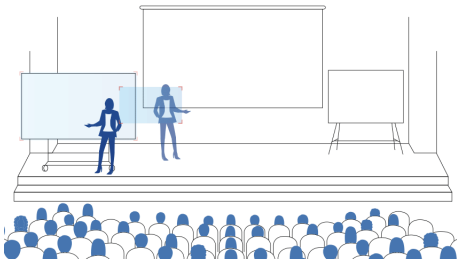

## Hybrid Mode

Hybrid Mode combines Presenter Mode and Zone Mode.

Uses presets when the presenter is inside of presets, frames and follows the presenter when they are outside of presets.

## Framing

Auto Framing frames entire group on screen automatically while Manual Framing frames entire group on screen once.

## Compare Tracking Modes

Tracking Mode	Tracking Point	Available presets	Click Track	Face Enrollment
<b>Presenter</b>	Preset 1	–	✓	✓
<b>Zone</b>	Preset 6	Presets 6–9	–	–
<b>Hybrid</b>	Preset 1	Presets 10–13	✓	✓
<b>Framing</b>	Preset 0	–	–	–

## Tracking Control Panel

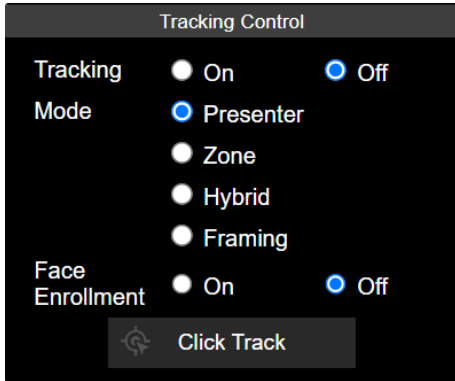

- **Tracking:** Turn tracking on or off.
- **Mode:** Select a tracking mode to frame and follow the presenter. For details on tracking settings, please refer to respective chapters.
- **Click Track:** Switch the presenter you want to track. Click **Click Track** to frame everyone on screen in bounding boxes and click to select the presenter you want to track. Selected presenter will be in a red frame.



- **Face Enrollment:** Build a facial library for any environment where multiple presenters rotate through the same space. Please refer to [Face Enrollment](#) for settings.

# Presenter Mode

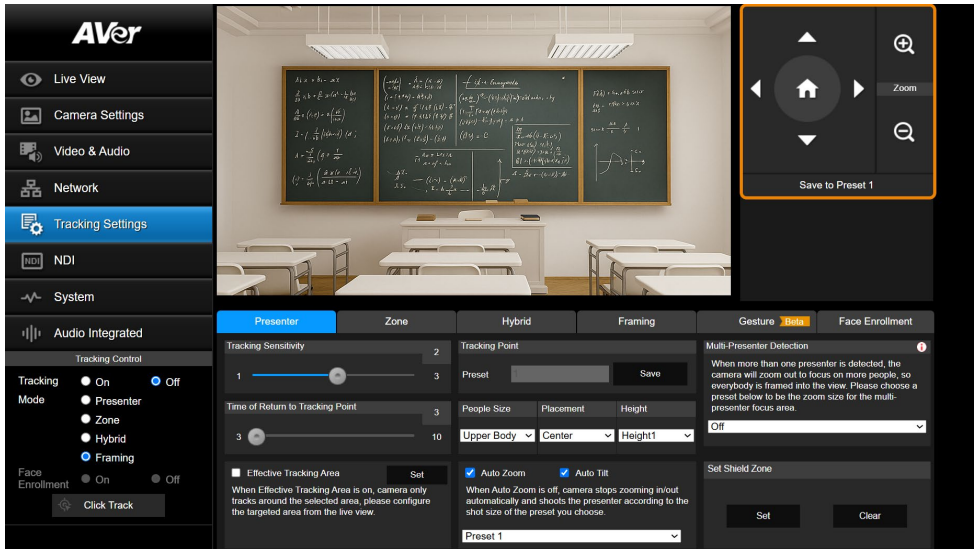

Presenter Mode frames and follows the presenter on screen, and returns to the tracking point (Preset 1) when no one is on screen.

## To set up Presenter Mode:

1. Go to **Tracking Settings > Presenter**.
2. Use pan, tilt and zoom controls to position your camera and click **Save to Preset 1** to save the Tracking Point.
3. Configure additional settings:

Item	Description
Tracking Sensitivity	Drag the slider to adjust tracking sensitivity.
Time of Return to Tracking Point	Drag the slider to set a delay (second) before the camera return to the tracking point.
Effective Tracking Area	Define an effective tracking area. The camera only tracks the presenter inside that area. <ol style="list-style-type: none"> <li>1. Select the checkbox and click <b>Set</b>.</li> <li>2. Drag the five handles of the red pentagon to adjust the size of the tracking area.</li> </ol>
Tracking Point	If no one is on screen, the camera returns to the tracking point (Preset 1).

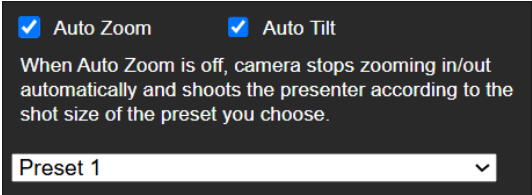
<p>People Size, Placement, Height</p>	<ul style="list-style-type: none"> <li>• Frame the presenter's full body or upper body.</li> <li>• Horizontally align the presenter to the left, center or right.</li> <li>• Vertically align the presenter to the center or bottom.</li> </ul>
<p>Auto Zoom</p>	<ul style="list-style-type: none"> <li>• When <b>Auto Zoom</b> is off, the zoom ratio will be based on your selected preset from the drop-down list.</li> <li>• When <b>Auto Tilt</b> is turned off, the tilt angle will be based on your selected preset from the drop-down list.</li> </ul>
<p>Auto Tilt</p>	
<p>Multi-Presenter Detection</p>	<p>When multiple presenters are detected, the camera will go to your selected Multi-Presenter Detection preset and frame entire group on screen.</p> <ol style="list-style-type: none"> <li>1. Go to <b>Tracking Settings &gt; Presenter</b>.</li> <li>2. Make sure <b>Auto Zoom</b> is turned on.</li> <li>3. Select a preset from the <b>Multi-Presenter Detection</b> drop-down list to turn on Multi-Presenter Detection.</li> </ol> <p><b>Note:</b></p> <ul style="list-style-type: none"> <li>• Make sure you have defined the required preset.</li> <li>• The preset should cover a wide area where multiple presenters may appear.</li> </ul> <ol style="list-style-type: none"> <li>4. You can also define an exclusion zone in <b>Set Shield Zone</b> to avoid unwanted multi-presenter detection, such as when you have audience in the front row.</li> </ol>
<p>Set Shield Zone</p>	<p>Define an exclusion zone to avoid unwanted multi-presenter detection.</p> <ul style="list-style-type: none"> <li>• To add a shield zone: <ol style="list-style-type: none"> <li>1. Click <b>Set</b>.</li> <li>2. Drag a gray square over an area you want to shield on the live view with your mouse.</li> <li>3. Click <b>Save</b>.</li> </ol> </li> </ul>

- To clear a shield zone:
  1. Click **Set**.
  2. Click **Clear** to clear a shield zone on the live view.
  3. Click **Save**.

4. Turn on **Tracking** and select **Presenter Mode** on the tracking control panel.

**Note:** Presenter Mode lets you switch the presenter you want to track. Click the **Click Track** button to frame everyone on screen in bounding boxes and click to select the presenter you want to track. Selected presenter will be in a red frame.



**To set up Presenter Mode with the remote control:**

1. Use directional buttons to position your camera. Press and hold **Preset**, then press **Number button 1** to save the tracking point (Preset 1).
2. Press **Auto Tracking ON** to turn on Presenter Mode.
3. Press **Upper Body** or **Full body**.
4. To switch presenters, press **Switch**. With each press, cycle through presenters clockwise, starting from the center.

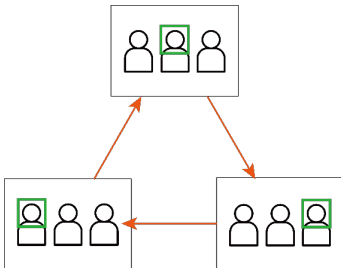

## Zone Mode

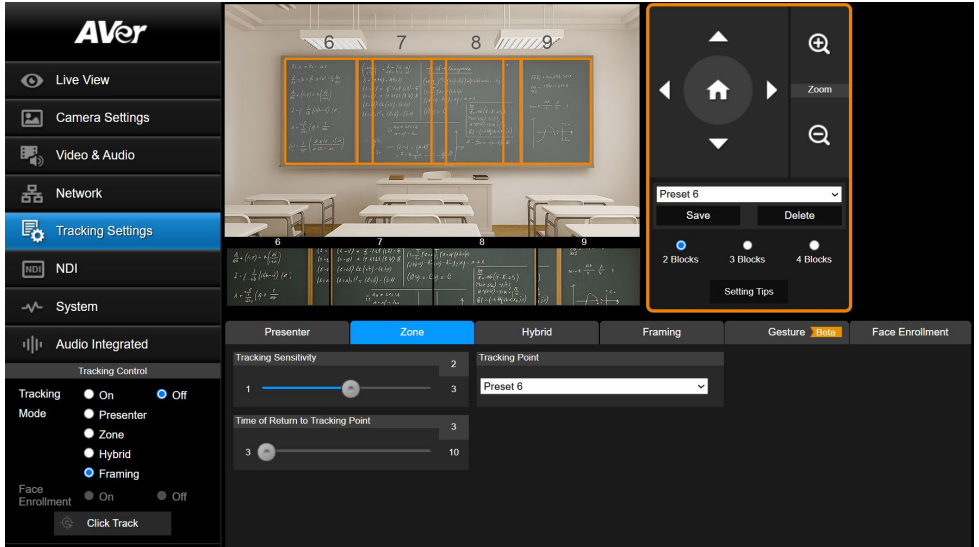

Zone Mode uses up to 4 presets to frame and follow the presenter on screen. When the presenter exits the previous preset, the camera will follow and move to the next preset.

When no one is in the presets, the camera returns to the tracking point (Preset 6 or selected preset).

**Note:** Zone Settings Mode detects faces or human silhouettes entering the presets. Beside the presenter, make sure there are no other faces or human silhouettes on a poster in the presets to avoid interference.

### To set up Zone Mode:

1. Go to **Tracking Settings > Zone**.
2. Select the number of **Blocks** (presets) you want to track.
3. Select the presets you want to save from the drop-down list. Presets 6–9 are available.

2 Blocks	3 Blocks	4 Blocks
Preset 6、7	Preset 6、7、8	Preset 6、7、8、9

- Use pan, tilt and zoom controls to position your camera and click **Save** to save that position. A thumbnail will appear in the preview. Repeat these steps for all presets.

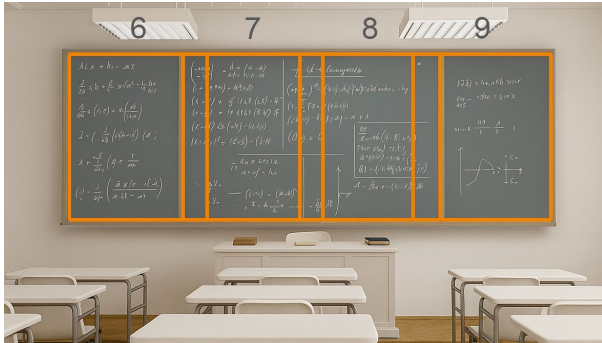

**Note:** Define overlapping presets for a smooth transition. When the presenter exits the previous preset, the camera will follow and move to the next preset.

- Configure additional settings:

Item	Description
Tracking Sensitivity	Drag the slider to adjust tracking sensitivity.
Time of Return to Tracking Point	Drag the slider to set a delay (second) before the camera return to the tracking point.
Tracking Point	<p>If no one is in the presets, the camera returns to the tracking point (Preset 6 or selected preset).</p> <div style="border: 1px solid black; background-color: #333; color: white; padding: 5px;"> <p>Tracking Point</p> <p>Preset 6 <span style="float: right;">▼</span></p> </div>

- Turn on **Tracking** and select **Zone Mode** on the tracking control panel.



### To set up Zone Mode with the remote control:

#### To set up Zone Mode with the remote control:

1. Use directional buttons to position your camera. Press and hold **Preset**, then press **Number button 6** to save Preset 6. Repeat these steps for Preset 7.

**Note:** Zone Mode has 2 blocks by default. To select more blocks, access the web interface.

2. Press **Auto Tracking ON** to turn on Presenter Mode
3. Then press and hold **Tracking Point** to switch tracking mode from Presenter Mode to Zone Mode.

## Hybrid Mode

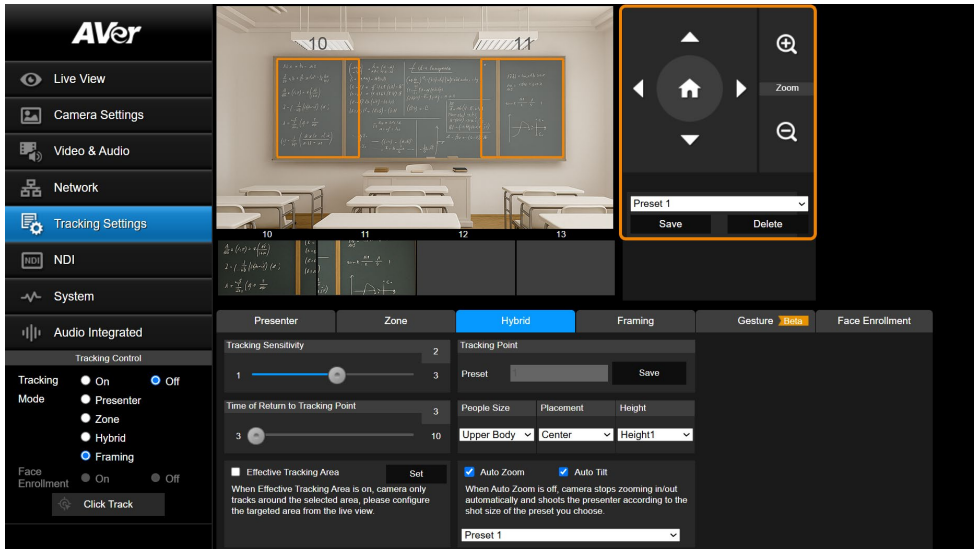

Hybrid Mode combines Presenter Mode and Zone Mode.

Uses presets when the presenter is inside of presets, frames and follows the presenter when they are outside of presets.

When no one is on screen, the camera returns to the tracking point (Preset 1).

### To set up Hybrid Mode:

1. Go to **Tracking Settings > Hybrid**.
2. Use pan, tilt and zoom controls to position your camera and click **Save to Preset 1** to save the **Tracking Point**.
3. Then, select the presets you want to save from the drop-down list. Presets 10–13 are available.

4. Use pan, tilt and zoom controls to position your camera and click **Save** to save that position. A thumbnail will appear in the preview. Repeat these steps for all presets.



**Note:** Do not overlap presets. Leave ample room between presets for a smooth transition.

5. Configure additional settings:

Item	Description
Tracking Sensitivity	Drag the slider to adjust tracking sensitivity.
Time of Return to Tracking Point	Drag the slider to set a delay (second) before the camera returns to the tracking point.
Effective Tracking Area	Define an effective tracking area. The camera only tracks the presenter inside that area. <ol style="list-style-type: none"> <li>1. Select the checkbox and click <b>Set</b>.</li> <li>2. Drag the five handles of the red pentagon to adjust the size of the tracking area.</li> </ol>
Tracking Point	If no one is on screen, the camera returns to the tracking point (Preset 1).
People Size	Frame the presenter's full body or upper body.
Auto Zoom	<ul style="list-style-type: none"> <li>• When <b>Auto Zoom</b> is turned off, the zoom ratio will be based on your selected preset from the drop-down list.</li> <li>• When <b>Auto Tilt</b> is turned off, the tilt angle will be based on your selected preset from the drop-down list.</li> </ul>
Auto Tilt	<div style="background-color: #333; color: white; padding: 10px; border: 1px solid #555;"> <p><input checked="" type="checkbox"/> Auto Zoom      <input checked="" type="checkbox"/> Auto Tilt</p> <p>When Auto Zoom is off, camera stops zooming in/out automatically and shoots the presenter according to the shot size of the preset you choose.</p> <p>Preset 1 <span style="float: right;">▼</span></p> </div>

6. Turn on **Tracking** and select **Hyrbid Mode** on the **Tracking Control** panel.

**Note:** Presenter Mode lets you switch the presenter you want to track. Click the **Click Track** button to frame everyone on screen in bounding boxes and click to select the presenter you want to track. Selected presenter will be in a red frame.

# Framing

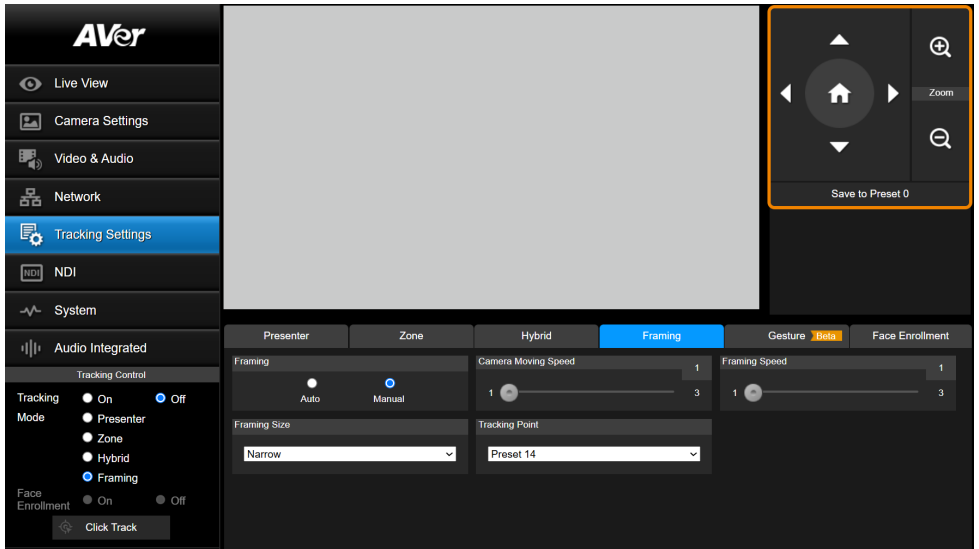

Auto Framing frames entire group on screen automatically while Manual Framing frames entire group on screen once.

When no one is on screen, the camera returns to the pan-tilt center (default) or the Tracking Point (optional, selected preset).

## To set up Framing:

1. Go to **Tracking Settings > Framing**.
2. Configure additional settings:

Item	Description
Framing	Select a framing mode. <ul style="list-style-type: none"> <li>● Auto: Frames entire group on screen automatically.</li> <li>● Manual: Frames entire group on screen once.</li> </ul>
Framing Size	Select a framing size to include or remove excess space on either side of the subject.
Camera Moving Speed	Drag the slider to adjust pan, tilt, and zoom speed: <b>1 = Slow, 3 = Fast</b> .

Tracking Point	<p>When no one is on screen, the camera returns to the pan-tilt center (default) or the Tracking Point (optional, selected preset).</p> <p>To select a Tracking Point, make sure you have defined the required preset.</p> 
Framing Speed	<p>The camera auto frames every time a subject enters or leaves the screen. If Auto Framing feels too frequent, drag the slider to adjust the trigger speed: <b>1 = Slow, 3 = Fast</b>.</p>

3. Select **Framing**, then turn on **Tracking** on the tracking control panel.

**Note:** After Manual Framing once, Framing remains turned on but inactive. To Manual Framing again, press and hold **Enter** on the remote control.

## Gesture (Beta)

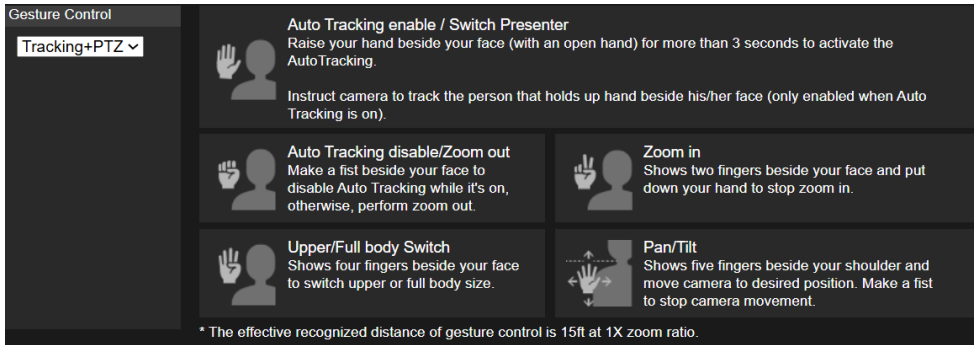

The effective distance is 15 feet at 1X zoom ratio.

When a gesture is recognized, the LED indicator will flash purple.

### To set up gesture control:

Select an option from the **Gesture Control** drop-down list.

- **Off:** Turn off gesture control.
- **Tracking:** Gesture control is available in tracking modes.
- **PTZ:** Gesture control is available in PTZ mode.
- **Tracking + PTZ:** Gesture control is available in all tracking and PTZ modes.

# Face Enrollment

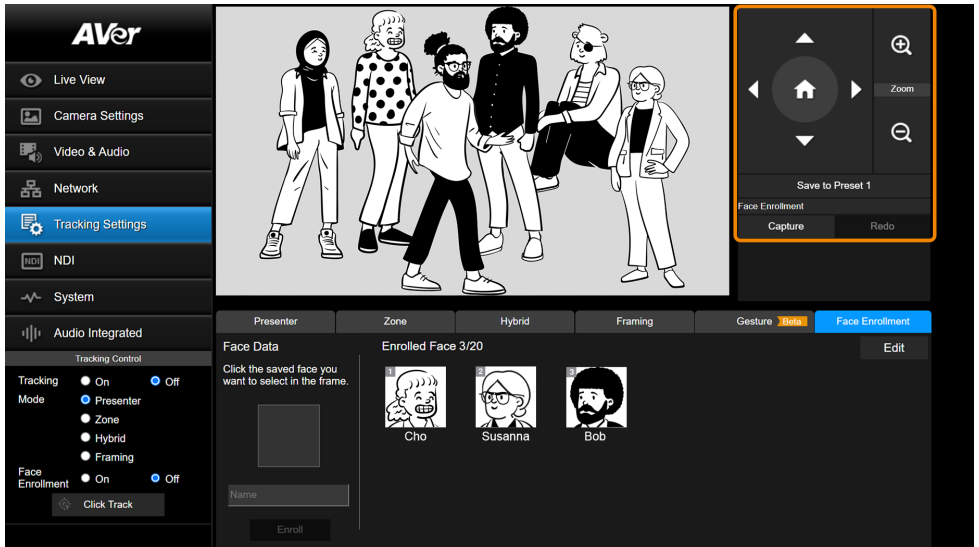

Face Enrollment lets you build a facial library for your classroom, training center, or any environment where multiple presenters rotate through the same space. By enrolling faces ahead of time, the camera can quickly identify presenters and prioritize who to track.

Up to 20 faces can be stored at a time. The number in the top-left corner of the thumbnail indicates the tracking priority.



## To enroll a presenter:

1. Go to **Tracking Settings > Face Enrollment**.
2. Have one or more presenters face the camera. Profiles won't be recognized.
3. Click **Capture** to take a snapshot and frame every face on screen in bounding boxes.

5. Click the face you want to enroll, name it, then click **Enroll** to save. Repeat this step to enroll multiple faces.

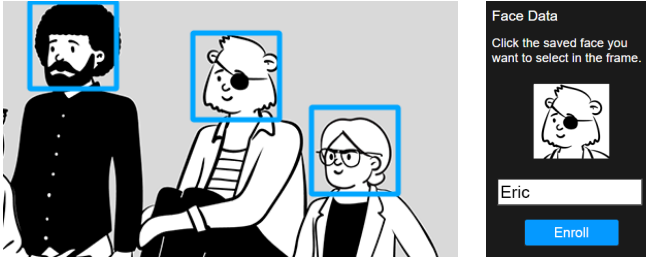

6. You can click **Redo** to take a new snapshot and enroll more faces as needed.

**To rename, delete or prioritize a presenter:**

1. Go to **Tracking Settings > Face Enrollment**.
2. Click **Edit**.
3. You can rename, delete, or change the tracking priority of a presenter by selecting a number from the drop-down list.
4. Click **OK**.

# NDI

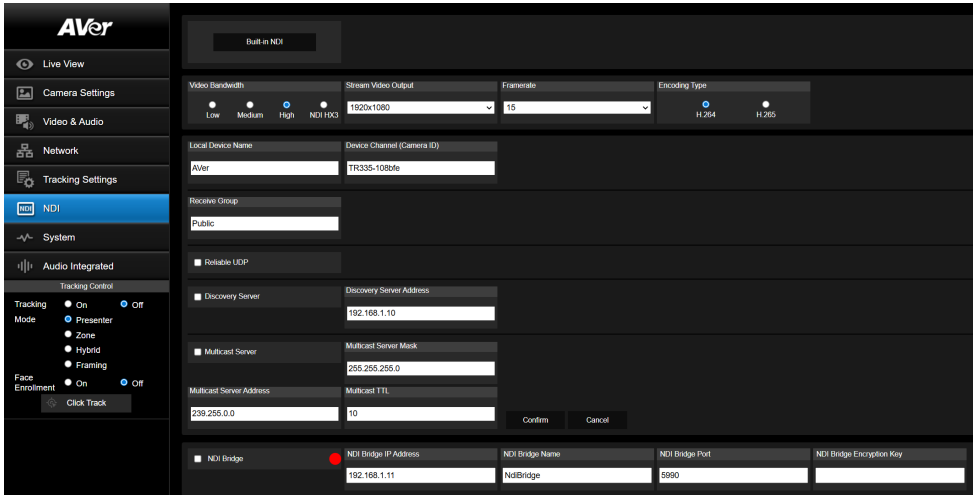

Item	Description									
Built-in NDI	Upgrade to the latest firmware to enable NDI at no additional cost.									
Video Bandwidth	<p>Select a bandwidth.</p> <ul style="list-style-type: none"> <li>In NDI HX3 Mode, framerate adjustment is restricted as per certification guidelines. It is possible with other bandwidths (Low, Medium, High).</li> <li>The main difference between High and NDI HX3 Modes lies in the compression settings.</li> </ul> <table border="1"> <thead> <tr> <th>Parameter</th> <th>High</th> <th>HX3</th> </tr> </thead> <tbody> <tr> <td>Bitrate</td> <td>~64 Mbps</td> <td>~ 90 Mbps</td> </tr> <tr> <td>GOP Value</td> <td>1 second (adjustable when I-VOP Interval = 0)</td> <td>20 frames (non-adjustable)</td> </tr> </tbody> </table>	Parameter	High	HX3	Bitrate	~64 Mbps	~ 90 Mbps	GOP Value	1 second (adjustable when I-VOP Interval = 0)	20 frames (non-adjustable)
Parameter	High	HX3								
Bitrate	~64 Mbps	~ 90 Mbps								
GOP Value	1 second (adjustable when I-VOP Interval = 0)	20 frames (non-adjustable)								
Stream Video Output	Choose a streaming output resolution for the live view.									
Framerate	Choose a framerate.									
Encoding Type	Select <b>H.264</b> or <b>H.265</b> .									
Local Device Name	<p>Enter a name that identifies your camera group on the NDI software.</p> <ul style="list-style-type: none"> <li>The default is AVer.</li> </ul>									

Device Channel (Camera ID)	<p>Enter a name that identifies your camera on the NDI software.</p> <ul style="list-style-type: none"> <li>• The default is your model name.</li> <li>• A name must have no more than 10 characters. Use number, upper and lower case letter, or special character (! @ % ^ , . / : + ? [ ] { } - _ ~).</li> </ul>
Receive Group	<p>Enter a name for a receive group.</p> <ul style="list-style-type: none"> <li>• All devices in the receive group receive the same NDI streams.</li> <li>• The receive group should remain <b>public</b>. If this is changed, you will need to join the group through NDI® Access Manager.</li> </ul>
Reliable UDP	Select the checkbox to enable Reliable User Datagram Protocol (RUDP).
Discovery Server	Select the checkbox to enable discovery server to allow devices to discover and connect to each other on a network automatically.
Discovery Server Address	Enter the IP address of a server running a discovery server application.
Multicast Server	Select the checkbox to enable multicast server to allow efficient distribution of NDI streams to multiple receivers without overwhelming the network.
Multicast Server Mask	Enter the network mask to specify the range of IP addresses that are eligible to receive NDI streams.
Multicast Server Address	Enter the IP address of a group of recipients that receive NDI streams from a multicast server.
Multicast TTL	Enter a multicast time to live (TTL) value between 1-255 to control the distance multicast packets can travel.
NDI Bridge	Connects and shares NDI streams between remote NDI-enabled devices and infrastructures across a wide area networks (WAN). Requires the NDI Tools from NewTek ( <a href="https://ndi.video/tools/">https://ndi.video/tools/</a> ).

# System

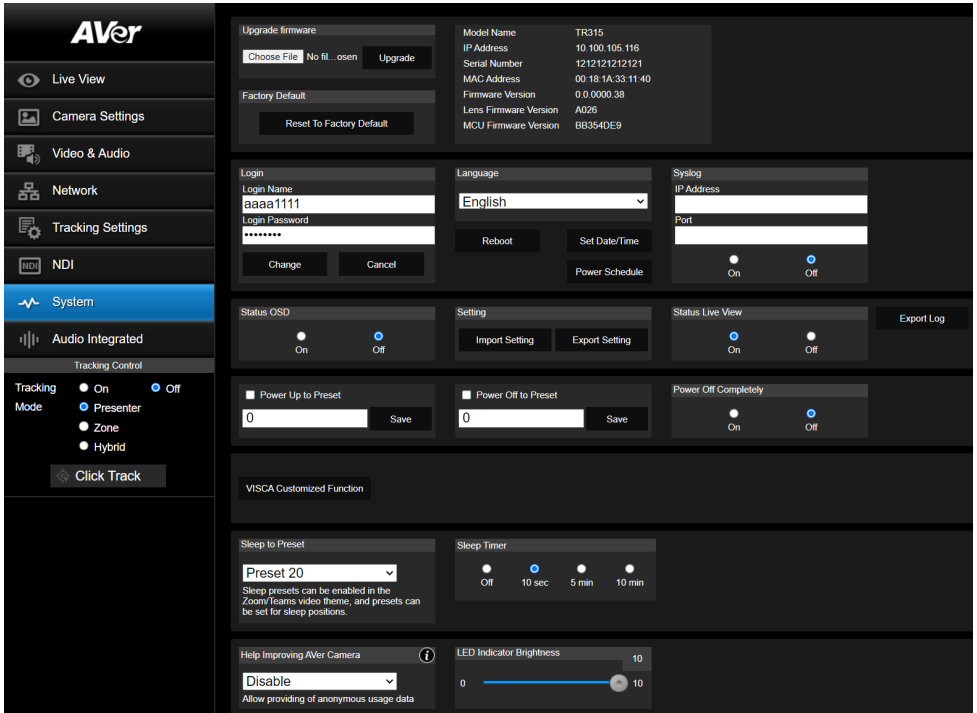

Item	Description
Upgrade Firmware	<p>To upgrade the firmware:</p> <ol style="list-style-type: none"> <li>1. Download the latest firmware from AVer Download Center (<a href="https://www.aver.com/download-center">https://www.aver.com/download-center</a>).</li> <li>2. On the web interface, go to <b>System &gt; Upgrade firmware</b>.</li> <li>3. Click <b>Browse</b> to select the firmware.</li> <li>4. Click <b>Upgrade</b>.</li> <li>5. Refresh the browser after the upgrade is complete.</li> </ol> <p><b>Note:</b> Keep your camera connected to a power source during firmware upgrade. Network connection will be lost during the process and camera will reboot automatically after upgrading.</p>
Factory Default	Reset the camera to factory default settings.
Login	Change the web interface login.
Language	Change the web interface language.
Reboot	Restart your camera.

Set Date/Time	Set the camera date and time.
Power Schedule	Schedule specific times for the camera to reboot or shut down.
Syslog	Turn on to receive technical supports. Enter the <b>IP Address</b> and <b>Port</b> of the receiving device for debug and problem analysis.
Status OSD	Turn on to display preset and zoom ratio on HDMI output.
Setting	Import or export your camera settings
Status Live View	Turn the camera live view on or off.
Export Log	Export system log.
Power Up to Preset	Move the camera to the defined preset after powering on. To enable: 1. Make sure the preset has been defined. 2. Select <b>Power Up to Preset</b> > enter a preset number > click <b>Save</b> .
Power Off to Preset	Move the camera to the defined preset before powering off. To enable: 1. Make sure the preset has been defined. 2. Select <b>Power Off to Preset</b> > enter a preset number > click <b>Save</b> .
Power Off Completely	Select a power setting for your camera. <ul style="list-style-type: none"> <li>On: Shuts down.</li> <li>Off: Enters Standby Mode.</li> </ul>
VISCA Customized Function	Set VISCA customized functions and click <b>OK</b> .
Sleep to Preset	Set up to move the camera to a preset after a delay, when you are not streaming video on Zoom/Teams over USB for enhanced privacy.  <ul style="list-style-type: none"> <li>To enable: <ol style="list-style-type: none"> <li>Make sure you have defined the selected preset.</li> <li>Go to <b>Video &amp; Audio &gt; Theme Mode</b> &gt; select <b>Zoom</b> or <b>Teams</b>.</li> <li>Go to <b>Systems &gt; Sleep to Preset</b> &gt; select a preset or use the default (preset 20, towards I/O ports).</li> <li>Go to <b>Systems &gt; Sleep Timer</b> &gt; select a delay.</li> </ol> </li> <li>To disable, select <b>Off</b> from the <b>Sleep to Preset</b> drop-down list.</li> </ul>
Sleep Timer	
Help Improving AVer Camera	Opt-in or opt-out of providing anonymous usage data.
LED Indicator Brightness	Drag the slider to adjust the brightness.
Camera Selector	Assign a camera select button 1-3 on the remote control to the camera.

	<ul style="list-style-type: none"><li>Both camera and remote control have been set to 1 at the factory.</li></ul>
P/T Reset	Reset the pan-tilt position to the center.
Panning Direction	Invert or reset the pan direction.

# Audio Integrated

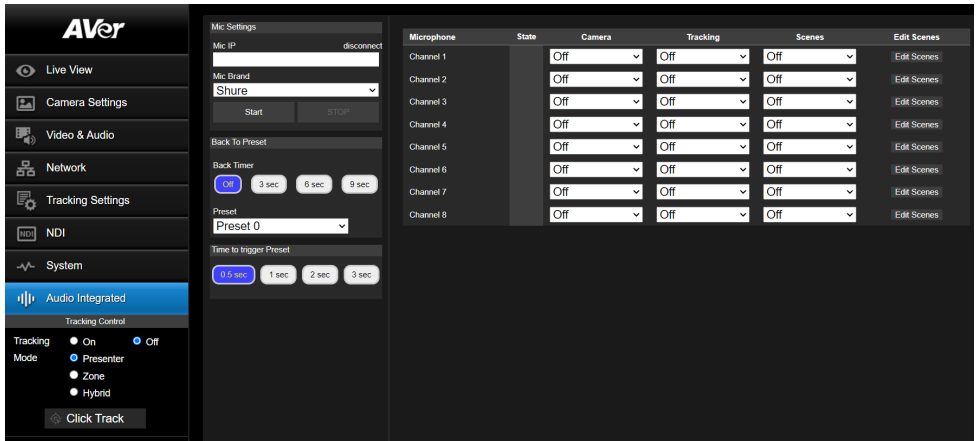

## Supported Microphones

Shure® MXA910 Ceiling Array Microphone

Shure® MXA920-S / MXA920-R Ceiling Array Microphone

Item	Description
Mic Settings	Enter the microphone IP t to connect. Click <b>Start</b> to connect and <b>Stop</b> to disconnect.
Back to Preset	Select a delay before the camera moves to the selected preset.
Time to trigger Preset	Select a delay before the camera moves to the preset when the microphone detects sound.
Mic Manager	<ul style="list-style-type: none"> <li>● Pair microphone channels with presets.</li> <li>● Turn tracking on or off for each channel.</li> <li>● Customize camera functions and add up to 10 CGI commands for each channel.</li> </ul>

# Appendix

## VISCA RS-232 Commands

Command Set	Command	Command Packet	Comments
CAM_Power	On	8x 01 04 00 02 FF	Power ON/OFF
	Off	8x 01 04 00 03 FF	
CAM_Zoom	Stop	8x 01 04 07 00 FF	p=0 (Low) to 7 (High)
	Tele(Variable)	8x 01 04 07 2p FF	
	Wide(Variable)	8x 01 04 07 3p FF	pqrs: Zoom Position · PTC310: 0x0000~0x6f20 PTC330: 0x0110~0x5490
	Direct	8x 01 04 47 0p 0q 0r 0s FF	
CAM_Focus	Stop	8x 01 04 08 00 FF	Each 'Far/Near' needs a 'stop'
	Far (Standard)	8x 01 04 08 02 FF	
	Near (Standard)	8x 01 04 08 03 FF	
	Auto Focus	8x 01 04 38 02 FF	
	Manual Focus	8x 01 04 38 03 FF	
	One Push	8x 01 04 18 01 FF	
	Direct	8x 01 04 47 0p 0q 0r 0s FF	pqrs: Zoom Position
CAM_WB	Auto	8x 01 04 35 00 FF	Normal Auto
	ATW	8x 01 04 35 04 FF	
	Indoor	8x 01 04 35 01 FF	
	Outdoor	8x 01 04 35 02 FF	
	One Push WB	8x 01 04 35 03 FF	One Push WB mode
	Manual	8x 01 04 35 05 FF	Manual Control mode
	One Push	8x 01 04 10 05 FF	One Push WB Trigger
CAM_RGain	Up	8x 01 04 03 02 FF	Manual Control of R Gain
	Down	8x 01 04 03 03 FF	
CAM_Bgain	Up	8x 01 04 04 02 FF	Manual Control of B Gain
	Down	8x 01 04 04 03 FF	

CAM_AE	Full Auto	8x 01 04 39 00 FF	Automatic Exposure mode
	Manual	8x 01 04 39 03 FF	Manual Control mode
	Shutter Priority	8x 01 04 39 0A FF	Shutter Priority Automatic Exposure mode
	Iris Priority	8x 01 04 39 0B FF	Iris Priority Automatic Exposure mode
	Bright	8x 01 04 39 0D FF	Bright Mode (Manual control)
CAM_Shutter	Up	8x 01 04 0A 02 FF	Shutter Setting
	Down	8x 01 04 0A 03 FF	
CAM_Iris	Up	8x 01 04 0B 02 FF	Iris Setting
	Down	8x 01 04 0B 03 FF	
CAM_Gain	Up	8x 01 04 0C 02 FF	Gain Setting
	Down	8x 01 04 0C 03 FF	
CAM_Bright	Up	8x 01 04 0D 02 FF	Bright Setting
	Down	8x 01 04 0D 03 FF	
CAM_Exposure Compensation	Up	8x 01 04 0E 02 FF	Exposure Compensation Amount Setting
	Down	8x 01 04 0E 03 FF	
CAM_Backlight	On	8x 01 04 33 02 FF	Back Light Compensation ON/OFF
	Off	8x 01 04 33 03 FF	
CAM_Preset	Reset	8x 01 04 3F 00 pp FF	pp: Preset Number 0x00~0xFF
	Set	8x 01 04 3F 01 pp FF	
	Recall	8x 01 04 3F 02 pp FF	
CAM_Menu	On/Off	8x 01 06 06 10 FF	Display ON/OFF
Pan-tilt Drive	Up	8x 01 06 01 VV WW 03 01 FF	VV: Pan speed setting 0x01 (low speed) to 0x18 (high speed) WW: Tilt speed setting 0x01 (low speed) to 0x18 (high speed)
	Down	8x 01 06 01 VV WW 03 02 FF	
	Left	8x 01 06 01 VV WW 01 03 FF	
	Right	8x 01 06 01 VV WW 02 03 FF	
	UpLeft	8x 01 06 01 VV WW 01 01 FF	
	UpRight	8x 01 06 01 VV WW 02 01 FF	
	DownLeft	8x 01 06 01 VV WW 01 02 FF	

	DownRight	8x 01 06 01 VV WW 02 02 FF	
	Stop	8x 01 06 01 VV WW 03 03 FF	
	Home	8x 01 06 04 FF	
	Reset	8x 01 06 05 FF	
CAM_WDR	On	8x 01 04 3D 02 FF	Wdr ON/OFF
	Off	8x 01 04 3D 03 FF	
CAM_MenuEnter		8x 01 7E 01 02 00 01 FF	Enter Submenu
Tally Lamp	ON (RED)	8x 01 7E 01 0A 00 02 FF	
	OFF	8x 01 7E 01 0A 00 03 FF	
	ON (AMBER)	8x 01 7E 01 0A 00 04 FF	
	ON (GREEN)	8x 01 7E 01 0A 00 05 FF	
Freeze	Freeze On	81 01 04 62 02 FF	Freeze On Immediately
	Freeze Off	81 01 04 62 03 FF	Freeze Off Immediately
	Preset Freeze On	81 01 04 62 22 FF	Freeze On When Running Preset
	Preset Freeze Off	81 01 04 62 23 FF	Freeze Off When Running Preset
Auto Tracking	On	8x 01 04 7D 02 FF	Auto tracking ON/OFF
	Off	8x 01 04 7D 03 FF	
CAM_Memory Special	Set	8x 01 04 3F 01 pp FF	<p><b>These are changeable depending on VISCA Customized Functions web setting:</b></p> <p>pp: 0x00 To 0xFF normal preset</p> <p>pp: 0x5F =&gt; Turn on OSD menu</p> <p>pp: 0xA0 =&gt; Full Body</p> <p>pp: 0xA1 =&gt; Upper Body</p> <p>pp: 0xA2 =&gt; Tracking Point</p> <p>pp: 0xA3 =&gt; Switch</p> <p>pp: 0xA4 =&gt; Presenter mode</p>

			(supported in FW v25 or newer) pp: 0xA5 => Zone mode (supported in FW v25 or newer) pp: 0xA6 => Hybrid mode (supported in FW v35 or newer)
Absolute Position	Set	8x 01 06 02 VV WW 0Y 0Y 0Y 0Y 0Z 0Z 0Z 0Z FF	VV: Pan speed setting 0x01 (low speed) to 0x18 (high speed) WW: Tilt speed setting 0x01 (low speed) to 0x18 (high speed) YYYY: Pan Position ZZZZ: Tilt Position
Auto zoom	On	8x 01 04 A0 02 FF	
	Off	8x 01 04 A0 03 FF	
Effective Tracking area	On	8x 01 04 A1 02 FF	
	Off	8x 01 04 A1 03 FF	
RTMP	On	8x 01 04 A2 02 FF	
	Off	8x 01 04 A2 03 FF	
Theme mode	Standard	8x 01 04 A3 00 FF	
	ZOOM	8x 01 04 A3 01 FF	
	Teams	8x 01 04 A3 02 FF	
	NDI	8x 01 04 A3 03 FF	
	Portrait	8x 01 04 A3 04 FF	
	Dante	Pending	
Reboot	On	8x 01 04 A4 FF	
Preset Affects PTZ & Focus Values Only	On	8x 01 04 A5 02 FF	
	Off	8x 01 04 A5 03 FF	
Relative Zoom Ratio	On	8x 01 04 A6 02 FF	
	Off	8x 01 04 A6 03 FF	
Auto Tilt	On	8x 01 04 A7 02 FF	
	Off	8x 01 04 A7 03 FF	
Auto Zoom/Tilt preset	Set	8x 01 04 A8 pp FF	pp: 0x00 To 0xFF normal preset

Multi presenter	On	8x 01 04 A9 02 FF	
	Off	8x 01 04 A9 03 FF	
Multi presenter preset	Set	8x 01 04 AA pp FF	pp: 0x00 To 0xFF normal preset

Inquiry Command	Command Packet	Reply Packet	Comments
CAM_PowerInq	8x 09 04 00 FF	y0 50 02 FF	On
		y0 50 03 FF	Off
CAM_WBModelInq	8x 09 04 35 FF	y0 50 00 FF	Auto
		y0 50 01 FF	In Door
		y0 50 02 FF	Out Door
		y0 50 03 FF	One Push WB
		y0 50 04 FF	ATW
		y0 50 05 FF	Manual
CAM_RGainInq	8x 09 04 43 FF	y0 50 00 00 0p 0q FF	pp: R Gain
CAM_BGainInq	8x 09 04 44 FF	y0 50 00 00 0p 0q FF	pp: B Gain
CAM_AEModelInq	8x 09 04 39 FF	y0 50 00 FF	Full Auto
		y0 50 03 FF	Manual
		y0 50 0A FF	Shutter Priority
		y0 50 0B FF	Iris Priority
		y0 50 0D FF	Bright
CAM_ShutterPosInq	8x 09 04 4A FF	y0 50 00 00 0p 0q FF	pp: Shutter Position
CAM_IrisPosInq	8x 09 04 4B FF	y0 50 00 00 0p 0q FF	pp: Iris Position
CAM_GainPosInq	8x 09 04 4C FF	y0 50 00 00 0p 0q FF	pp: Gain Position
CAM_BrightPosInq	8x 09 04 4D FF	y0 50 00 00 0p 0q FF	pp: Bright Position
CAM_ExpCompPosInq	8x 09 04 4E FF	y0 50 00 00 0p 0q FF	pp: ExpComp Position
CAM_FocusModelInq	8x 09 04 38 FF	y0 50 02 FF	Auto Focus
		y0 50 03 FF	Manual Focus
CAM_FocusPosInq	8x 09 04 48 FF	y0 50 0p 0q 0r 0s FF	ppqr: Focus Position
zoom_Pos_Inq	8x 09 04 47 FF	y0 50 0p 0q 0r 0s FF	ppqr: Zoom Position

PT_Pos_Inq	8x 09 06 12 FF	y0 50 0Y 0Y 0Y 0Y 0Z 0Z 0Z 0Z FF	YYYY: Pan Position ZZZZ: Tilt Position
CAM_Preset Inq	8x 09 04 3F FF	y0 50 pp FF	Return the last preset number which has been operated pp:01-FF
CAM_Tracking status	8x 09 36 69 02 FF	y0 50 01 FF	On
		y0 50 00 FF	Off
CAM_Tracking_mode	8x 09 36 69 01 FF	y0 50 01 FF	Presenter
		y0 50 02 FF	Zone
		y0 50 03 FF	Hybrid
CAM_Tracking body size	8x 09 36 69 03 FF	y0 50 01 FF	Full body
		y0 50 02 FF	Upper body
CAM_OSD MENU on/off	8x 09 7E 04 76 01 FF	y0 50 02 FF	On
		y0 50 03 FF	Off
CAM_Tally	8x 09 7E 01 0A FF	y0 50 02 FF	On
		y0 50 03 FF	Off
CAM_WDR mode	8x 09 04 3D FF	y0 50 02 FF	On
		y0 50 03 FF	Off
CAM_BLC mode	8x 09 04 33 FF	y0 50 02 FF	On
		y0 50 03 FF	Off
CAM_Live Freeze	8x 09 04 62 01 FF	y0 50 02 FF	Freeze On
		y0 50 03 FF	Freeze Off
CAM_Preset Freeze	8x 09 04 62 02 FF	y0 50 02 FF	Preset Freeze On
		y0 50 03 FF	Preset Freeze Off
Firmware version	8x 09 36 69 04 FF	y0 50 0p 0q 0r 0s 0t 0u 0v 0w FF	fw_ver: p.q.rstu.vw
USB Status	8x 09 36 69 05 FF	y0 50 00 FF	USB cable plug out
		y0 50 01 FF	USB cable plug in
UVC Status	8x 09 36 69 06 FF	y0 50 00 FF	UVC stream off
		y0 50 01 FF	UVC stream on

# VISCA over IP Settings

## PORT

Internet protocol	IPv4
Transport protocol	UDP
Port address	52381

## FORMAT

	byte 0	byte 1	byte 2	byte 3	byte 4	byte 5	byte 6	byte 7	byte8 ~~~ byte23	
func	Payload type		Payload length		Sequence number			Payload (1 to 16 bytes)		
data	Value1	Value2	1~16 (0x0001~0x0010)		0X00000000 ~ 0XFFFFFFF			VISCA Packet (see page VISCA)		

## Payload type

Name	Value1	Value2	Description
VISCA command	0x01	0x00	Stores the VISCA command.
VISCA inquiry	0x01	0x10	Stores the VISCA inquiry.
VISCA reply	0x01	0x11	Stores the reply for the VISCA command or VISCA inquiry

For VISCA over IP command strings, **8x** represents a command from the controller, with x as the socket number—typically 1 (**x = 1 → 81**).

Command Set	Command	Command Packet	Comments
Pan-tilt Drive	Left	8x 01 06 01 VV WW 01 03 FF Example : 01 00 00 09 00 00 00 01 81 01 06 01 07 07 01 03 FF	VV: Pan speed setting 0x01 (low speed) to 0x18 (high speed) WW: Tilt speed setting 0x01 (low speed) to 0x18 (high speed)

Controller

Device

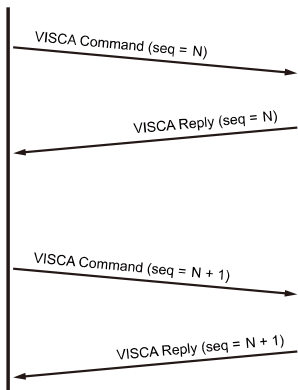

## CGI Commands

CGI List for Video Transmission					
CGI item name	URL	Command	Parameter Name	Parameter value	Description
Get JPEG	/snapshot				1280x720 jpg
Get RTSP stream	rtsp://ip/live_st1				
CGI List for Camera Control					
CGI item name	URL	Command	Parameter Name	Parameter value	Description
up start	/cgi-bin?SetPtzf=	1,0,1&(random)			
up end	/cgi-bin?SetPtzf=	1,0,2&(random)			
down start	/cgi-bin?SetPtzf=	1,1,1&(random)			
down end	/cgi-bin?SetPtzf=	1,1,2&(random)			
left start	/cgi-bin?SetPtzf=	0,1,1&(random)			
left end	/cgi-bin?SetPtzf=	0,1,2&(random)			
right start	/cgi-bin?SetPtzf=	0,0,1&(random)			
right end	/cgi-bin?SetPtzf=	0,0,2&(random)			
zoom_in start	/cgi-bin?SetPtzf=	2,0,1&(random)			
zoom_in end	/cgi-bin?SetPtzf=	2,0,2&(random)			
zoom_out start	/cgi-bin?SetPtzf=	2,1,1&(random)			
zoom_out end	/cgi-bin?SetPtzf=	2,1,2&(random)			
set preset:	/cgi-bin?ActPreset=	1,N&(random)			N : position
load preset:	/cgi-bin?ActPreset=	0,N&(random)			N : position
set preset speed	/cgi-bin?Set=preset_speed,3,val	val: {min: 1, max: 6}			
Absolute Position (Pan)	/cgi-bin?Set=ptz_p,3,val	val: {min: 5088, mid: 965104, max: 1925120}			Follows CGI preset speed
Absolute Position (Tilt)	/cgi-bin?Set=ptz_t,3,val	val: {min: 2048, mid: 962560, max: 650240}			Follows CGI preset speed

Absolute Position (Zoom)	/cgi-bin?Set=ptz_z,3,val	val: {min: 250, mid: 11618, max: 23002}			Follows CGI preset speed
Flip on	/cgi-bin?Set=img_flip,3,1				
Flip off	/cgi-bin?Set=img_flip,3,0				
USB Isochronous transfer mode	/cgi-bin?Set=usb_bulk_mode_en,3,val	val: { 0: Isochronous 1: Bulk }			
Set theme mode	/cgi-bin?Set=sys_theme_mode,3,val	val: { 0 : Standard 1 : Zoom 2 : Teams 3 : NDI 4 : portrait 7 : Dante }			

#### CGI List for Various Settings

CGI item name	URL	Command	Parameter Name	Parameter value	Description
exposure value	/cgi-bin?Set=	img_expo_expo,3,N&(random)	value	1 ~ 9	N : value
saturation	/cgi-bin?Set=	img_saturation,3,N&(random)	value	0 ~ 10	N : value
contrast	/cgi-bin?Set=	img_contrast,3,N&(random)	value	0 ~ 4	N : value
Tracking on:	/cgi-bin?Set=	trk_tracking_on,3,1			
Tracking off:	/cgi-bin?Set=	trk_tracking_on,3,0			
Reboot	GET(Basic Authentication)	/cgi-bin?OnePush=!			
Factory Reset	GET(Basic Authentication)	/cgi-bin?OnePush=d			
Mode Presenter		/cgi-bin?Set=trk_mode,3,1&X	value	random number	X : value
Mode Zone		/cgi-bin?Set=trk_mode,3,2&X	value	random number	X : value
Mode Hybrid		/cgi-bin?Set=trk_mode,3,3&X			

Mode Framing		/cgi-bin?Set=trk_mode,3,6&X			
Mode Get	GET(Basic Authentication)	/cgi-bin?Get=trk_mode,3&_X	- Reply	Presenter trk_mode,3=1 Zone trk_mode,3=2 Hybrid trk_mode,3=3 Framing trk_mode,3=6	X : value
Click Track ON	GET(Basic Authentication)	/cgi-bin?Set=trk_update_detect,3,1			
Click Track OFF	GET(Basic Authentication)	/cgi-bin?Set=trk_update_detect,3,0			
Click Track Get detect zone (Humanoid outlines) number	GET(Basic Authentication)	/cgi-bin?Get=trk_detect_num,3			Need to be sent along with Click Track ON command
	- Reply	"trk_detect_num,3=X\r\n"	X: The amount of humanoid outlines, maximum: 50		
Click Track Get detect zone (Humanoid outlines) info	GET(Basic Authentication)	/cgi-bin?GetTrackingDetectZone=X	X: The amount of humanoid outlines, maximum: 50		
	- Reply	"focus:-1\nzone[00]:00,119,720,960\nzone[01]:-1502615204,-1366225632,01,-1366223544"	focus - The number of humanoid outline being tracked.  zone[NN]:x,y,w,h - based on 1080P resolution	The upper left corner of the screen is the coordinate reference (0,0), x-coordinate/y-coordinate/w width/h height, based on the upper left corner of the humanoid outline.  The number following indicates the number of the tracked person, for example, -1 means that no one is being tracked. If one of the three is	

				being tracked, one of 0, 1 and 2 will appear after the 'focus'.	
Click Track Set target zone	GET(Basic Authentication)	/cgi-bin?Set=trk_asign_zone,3,X	X: The number of the human outlines		
	- Reply	http response: ok			
	GET(Basic Authentication)	/cgi-bin?SetString=TrackingFocusZone,[x,y,w,h]			
	- Reply	http response: ok			
Tracking On/Off Get	GET(Basic Authentication)	/cgi-bin?Get=trk_tracking_on,3&_=X	- Reply	On  trk_tracking_on,3=1 Off  trk_tracking_on,3=0"	X : value
RTMP Start streaming	/cgi-bin?Set=	vdo_rtmp_enable,3,1			
RTMP Stop streaming	/cgi-bin?Set=	vdo_rtmp_enable,3,0			
USB status	GET(Basic Authentication)	/cgi-bin?Get=usb_status_inquire,3			
	- Reply	"usb_status_inquire,3=X\r\n"	X: 0(plug out), 1(plug in)		
UVC status	GET(Basic Authentication)	/cgi-bin?Get=uvc_status_inquire,3			
	- Reply	"uvc_status_inquire,3=X\r\n"	X: 0(stream off), 1(stream on)		
Status get (Modle name & mac & FW_VER)		/cgi-bin?GetString=sys_name&net_mac&sys_fw_version&_=1635216271678		http://10.100.105.110/cgi-bin?GetString=sys_name&net_mac&sys_fw_version&_=1635216271678	
Serial No. get		/cgi-bin?GetSerialNumber&_=1635216271680		http://10.100.105.110/cgi-bin?GetSerialNumber&_=1635216271680	

<p>script (Using cURL to update firmware)</p>	<pre>curl.exe -X POST --user NAME:PASSW ORD -F file1=@./ISP_FI LE "http://IP_ADD RESS/system/"</pre>			<p>Please download curl (curl for Windows), this is a command line tool for network transferring. Put curl.exe and ISP file in the same folder. and then execute the script to upgrade camera.</p> <p>For example, ISP file is 0. 0.0000.29.dat , IP address is 10.100.105.109 and username:pass word is 1:1 , you can enter this script to execute ISP process.</p> <pre>curl.exe -X POST --user 1:1 -F file1=@./0.0.00 00.29.dat "http://10.100.1 05.109/system/ "</pre>	
-----------------------------------------------------------	------------------------------------------------------------------------------------------------------	--	--	------------------------------------------------------------------------------------------------------------------------------------------------------------------------------------------------------------------------------------------------------------------------------------------------------------------------------------------------------------------------------------------------------------------------------------------------------------------------------------------------------------------------------------------------------------------------------------	--

# Pelco P Commands

PTC300V2 Pelco-P command

PAN AND TILT COMMANDS		P/T bit(byte4.0) = 0						
func	byte 1	byte 2	byte 3	byte 4	byte 5	byte 6	byte 7	byte 8
STX	ADDR	data1	data2	data3	data4	ETX	checksum	
data	0xA0	0~7F	cmd 1	cmd 2	Pan speed	Tilt speed	0xAF	1~7 XOR

note : speed = 0x00~0x30

byte3 : command 1

bit 7	bit 6	bit 5	bit 4	bit 3	bit 2	bit 1	bit 0
NA	CAM ON	NA	CAM ON/OFF	NA	NA	NA	NA

note : power off : byte3.6 = 0 & byte3.4 = 1

byte4: command 2

bit 7	bit 6	bit 5	bit 4	bit 3	bit 2	bit 1	bit 0
NA	ZOOM Wide	ZOOM Tele	TILT Down	TILT Up	PAN Left	PAN Right	P/T bit 0(always)

EXTENDED COMMAND SET P/T bit(byte4.0) = 1

func	byte 1	byte 2	byte 3	byte 4	byte 5	byte 6	byte 7	byte 8
STX	ADDR	data1	data2	data3	data4	ETX	checksum	
Set Preset XX	0xA0	0~7	0x00	0x03	0x00	Preset #	0xAF	1~7 XOR
Go To Preset XX	0xA0	0~7	0x00	0x07	0x00	Preset #	0xAF	1~7 XOR
Track ON	0xA0	0~7	0x00	0x65	0x00	0x00	0xAF	1~7 XOR
Track OFF	0xA0	0~7	0x00	0x67	0x00	0x00	0xAF	1~7 XOR

note : Preset # : 0x01 ~ 0xFF  
Profile # : 0x01 ~ 0x05

# Pelco D Commands

pelco d command

PAN AND TILT COMMANDS		P/T bit(byte4.0) = 0					
func	byte 1	byte 2	byte 3	byte 4	byte 5	byte 6	byte 7
SYNC	ADDR	cmd 1	cmd 2	data1	data2	checksum	
data	0xFF	1~80	cmd 1	cmd 2	Pan speed	Tilt speed	2~6 SUM

note : speed = 0x00~0x30

byte3 : command 1

bit 7	bit 6	bit 5	bit 4	bit 3	bit 2	bit 1	bit 0
SENSE ON	NA	NA	NA	CAM ON/OFF	NA	NA	NA

note : power off : byte3.7 = 0 & byte3.3 = 1

byte4: command 2

bit 7	bit 6	bit 5	bit 4	bit 3	bit 2	bit 1	bit 0
NA	ZOOM Wide	ZOOM Tele	TILT Down	TILT Up	PAN Left	PAN Right	P/T bit 0(always)

EXTENDED COMMAND SET P/T bit(byte4.0) = 1

func	byte 1	byte 2	byte 3	byte 4	byte 5	byte 6	byte 7
SYNC	ADDR	data1	data2	data3	data4	checksum	
Set Preset XX	0xFF	1~8	0x00	0x03	0x00	Preset #	2~6 SUM
Go To Preset XX	0xFF	1~8	0x00	0x07	0x00	Preset #	2~6 SUM
Track ON	0xFF	1~8	0x00	0x65	0x00	0x00	2~6 SUM
Track OFF	0xFF	1~8	0x00	0x67	0x00	0x00	2~6 SUM

note : Preset # : 0x01 ~ 0xFF

Example:

Camera Address: 1

Pan Left at high speed: FF 01 00 04 3F 00 44

Pan Right at medium speed: FF 01 00 02 20 00 23

Tilt Up at high speed: FF 01 00 08 00 3F 48

Tilt Down at medium speed: FF 01 00 10 20 00 31

Stop all actions (Pan / Tilt / Zoom / Iris etc.): FF 01 00 00 00 00 01