

Professional PTZ Camera

— User Manual —

PTZ211 / PTZ310UV2 / PTZ310UNV2
PTZ231 / PTZ330UV2 / PTZ330UNV2

Warning

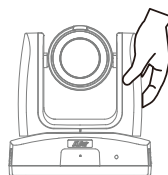
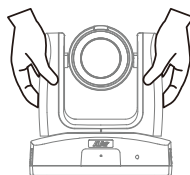
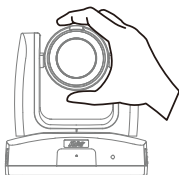
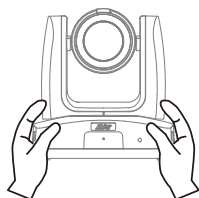

- To reduce the risk of fire or electric shock, do not expose this appliance to rain or moisture. Warranty will be void if any unauthorized modifications are done to the product.
- Do not drop the camera or subject it to physical shock.
- Use the correct power supply voltage to avoid the damaging camera.
- Do not place the camera where the cord can be stepped on as this may result in fraying or damage to the lead or the plug.
- Hold the bottom of the camera with both hands to move the camera. Do not grab the lens or lens holder to move the camera.

Federal Communications Commission

NOTE: This equipment has been tested and found to comply with the limits for a Class A digital device, pursuant to part 15 of the FCC Rules. These limits are designed to provide reasonable protection against harmful interference when the equipment is operated in a commercial environment. This equipment generates, uses, and can radiate radiofrequency energy and, if not installed and used in accordance with the instruction manual, may cause harmful interference to radio communications. Operation of this equipment in a residential area is likely to cause harmful interference in which case the user will be required to correct the interference at his own expense.

FCC Caution: Any changes or modifications not expressly approved by the party responsible for compliance could void the user's authority to operate this equipment.

This device complies with part 15 of the FCC Rules.

Operation is subject to the following two conditions:

- (1) This device may not cause harmful interference, and
- (2) this device must accept any interference received, including interference that may cause undesired operation.

This Class A digital apparatus complies with Canadian ICES-003. Cet appareil numérique de la classe A est conforme à la norme NMB-003 du Canada.

PSTI Statement of Compliance

Please refer to the following website: <https://www.aver.com/product-security-advisory>

Warning

This is a class A product. In a domestic environment, this product may cause radio interference in which case the user may be required to take adequate measures.

Caution

Risk of explosion if battery is replaced by an incorrect type. Dispose of used batteries according to the instructions.

VCCI-A

この装置は、クラス A 機器です。この装置を住宅環境で使用すると電波妨害を引き起こすことがあります。この場合には使用者が適切な対策を講ずるよう要求されることがあります。

(注)本製品同梱の電源ケーブルは、本製品同梱の電源アダプタでのみ使用してください。本製品同梱の電源ケーブルは、他の電気機器では使用できません。

사용자안내문

이 기기는 업무용 환경에서 사용할 목적으로 적합성평가를 받은 기기로서 가정용 환경에서 사용하는 경우 전자파간섭의 우려가 있습니다.

※ 사용자 안내문은 "업무용 방송통신기자재"에만 적용됩니다.

기종별

사용자안내문

A 급 기기
(업무용 방송통신기자재)

이 기기는 업무용(A 급) 전자파적합기기로서 판매자 또는 사용자는 이 점을 주의하시기 바라며, 가정외의 지역에서 사용하는 것을 목적으로 합니다.

DISCLAIMER

No warranty or representation, either expressed or implied, is made with respect to the contents of this documentation, its quality, performance, merchantability, or fitness for a particular purpose. Information presented in this documentation has been carefully checked for reliability; however, no responsibility is assumed for inaccuracies. The information contained in this documentation is subject to change without notice.

In no event will AVer Information Inc. be liable for direct, indirect, special, incidental, or consequential damages arising out of the use or inability to use this product or documentation, even if advised of the possibility of such damages.

TRADEMARKS

"AVer" is a trademark owned by AVer Information Inc. Other trademarks used herein for description purpose only belong to each of their companies.

All HDMI trademarks and trade dress are registered trademarks or trademarks of HDMI Licensing Administrator, Inc.

COPYRIGHT

©2026 AVer Information Inc. All rights reserved. | March 19, 2026

All rights of this object belong to AVer Information Inc. Reproduced or transmitted in any form or by any means without the prior written permission of AVer Information Inc. is prohibited. All information or specifications are subject to change without prior notice.

More Help

For FAQs, technical support, software and user manual download, please visit:

Non-USA

Download Center: <https://www.aver.com/download-center>

Technical Support: <https://www.aver.com/technical-support>

USA

Download Center: <https://www.averusa.com/pro-av/support>

Technical Support: <https://averusa.force.com/support/s/contactsupport>

Contact Information

Headquarters

AVer Information Inc.
8F, No.157, Da-An Rd.,
Tucheng Dist., New Taipei City
236042, Taiwan
Tel: +886 (2) 2269 8535

USA Branch Office

AVer Information Inc., Americas
44061 Nobel Drive, Fremont, CA
94538, USA
Tel: +1 (408) 263 3828
Toll-free: +1 (877) 528 7824

Europe Branch Office

AVer Information Europe B.V.
Westblaak 134, 3012 KM,
Rotterdam, The Netherlands
Tel: +31 (0) 10 7600 550

Japan Branch Office

アバー・インフォメーション株式会社
〒160-0023 日本東京都新宿区
西新宿 3-2-26 立花新宿ビル
7 階
Tel: +81 (0) 3 5989 0290
お客様サポートセンター(固定電
話のみ): +81 (0) 120 008 382

Vietnam Branch Office

Công ty TNHH AVer Information
(Việt Nam)
Tầng 5, 596 Nguyễn Đình
Chiểu, P.3, Quận 3, Thành phố
Hồ Chí Minh 700000, Việt Nam
Tel: +84 (0) 28 22 539 211
Hỗ trợ kỹ thuật: +84 (0) 90 70
080 77

Korea Office

한국 에버 인포메이션 (주)
서울시 종로구 새문안로 92
(신문로 1 가,
광화문오피시아빌딩) 1831,
1832 호
Tel: +82 (0) 2 722 8535

Contents

Warning	2
Overview	1
Package Contents	1
Optional Accessories	1
Parts Info	2
LED Indicator	3
Dimensions	3
Pan and Tilt Angle	5
Remote Control	6
Shortcuts	7
Installation	8
Mounting Measurements	8
Cable Fixing Plate Installation	8
Ceiling Mount Installation	9
Connection	10
Device Connection	10
PoE Connection	10
RS-232 Connection	11
RS-422 Connection	13
Audio Input Connection	15
Video Output Connection	15
Get Started	16
Power the Device On and Off	16
Reset the Device	16

Factory Default Settings	16
Access the OSD Menu	16
Change Your Network Setting	17
OSD Menu Tree	19
Access the Web Interface	22
AVer Device Utility	22
AVer Enterprise Management	23
Log in for the First Time.....	23
Web Interface.....	24
Live View	24
Camera Control	24
Preset	25
Camera Settings	27
Exposure	27
Image Process	28
Video & Audio	30
Output Interface and Resolution Table.....	31
Network.....	33
Advanced Settings.....	37
SmartShoot	37
Framing	39
NDI.....	41
System.....	43
Audio Integrated	45
Supported Microphones	45
Appendix.....	46
VISCA RS-232 Commands	46
VISCA over IP Settings.....	52

Overview

Package Contents

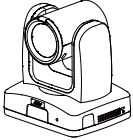

Camera

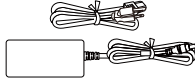

Power Adapter &
Power Cord

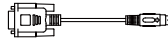

DIN8 to D-Sub9
Cable



RS-232 In/Out
Y Cable

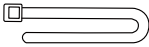

Cable Ties (x4)



Remote Control



Cable Fixing Plate

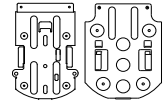

Ceiling Mount Bracket
(x2)



M2 x 4mm
Screw (x3)



M3 x 6mm
Screw (x3)



1/4\"-20, L=6.5mm
Screw (x2)



Drill Template

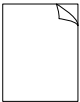

Quick Start Guide

Optional Accessories

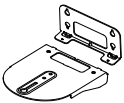

Wall Mount Bracket

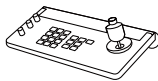

Camera Controller
(CL01)

* For details on optional accessories, please consult with your local dealer.

Parts Info

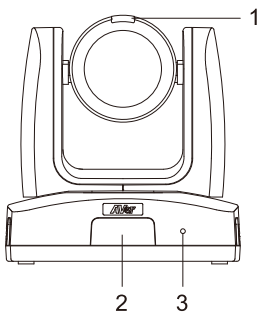

1. Tally Lamp
2. IR Sensor
3. LED Indicator

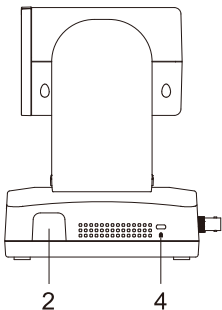

4. Kensington Lock

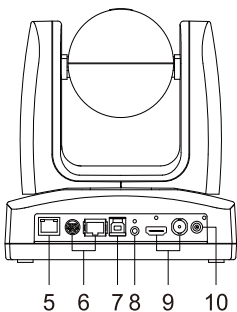

5. PoE+ 802.3at Port
6. Control Ports
RS-232 / RS-422
7. USB 3.0 Type-B Port
8. Audio In
Line input level: 1Vrms max.
Mic input level: 50mVrms max.; supplied voltage: 2.5V.
9. Video Output Ports
HDMI® / 3G-SDI
10. DC Power Jack

LED Indicator

Color	Status
Flashing orange	Start-up
Solid orange	Standby
Solid blue	Operational
Flashing purple	SmartShoot
Flashing blue	Framing
Flashing red	Firmware update

Dimensions

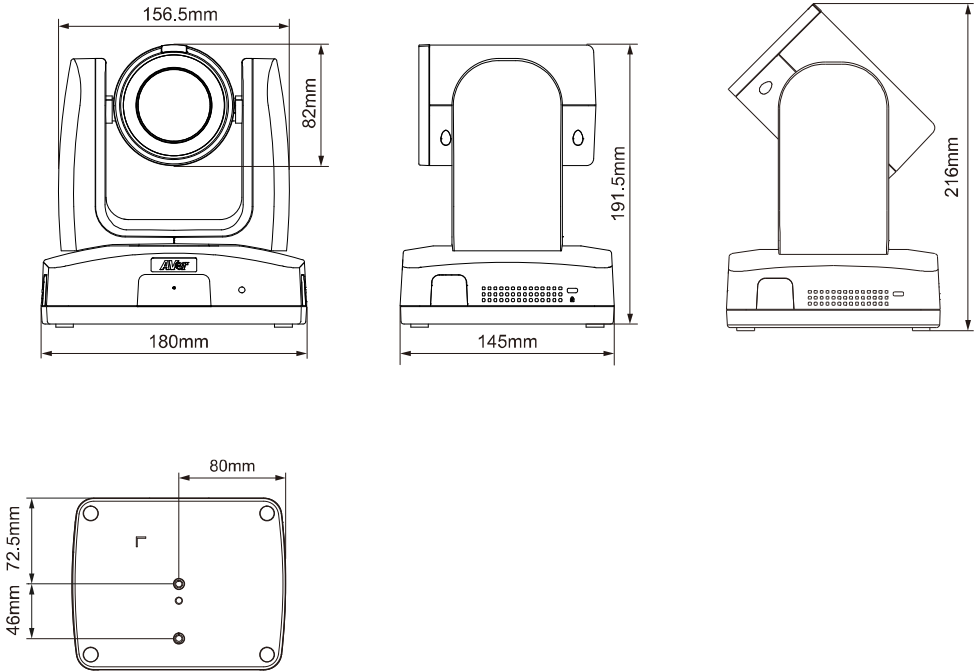

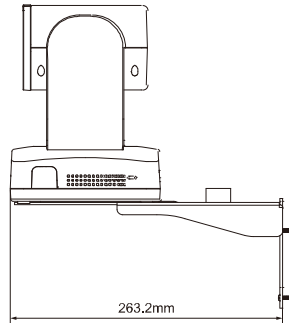
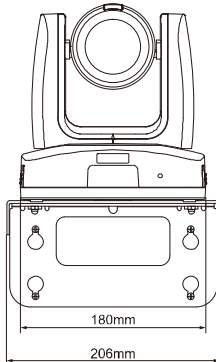
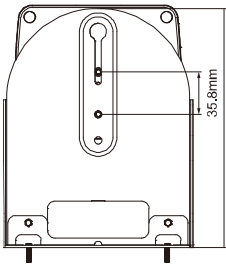
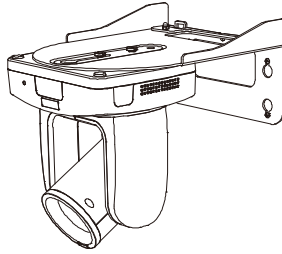
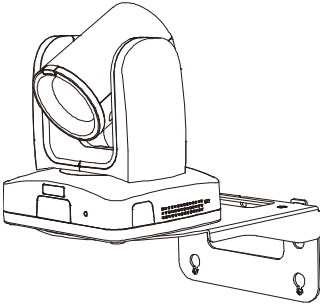
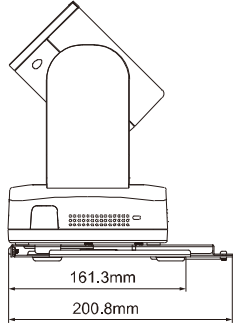
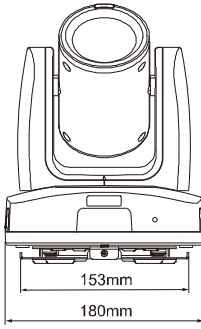
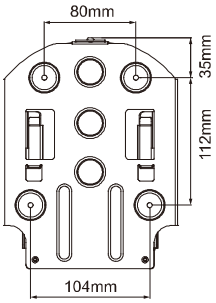
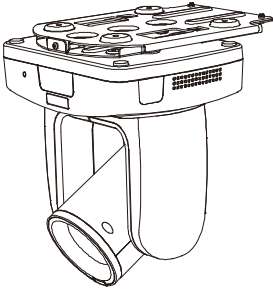

Pan and Tilt Angle

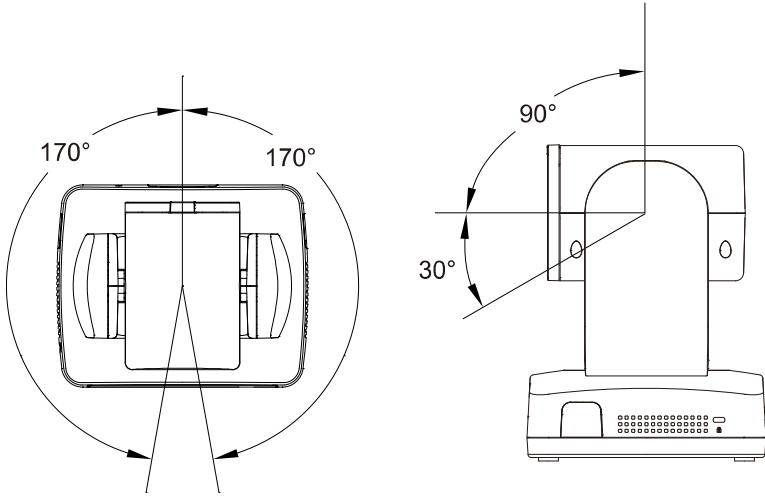

Remote Control

Your device may come with one of the following remote controls.

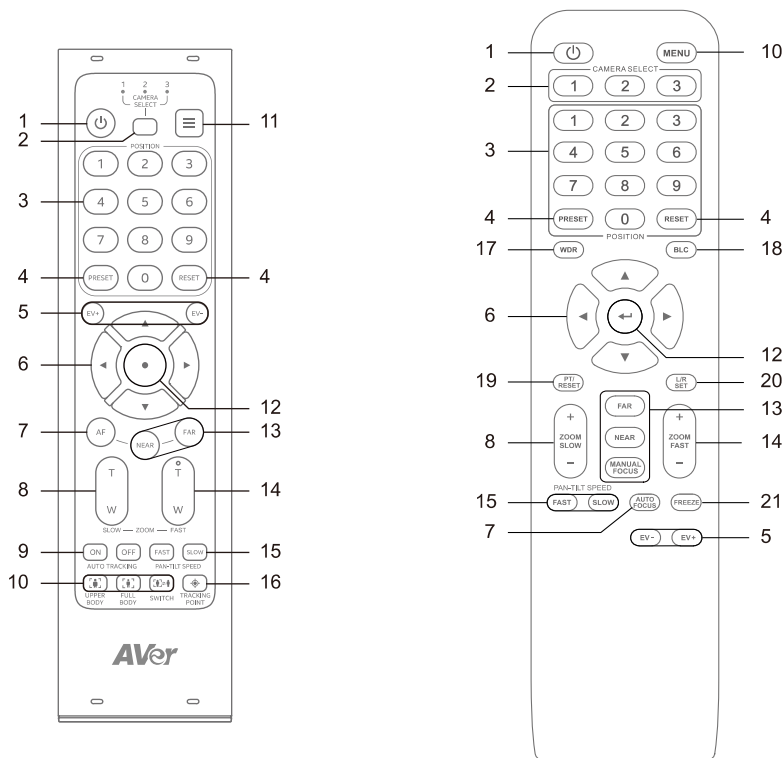

Name	Function
1. POWER	Enter Standby Mode or wake up.
2. CAMERA SELECT	No selection is required to operate the camera by default. <ul style="list-style-type: none"> Both camera and remote control have been set to 1 at the factory. To assign a number to the camera, go to System > Camera Selector in the OSD menu.
3. NUMBER BUTTONS	Press Number button (0-9) to load defined preset 0-9.
4. PRESET/RESET	<ul style="list-style-type: none"> To save a preset, press and hold PRESET, then press a Number button (0-9). To clear a preset, press and hold RESET, then press a Number button (0-9).
5. EV +/-	<ul style="list-style-type: none"> Press to adjust exposure value. Press and hold EV+ to turn on RTMP. Press and hold EV- to turn off RTMP.

6. PAN-TILT CONTROL	Pan and tilt direction control.
7. AF	Turn on Auto Focus.
8. ZOOM SLOW	Zoom in or out slowly.
9. AUTO TRACKING	N/A
10. FRAME PRESENTER	<ul style="list-style-type: none"> • Upper Body: N/A • Full Body: N/A • Switch: N/A
11. MENU	Open or close the OSD menu during HDMI output.
12. ENTER	<ul style="list-style-type: none"> • Confirm a selection in the OSD menu. • Press to One Push Focus (auto focus once). • Press and hold to Framing (frame entire group on screen) once. Framing must be turned on in the OSD menu first, go to Advanced Settings > Framing > Manual.
13. NEAR / FAR / MANUAL FOCUS	Press NEAR or FAR to adjust focus manually. Or press MANUAL FOCUS , if available, to turn on Manual Focus first, then press NEAR or FAR to adjust focus manually.
14. ZOOM FAST	Zoom in or out fast.
15. PAN-TILT SPEED	Adjust pan-tilt speed.
16. TRACKING POINT	N/A
17. WDR	Turn Wide Dynamic Range on or off.
18. BLC	Turn Backlight Compensation on or off.
19. PT RESET	Reset the pan-tilt position to the center.
20. L/R SET	<ul style="list-style-type: none"> • To invert L/R pan direction, press and hold L/R SET, then press Number button 2. • To reset L/R pan direction, press and hold L/R SET, then press Number button 1.
21. FREEZE	Freeze or unfreeze the live view.

Shortcuts

Press	To
6 six times (666666)	Reset the device to factory default settings.
7 seven times (7777777)	Display the human tracking frame on the HDMI output.
8 eight times (88888888)	Set the network setting to static IP 192.168.1.168.
9 nine times (999999999)	Clear the web interface login. You'll be prompted to change the username and password on your next login.

Installation

Mounting Measurements

- Motion tracking

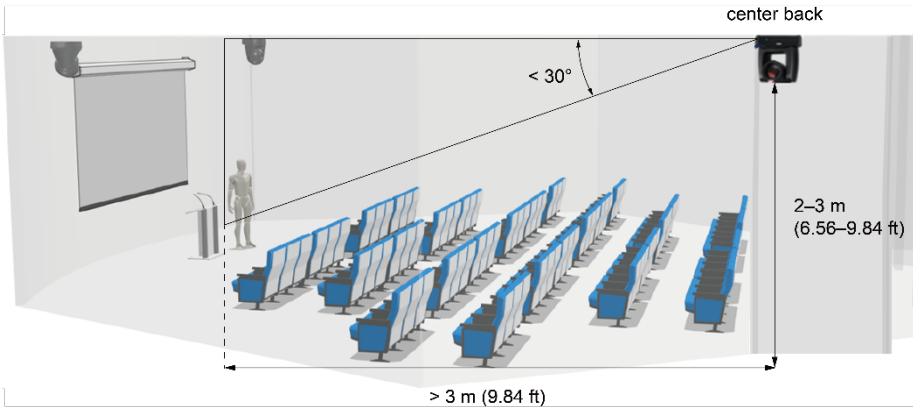

Optical zoom	Distance from subject	Distance from subject	Can be inverted
	Upper body	Full body	
12X	3-16m	3-28m	Yes
16X	3-30m	4-55m	Yes
21X	3-40m	4-65m	Yes
30X	3-44m	3-76m	Yes

Cable Fixing Plate Installation

1. Secure the cable fixing plate to the camera with the included M2 x 4 mm screws (x3).
2. Connect the cables.
3. Use the cable ties to secure the cables to the cable fixing plate.

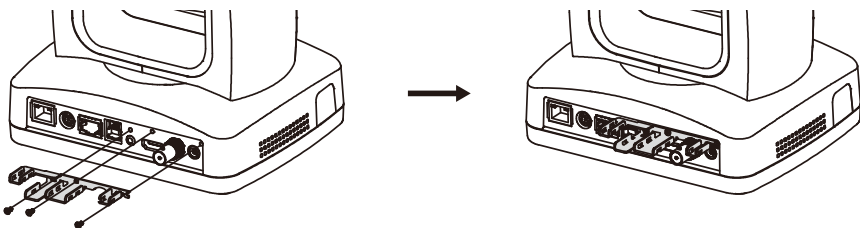

Ceiling Mount Installation

1. Secure the mount bracket on the ceiling.
Screw: 4 screws, M4 x 10mm (not included)

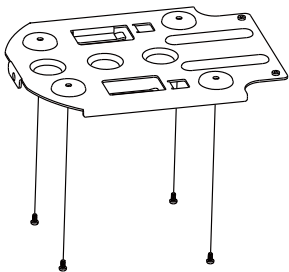

2. Install the mount bracket on the camera.
Screw: 2 screws, 1/4"-20 L=6.5mm (included)

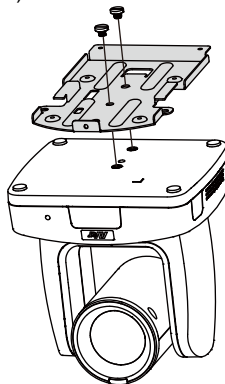

3. Slide the mount bracket with the camera into the mount bracket which secured on the ceiling. And connect the cables.

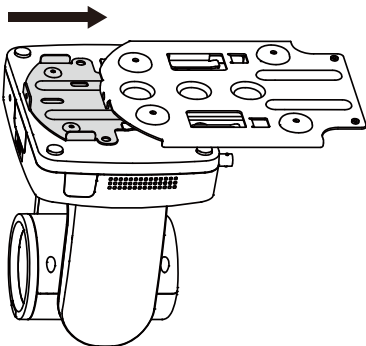

4. Secure the camera with screws.
Screw: 3 screws, M3 x 6mm (included)

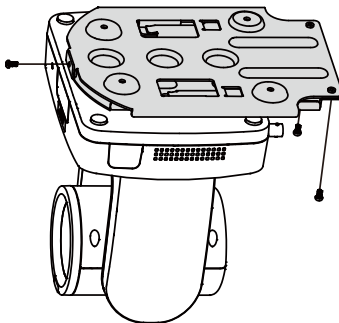

Connection

Device Connection

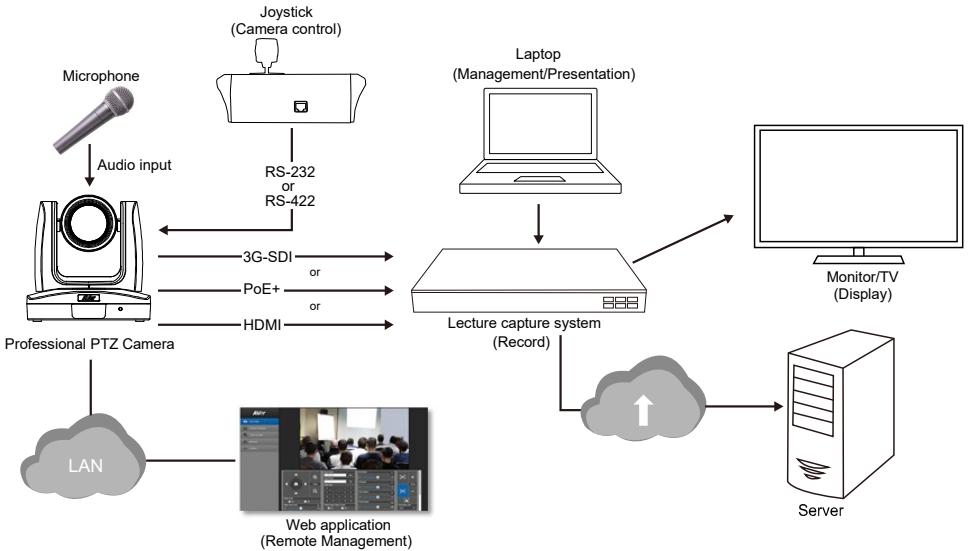

PoE Connection

Connect the camera PoE++ 802.3at port to a port on the Ethernet switch. The switch must provide PoE++ if you are not using a power adapter.

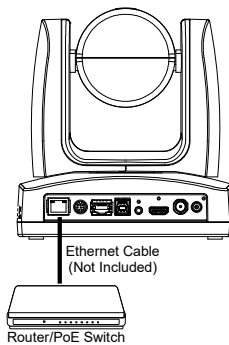

RS-232 Connection

Connect through the RS-232 for camera control.

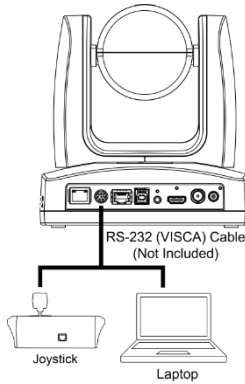

- RS-232 mini DIN9 to mini DIN8 Cable Pin Definition**

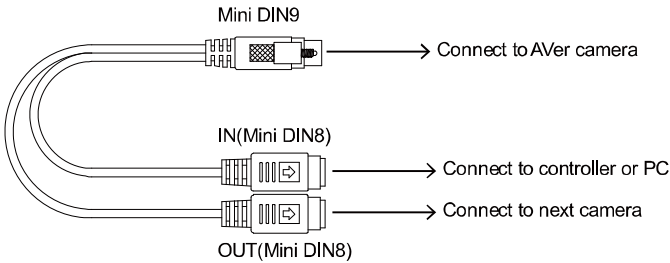

- Mini DIN9 to Mini DIN8 RS-232 Adaptor Cable Pin Definition**

Circuits:

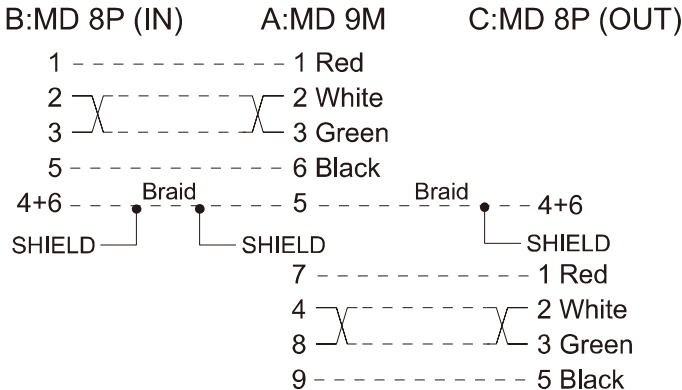

- RS-232 Pin Definition

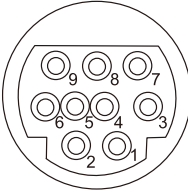

Function	Mini DIN9 Pin #	I/O Type	Signal	Description
VISCA IN	1	Output	DTR	Data Terminal Ready
	2	Input	DSR	Data Set Ready
	3	Output	TXD	Transmit Data
	6	Input	RXD	Receiver Data
VISCA OUT	7	Output	DTR	Data Terminal Ready
	4	Input	DSR	Data Set Ready
	8	Output	TXD	Transmit Data
	9	Input	RXD	Receiver Data
	5	Input	I/O	Detect DIN8/DIN9
---	Shield	---	GND	Ground

- Mini DIN8 Cable Pin Definition

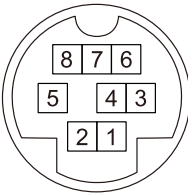

Pin #	Signal
1	DTR
2	DSR
3	TXD
4	GND
5	RXD
6	GND
7	NC
8	NC

- Din8 to D-Sub9 Cable Pin Definition

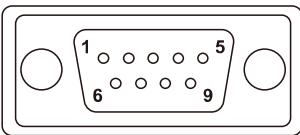

PIN Out:

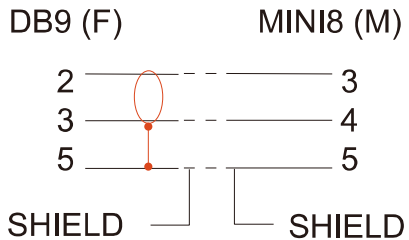

RS-422 Connection

Use an RS-422 adapter cable to make a RS-422 connection to your control device.

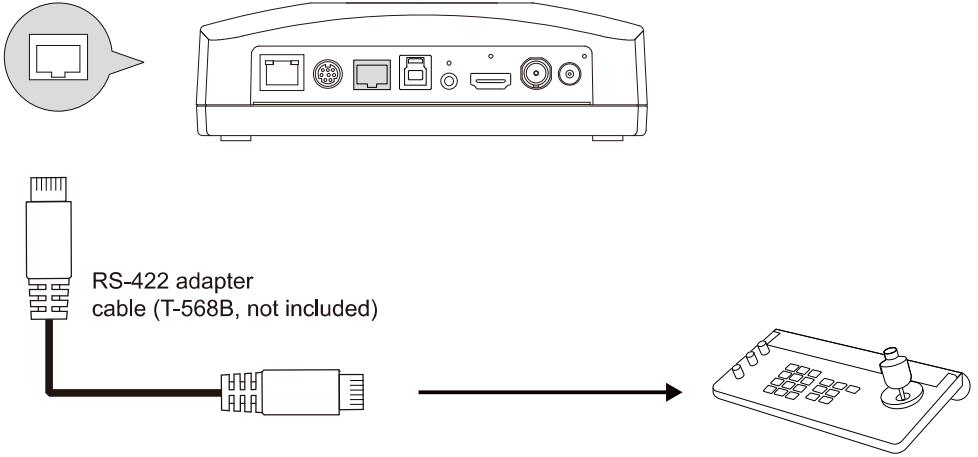

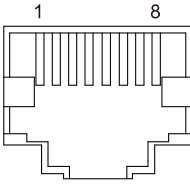

Pin #	Pin
1	TX+
2	TX-
3	RX+
4	TX+
5	TX-
6	RX-
7	RX+
8	RX-

RS-422 Port Pin Definition

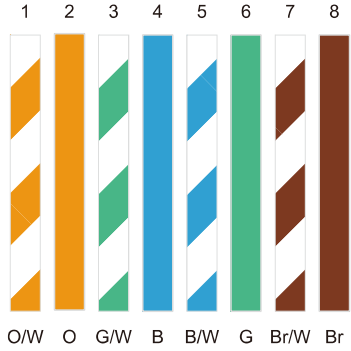

T-568B Cable

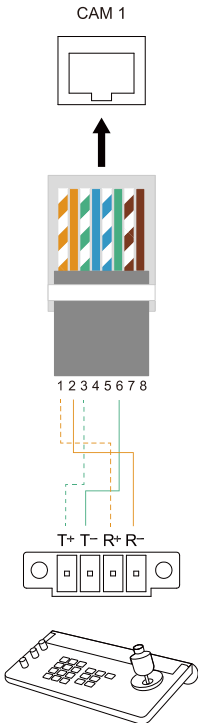

Audio Input Connection

Connect to your audio devices to receive audio.

Mic input level: 50 mVrms max.; supplied voltage: 2.5 V.

Line input level: 1 Vrms max.

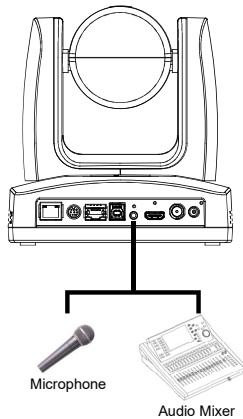

Video Output Connection

Use the included HDMI cable to connect to a monitor or TV.

Or use a 3G-SDI cable to connect to a 3G-SDI display. 3G-SDI is unavailable for model names with H.

Note:

- The camera can stream video via HDMI and 3G-SDI simultaneously.
- The OSD menu will appear by default if you make an HDMI connection before turning on the camera.

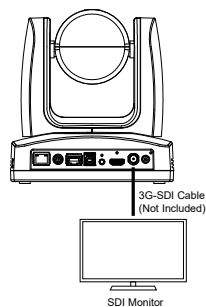
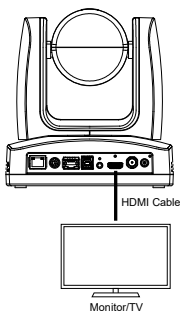

Get Started

Power the Device On and Off

The device turns on when you plug it into a power source. The device doesn't have a power button, so you must unplug the power cable to power it off.

Reset the Device

To reset the device to factory default settings, do any of the following:

OSD menu: Go to **System > Factory Default > On**.

Web interface: Go to **System > Factory Default > Reset to Factory Default**.

Factory Default Settings

IP address	DHCP
Hostname	[Model name]-[last 6 digits of MAC Address] Find the MAC address on the bottom or rear of the device.
Web interface login	None
Theme Mode	All modes reset to Standard Mode , except Zoom and Teams , which will remain unchanged.

Access the OSD Menu

During HDMI output, press the **Menu** button  on remote control to open the OSD menu.



Change Your Network Setting

Note: The camera's default network setting is DHCP.

- **Static IP**

1. Press the **MENU** button on remote control to open the OSD menu.
2. Go to **Network > DHCP > Off**.
3. Then go to **Network > Static IP**.
Select and enter **IP Address, Gateway, Mask** and **DNS** to configure.

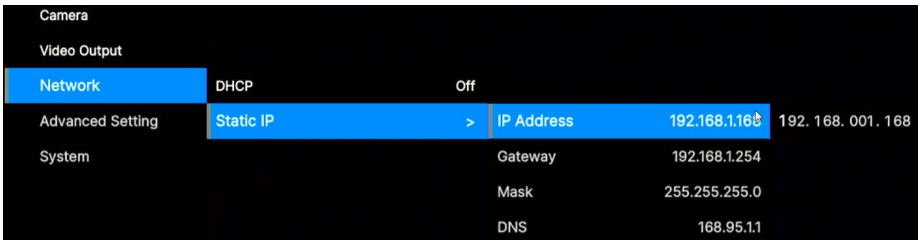

- **DHCP**

1. Press the **MENU** button on remote control to open the OSD menu.
2. Go to **Network > DHCP > On**.

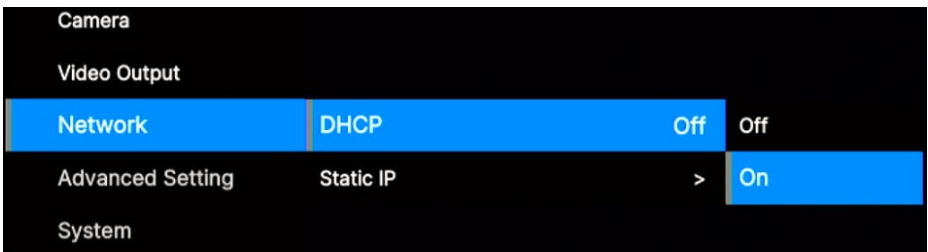

3. Then go to **System > Information** to see your camera's IP address.

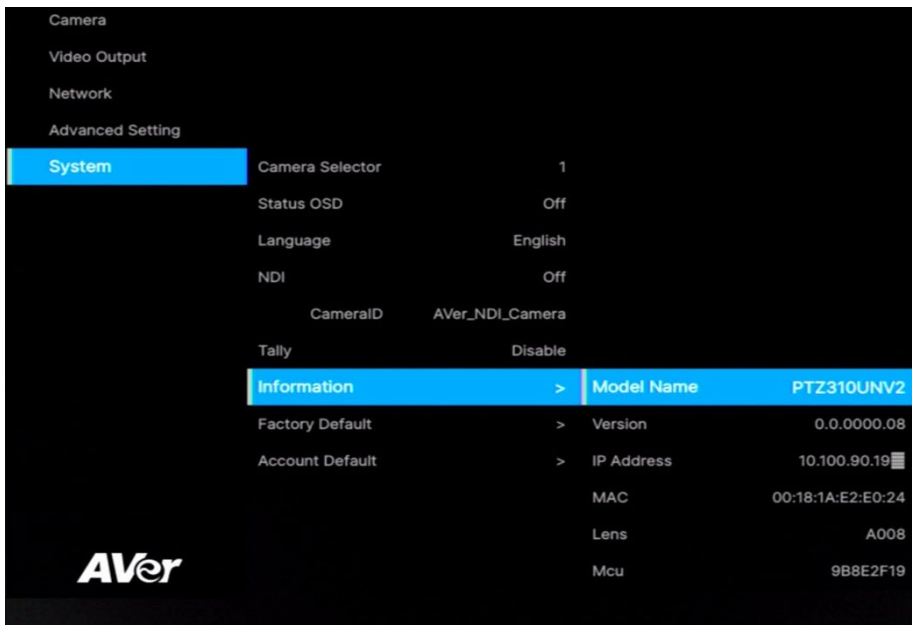

Note: If the DHCP server fails to assign an IP address after 30 seconds, the device defaults to 192.168.1.168. Multiple devices will be assigned random IPs within 192.168.1.1 - 192.168.1.254.

To troubleshoot, make sure your DHCP server is running, then disconnect and reconnect the camera LAN cable. Or go to **Network** on the OSD menu > Switch **DHCP** off and on.

OSD Menu Tree

1 st Layer	2 nd Layer	3 rd Layer	4 th Layer
Camera	Exposure Mode	Full Auto	Exposure Value
			Gain Limit Level
			Slow Shutter
		Shutter Priority	Exposure Value
			Shutter Speed
			Gain Limit Level
		Iris Priority	Exposure Value
			Iris Level
			Gain Limit Level
			Slow Shutter
		Manual	Shutter Speed
			Iris Level
	Gain Level		
	White Balance	Bright	0-31
		Auto	
		ATW	
		Indoor	
		Outdoor	
		One push	
		Manual	R Gain (0-255) B Gain (0-255)
	Pan Tilt Zoom	Preset Speed	5/25/50/100/150/200
		Digital Zoom	Off/On
		Digital Zoom Limit	
		Pan/Tilt Slow	Off/On
		Panning Direction	Default / Reverse
		Mirror	Off/On
Flip		Off/On	
Pan/Tilt Reset		Off/On	
Noise Reduction	Off/Low/Medium/High		

	Saturation	0-10	
	Contrast	0-4	
	Sharpness	0-3	
	WDR	Off/On	
	Back light compensation (BLC)	Off/On	
	LDC	Off/On	
Video Output	Theme Mode	Standard, ZOOM, Teams, NDI, Dante, Portrait (beta)	
	Frequency	50 Hz, 59.94 Hz, 60 Hz	
	Resolution	2160P/60, 2160P/59, 2160P/50, 2160P/30, 2160P/29, 2160P/25, 1080P/60, 1080P/59, 1080P/50, 1080P/30, 1080P/29, 1080P/25, 1080I/60, 1080I/59, 1080I/50, 720P/60, 720P/59, 720P/50,	
Network	DHCP	Off/On	
	Static IP	IP Address, Gateway, Mask, DNS	
Advanced Setting	Audio	Input Type	Line In
			MIC In
		Audio Volume	0-10
	Control	Serial Port	RS-232/RS-422
		Protocol	VISCA/PELCO D/PELCO P
		Camera Address	1-7
		Baud Rate	2400/4800/9600/38400
	Framing	Off/On	
SmartShoot	Off/On		
System	Camera Selector	1-3	
	Status OSD	Off/On	
	Language	English/繁體中文/日本語	
	NDI		
	Camera ID		

	Tally	Disable/Enable	
	Information	Model Name/Version/IP Address/MAC/Lens/Mcu	
	Factory Default	Off/On	
	Account Default	Off/On	

Access the Web Interface

To access the web interface of your device, you can use any of the following software to find its IP address:

- AVer Device Utility
- AVer Enterprise Management

Note: The default network setting is DHCP

AVer Device Utility

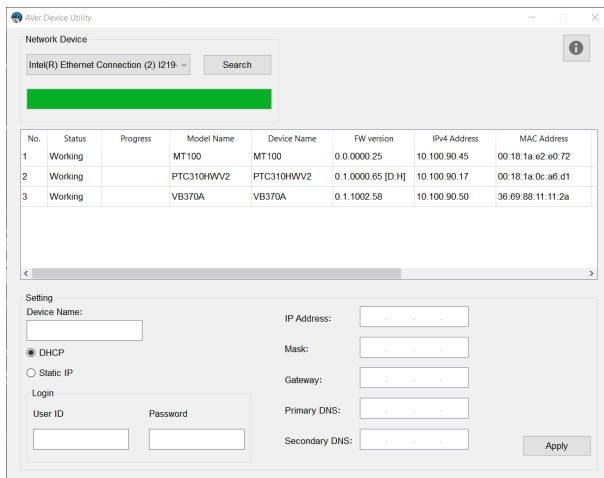

To access the web interface:

1. Download AVer Device Utility from AVer Download Center (<https://www.aver.com/download-center>) and launch the software.
2. Click **Search** to see available devices on the same local area network (LAN).

Note:

- Make sure your device is connected to the internet.
- AVer Device Utility and your device must be on the same LAN.

3. Double-click on your device's IP address in the **IPv4 Address** column to open the web interface in your browser.

To change your network to DHCP or static IP:

1. Select the checkbox of your device.

2. Enter the username and password in the **Login** field.
3. Select **DHCP** or **Static IP**, then enter your network settings if applicable in the **Settings** section.
4. Click **Apply**.

AVer Enterprise Management

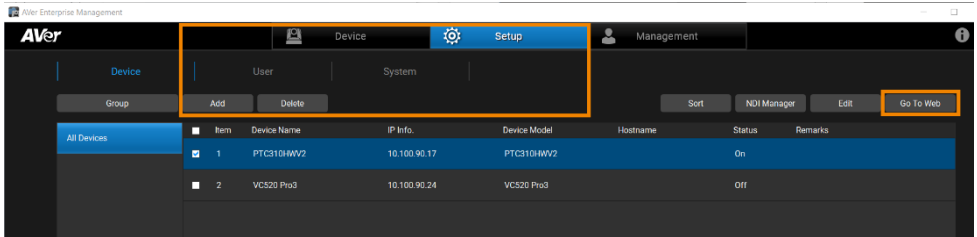

Note: The AVer Enterprise Management's default username and password is **admin/admin**.

1. Download AVer Enterprise Management from AVer Download Center (<https://www.aver.com/download-center>) and launch the software.
2. Log in with the AVer Enterprise Management's default username and password **admin/admin**.
3. Go to **Setup > Add**, then click **Auto Search** to see available devices on the same local area network (LAN).
4. Click to select your device, enter the changed username and password, then click **Save** to add the device to the device list.
5. Select the checkbox of your device, then click **Go to Web** button to open the web interface in your browser.

Log in for the First Time

When you log in for the first time, you'll be prompted to change the username and password. The username and password cannot be the same.

- Username: Use 1-32 characters.
- Password: Use 8-32 characters and a combination of uppercase letters, lowercase letters, and numbers. Symbols (!\$%'()*+,-./<=>?@[\\]^_{}~) are optional.

Web Interface

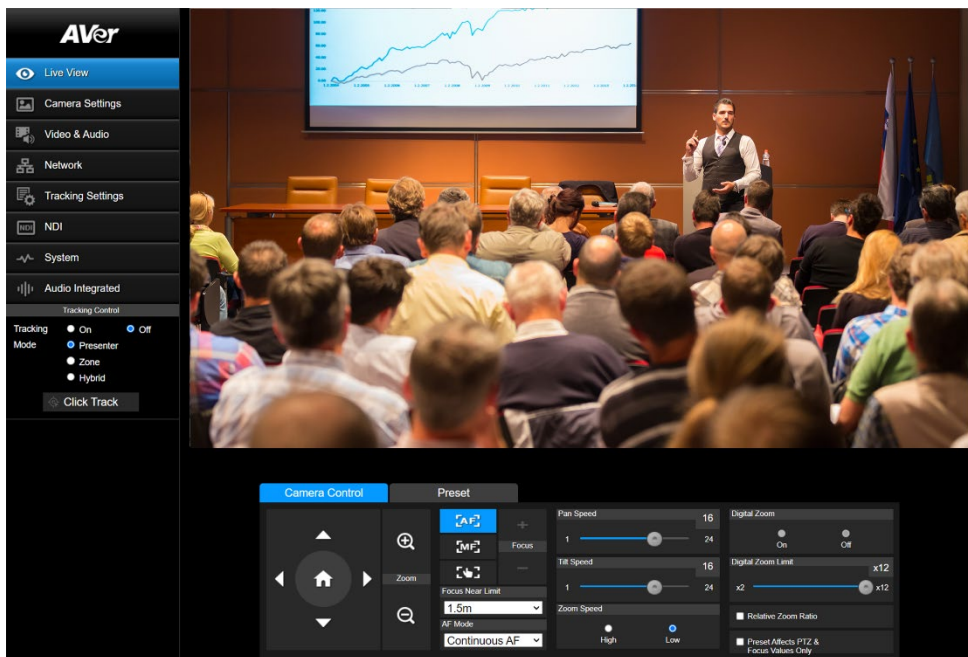

Live View

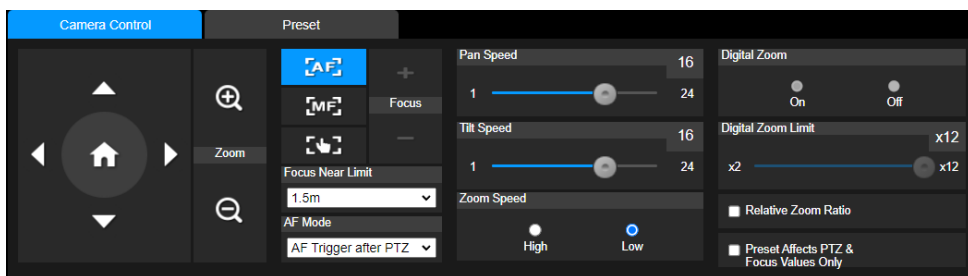

Camera Control



Item	Description
Pan, Tilt, Zoom Controls	Use pan, tilt, and zoom controls to position the camera.
Home	Reset the pan-tilt position to the center.
Auto Focus 	Focus automatically with an autofocus mode:

AF Mode	<ul style="list-style-type: none"> • AF Trigger after PTZ: Automatically focus after each pan, tilt or zoom. • Continuous AF: Automatically focus continuously.
Manual Focus 	Focus manually with + - buttons.
One Push Focus 	Focus automatically once.
Focus Near Limit	Select the nearest focus limit.
Pan Speed	Adjust pan, tilt and zoom speed.
Tilt Speed	
Zoom Speed	
Digital Zoom	Turn digital zoom on or off.
Digital Zoom Limit	Select the digital zoom limit.
Relative Zoom Ratio	Select to automatically adjust pan and tilt speeds based on the zoom ratio.
Preset Affects PTZ & Focus Values Only	<p>A preset typically includes pan, tilt, zoom, focus, and 3A (autofocus, auto exposure, auto white balance) values.</p> <p>Select to save only pan, tilt, zoom and focus values for presets.</p>

Preset

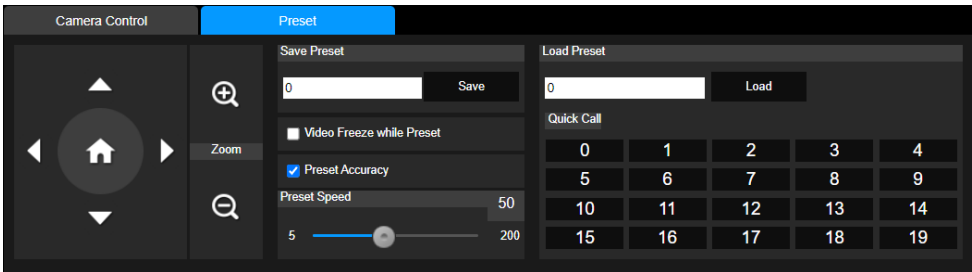

Item	Description
Save Preset	<ol style="list-style-type: none"> 1. Position the camera using pan, tilt and zoom controls. 2. Enter a preset number (0–255) in the Save Preset field and click Save.
Load Preset	<ol style="list-style-type: none"> 1. Enter a preset number (0–255) in the Load Preset field and click Load. 2. Or click a preset number (0–19) in the Quick Call section.
Video Freeze while Preset	Select to display only the live view from presets. The live view from the moving path will not be displayed.
Preset Accuracy	Select to improve the accuracy of moving to presets.
Preset Speed	Adjust the camera speed when moving to presets.
Edit Scenes	<p>To customize camera functions for preset 0–9:</p> <ol style="list-style-type: none"> 1. Click Edit Scenes.

- | | |
|--|--|
| | <ol style="list-style-type: none">2. Select Scenes 0–9 from the Scenes List to add up to 10 CGI commands.3. Select a scene from the Set Scenes drop-down list for each preset. |
|--|--|

Camera Settings

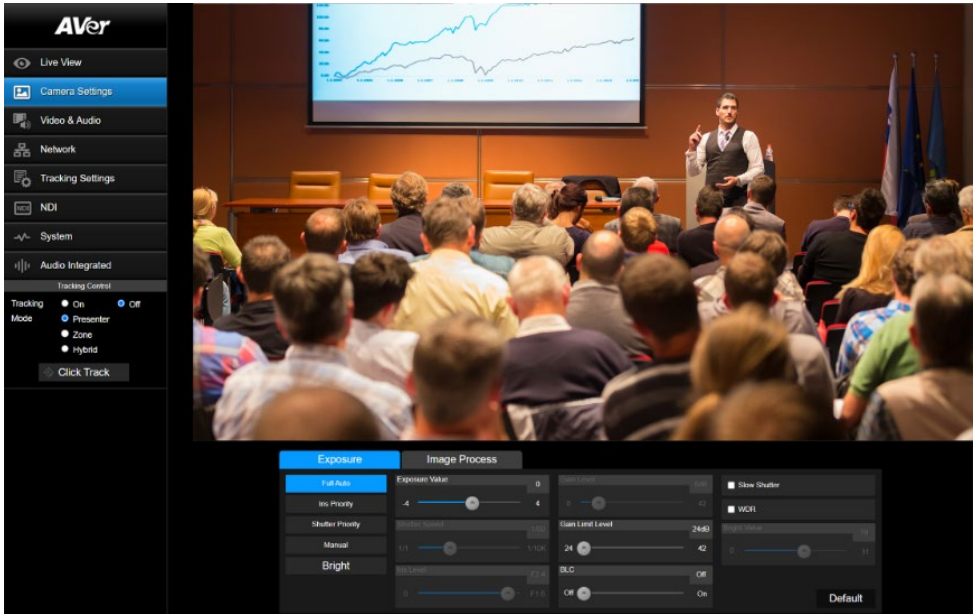

Exposure

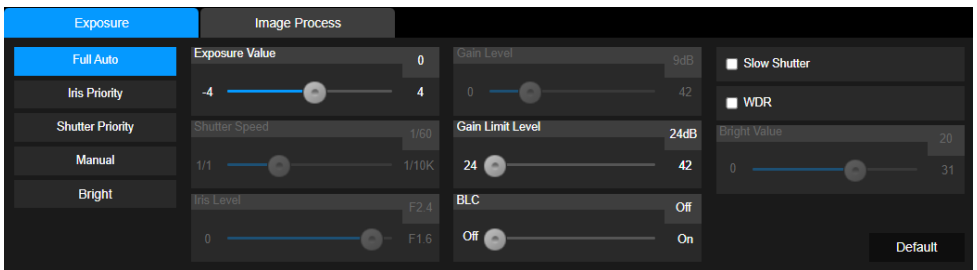

Item	Description
Exposure Mode	<p>Select an exposure mode to adjust image brightness:</p> <ul style="list-style-type: none"> Full Auto: Automatically adjusts shutter speed (ISO), iris (aperture), and gain for optimal brightness in most environments. Iris Priority: You set the iris, and the camera adjusts shutter speed and gain. Useful for controlling depth of field.

	<ul style="list-style-type: none"> ● Shutter Priority: You set the shutter speed, and the camera adjusts iris and gain. Ideal for capturing motion with minimal blur. ● Manual: Manually adjust shutter speed, iris, and gain. ● Bright: Drag the bright value slider to manually increase brightness by adjusting iris and gain.
Exposure Value	Fine-tunes overall image brightness.
Gain Limit Level	Sets the maximum gain the camera is allowed to use automatically. Helps balance between brightness and image noise.
BLC (Backlight Compensation)	Brightens subjects in front of bright backgrounds (like windows).
Slow Shutter	Makes the image brighter in low light by slowing down shutter speed. May cause motion blur.
WDR (Wide Dynamic Range)	Enhances visibility in scenes with both very bright and very dark areas so details aren't lost in shadows or highlights.
Default	Reset Exposure to factory default settings.

Image Process

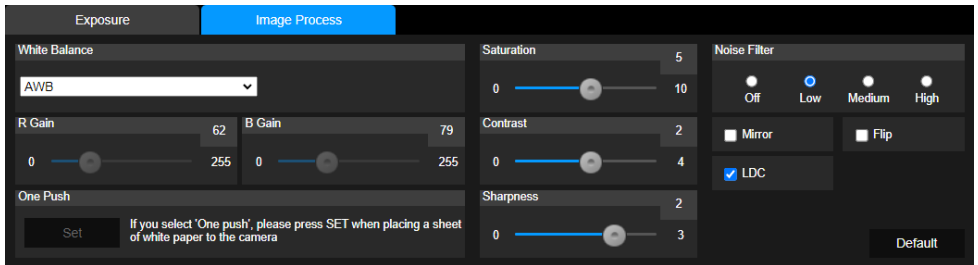

Item	Description
White Balance	<p>Select a white balance mode to match the lighting conditions and ensure accurate color:</p> <ul style="list-style-type: none"> ● AWB (Auto White Balance): Automatically adjusts white balance based on the current lighting. Best for stable indoor lighting. ● ATW (Auto Tracking White Balance): Continuously adapts to changing lighting conditions. Ideal for dynamic or mixed lighting environments. ● Indoor: Fixes red and blue gain for a color temperature of 3200 K. ● Outdoor: Fixes red and blue gain for a color temperature of 5800 K.

	<ul style="list-style-type: none"> ● One Push: Calibrates white balance using a white reference. Place a white sheet of paper in front of the lens and click Set to capture accurate color balance based on the current lighting. ● Manual: Manually adjust the red and blue gain.
Saturation	Adjust saturation, contrast and sharpness.
Contrast	
Sharpness	
Noise Filter	Select a noise filtering level.
Mirror	Flip the image horizontally.
Flip	Flip the image vertically.
LDC (30X optical zoom models only)	Correct lens distortion.
Default	Reset Image Process to factory default settings.

Video & Audio

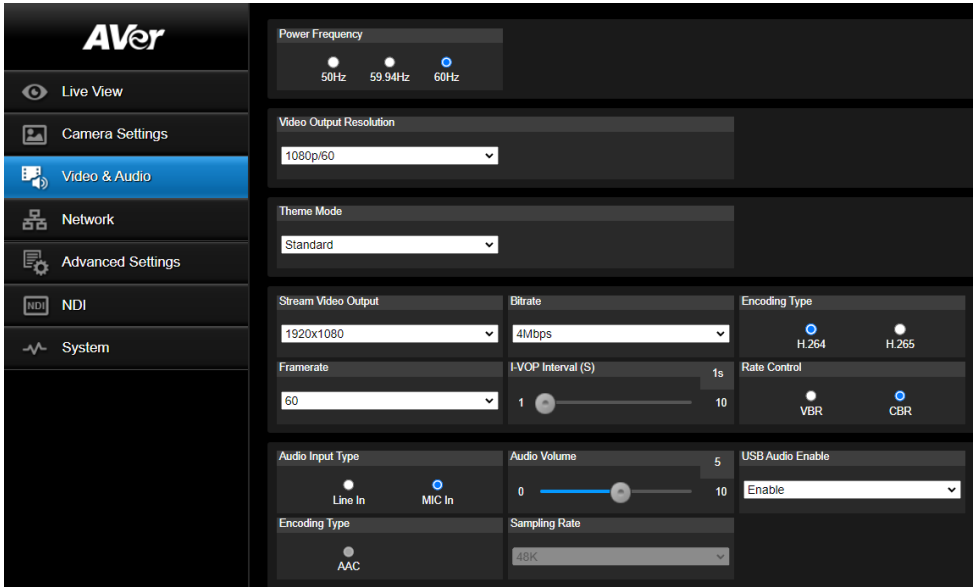

Item	Description
Power Frequency	Select 50Hz , 59.94Hz or 60Hz based on your country and region.
Video Output Resolution	Select a resolution to display on your video output device.
Theme Mode	<p>Select a video mode based on the output interface you want to use.</p> <p>Note:</p> <ul style="list-style-type: none"> For details on resolution, please refer to <Output Interface Table> . Zoom Mode: USB audio is disabled. Teams Mode: USB audio is disabled. Video is limited to USB output only. <div data-bbox="412 1193 826 1308" data-label="Image"> </div> <ul style="list-style-type: none"> When Teams Mode is selected, the camera Live View on the web interface is automatically disabled and cannot be displayed. To view the Live View, switch to another mode.

Stream Video Output	Select a stream resolution on live view from the drop-down list.
Bitrate	Select a bitrate from the drop-down list.
Encoding Type (video)	Select H.264 or H.265 to encode streaming video.
Framerate	Select a framerate for live stream – 1, 5, 15, 20 or 30 for power frequency 59.94Hz or 60Hz ; 1, 5, 15, 20 or 25 for power frequency 50Hz .
I-VOP Interval (S)	Sets how often a keyframe (or I-frame) is inserted in the video stream. <ul style="list-style-type: none"> • A keyframe is a full image frame used as a reference point in video. Shorter intervals improve video quality, but increase file size.
GOP Value (Group of Pictures Value)	Sets the number of frames between two keyframes. This controls how often keyframes are inserted in the video stream. <ul style="list-style-type: none"> • When I-VOP Interval = 0, keyframes are inserted based on the GOP Value. • When I-VOP Interval > 0, keyframes are inserted based on the set time interval, and GOP Value is ignored.
Compatibility Encoding Mode	When enabled, the camera uses Multi-Slice encoding to improve compatibility and performance when playing UHD video on certain devices. <p>Note: We recommend turning this on only if required for specific decoder compatibility. Otherwise, keep the default setting (Off).</p>
Rate Control	Select VBR or CBR .
Audio Input Type	Select to input audio by Line in or Mic in .
Audio Volume	Drag the slider to set the volume from 0 to 10 .
USB Audio Enable	Select from the drop-down list to turn on or off the setting.
Encoding Type (audio)	AAC.
Sampling Rate	48K

Output Interface Table

Mode	Video Quality	Output Interface	Comment
Standard	Standard	HDMI, SDI, IP, USB, NDI HX2	
Zoom	Zoom certified	HDMI, SDI, IP, USB, NDI HX2	The camera rotates towards the I/O ports (preset 20) when not streaming over USB. To change the sleep mode position, go to System > Sleep to Preset on the web interface.
Teams	Teams certified	USB	The camera rotates towards the I/O ports (preset 20) when not streaming over USB. To change the sleep mode position, go to System > Sleep to Preset on the web interface.

NDI	Standard	HDMI, SDI, IP, NDI HX3	
Dante	Standard	Dante	Requires a Dante license. To purchase, please visit the Dante website (https://www.getdante.com/).
Portrait (beta)	Standard	HDMI, SDI, IP, USB, NDI HX2	

Difference between NDI HX2 (Standard Mode) and NDI HX3 (NDI Mode)?

- **NDI HX3** delivers higher quality, lower latency video and audio over HX2. To be certified, HX3 devices need to support low latency, constant bitrate (CBR) encoding, and meet stricter demands such as keyframe response times and a fixed GOP size.
- **NDI HX2** devices follow a more relaxed set of requirements. These devices may have slower latency or keyframe or a larger GOP.

Note: For detailed technical requirements, please refer to the NDI documentation (<https://docs.ndi.video/all/developing-with-ndi/ndi-certified/certification-guidelines/technical-requirements>).

Network

AVer

- 👁️ Live View
- 📷 Camera Settings
- 🔊 Video & Audio
- 🌐 Network
- ⚙️ Tracking Settings
- NDI NDI
- 📶 System
- 🔊 Audio Integrated

Tracking Control

Tracking On Off

Mode Presenter Zone Hybrid

Click Track

DHCP

On Off

IP Address: 192.168.1.110

Gateway: 192.168.1.254

Hostname

PTZ310UNV2

Network: 192.168.1.5

DNS: 192.168.1.5

NTP

On Off

NTP Server: pool.ntp.org

Confirm

RTMP Settings

Server URL

Stream Key

Start Stream STOP

RTSP Security

On Off

RTSP Audio Enable

On Off

HLS Settings

Stream URL

Start Stream STOP

SRT Settings

Destination IP: 192.168.31.166 Port: 5000 Encryption: None

Latency: 1000 ms Passphrase:

Connect Status: Disconnected

Start Stream STOP

HTTPS

Only On Off

Upload Certificate

Choose File No file chosen Upload

Cert Status: None

SSH

On Off

Visca Port Mode

Default

Visca Port Number

Port: 2201 Save

802.1X Enable

On Off

Eap Method

MD5 TLS PEAP

Eap Setting

Identity: Password:

Client Certificate

Choose File No file chosen Upload Private Key Password:

CA Certificate

Choose File No file chosen Upload Confirm

FreeD

On Off

Camera ID

103

IP Address: 192.168.1.100 Port: 40000

Plan Backlash: Filter Backlash:

Confirm

Item	Description
DHCP	Set up the network to DHCP or Static IP. <ul style="list-style-type: none"> ● DHCP: Select On to assign the related IP settings with the camera automatically. Click Confirm to save the settings. ● Static IP: Select Off to manually enter the IP Address, Netmask, Gateway and DNS. Click Confirm to save the settings.
Hostname	Enter a hostname that is displayed on devices such as an IP router. <ul style="list-style-type: none"> ● The default hostname is [Model name]-[last 6 digits of MAC Address].
NTP	Turn Network Time Protocol (NTP) on or off.
RTMP Settings	Stream camera live video to a video platform such as YouTube. <ol style="list-style-type: none"> 1. Enter the Server URL and Stream Key of the platform. Please refer to the instruction of the platform you use to obtain the server URL and stream key. 2. Click Start Stream to start streaming, Stop to stop streaming.
RTSP Security	Protect your video stream on media players such as VLC, PotPlayer and QuickTime by ensuring that only authorized users can access it. <ul style="list-style-type: none"> ● When Security is turned off: <ol style="list-style-type: none"> 1. Enter your camera's RTSP URL into the media player. 2. RTSP URL: rtsp://[camera IP address]/live_st1 Example: rtsp://192.168.1.100/live_st1 ● When Security is turned on: <ol style="list-style-type: none"> 1. Enter your camera's RTSP URL, username and password into the media player. 2. RTSP URL: rtsp://[username:password]@[camera IP address]/live_st1 Example: rtsp://1:1@192.168.1.100/live_st1 3. Username and password: camera's web interface login.
HLS Settings	Configure HTTP Live Streaming (HLS) settings to provide adaptive bitrate streaming, which ensures smooth playback and minimizes buffering. <ol style="list-style-type: none"> 1. Enter the stream URL obtained from the streaming service or server. 2. Click Start Stream to start streaming, Stop to stop streaming.
SRT Settings	<ul style="list-style-type: none"> ● vMix <ol style="list-style-type: none"> 1. Make sure the vMix workstation and your camera are on same network. Copy the workstation's IP address.

```

C:\WINDOWS\system32\cmd.exe
Windows IP Configuration

Wireless LAN adapter Local Area Connection* 1:
   Media State . . . . . : Media disconnected
   Connection-specific DNS Suffix  . :
Ethernet adapter Ethernet:
   Connection-specific DNS Suffix  . :
   Link-local IPv6 Address . . . . . : fe80::8013:bd79:8b8c:2339%21
   IPv4 Address. . . . . : 192.168.1.10
   Subnet Mask . . . . . : 255.255.255.0
   Default Gateway . . . . . :
Wireless LAN adapter Wi-Fi:
   Connection-specific DNS Suffix  . : aver.com
   Link-local IPv6 Address . . . . . : fe80::6854:e9c7:1f95:a46e%11
   IPv4 Address. . . . . : 10.100.200.67
   Subnet Mask . . . . . : 255.255.255.0
   Default Gateway . . . . . : 10.100.200.254
Ethernet adapter Bluetooth Network Connection:

```

2. Go to **Stream** tab > select **SRT (Listener)** from the **Stream Type** drop-down list. Copy the **Port** value.

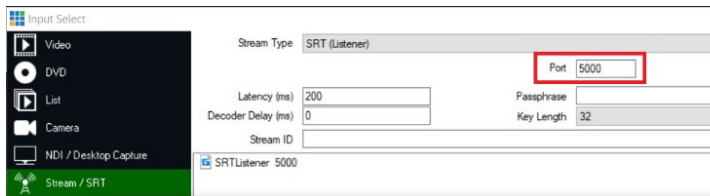

3. Paste the IP address and Port value into **SRT Settings** fields and click **Start Stream**. **Connect Status** will change to **Connected**.

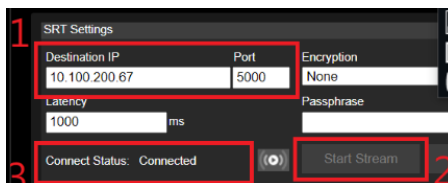

- **OBS (Open Broadcaster Software)**
 1. Make sure the OBS workstation and your camera are on same network. Copy the workstation's IP address.

```

Connection-specific DNS Suffix . : aver.com
Link-local IPv6 Address . . . . . : fe80::f1dc:b0da:87bd:ac1e%1
IPv4 Address. . . . . : 10.100.105.127
Subnet Mask . . . . . : 255.255.255.0
Default Gateway . . . . . : 10.100.105.254

```

2. Open OBS. Add a scene and a source.
3. Enter "srt://[Workstation IP]:[port]?mode=listener" in the **Input** field.
Example: srt://10.100.105.127:8889?mode=listener

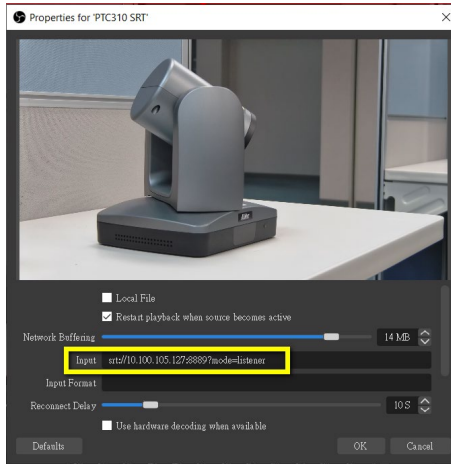

4. If there is no image, right-click on the source > **Transform > Fit to screen** to re-scale image.

HTTPS	<p>Enable HTTPS to establish a secure connection between your browser and your camera. To enable HTTPS access on your camera:</p> <ol style="list-style-type: none"> 1. Obtain a SSL certificate for encryption and decryption in base-64 encoded format and use a private key in PKCS#8 format (unencrypted). 2. Package the required certificate content into PEM format. The SSL certificate uploaded to the camera must be in PEM format. 3. Click Choose File to select the certificate file, and then click Upload. 4. Turn on HTTPS.
SSHD	Turn remote debugging from AVer on or off.
Visca Port Mode	Select a VISCA port mode, then enter the Visca Port Number .
802.1x Enable	Turn 802.1x Enable on or off.
Eap Method	When 802.1x Enable is turned on, select an Eap method.
Eap Setting	Based on your Eap method, complete the authentication and click Confirm .
FreeD	<p>Turn the FreeD protocol on to send camera positioning data to a virtual reality production system.</p> <p>When FreeD is turned on, enter the following information:</p> <ul style="list-style-type: none"> ● Your Camera ID. ● The IP Address and Port of the device receiving your camera's positioning data. ● Manually enter pan and tilt backlash amount to ensure accurate aiming.

Advanced Settings

SmartShoot

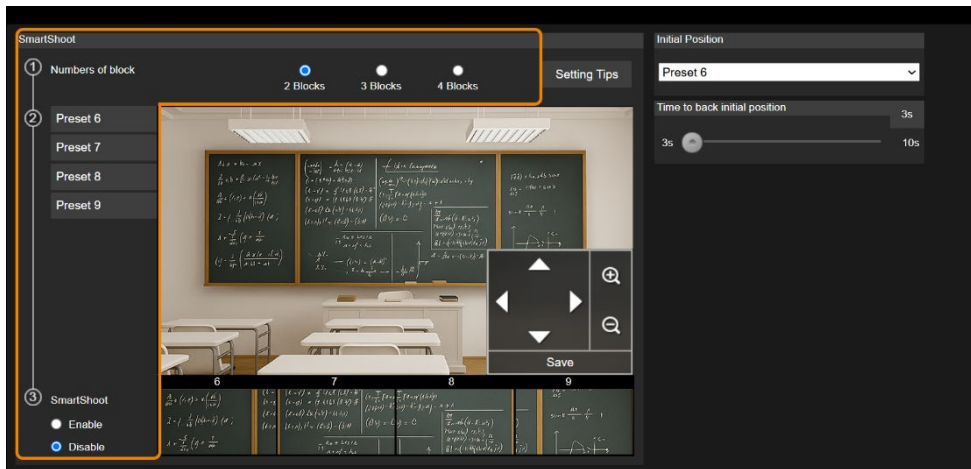

SmartShoot uses up to 4 presets to frame and follow the presenter on screen.

When no one is in the presets, the camera returns to the Initial Position (Preset 6 or selected preset).

Note: SmartShoot detects human heads or silhouettes entering the presets. Beside the presenter, make sure there are no other human heads or silhouettes on a poster in the presets to avoid interference.

To set up SmartShoot:

1. Go to **Advanced Settings** > select the **Number of blocks** (presets) you want to track.
2. Select the preset you want to save. Presets 6–9 are available.

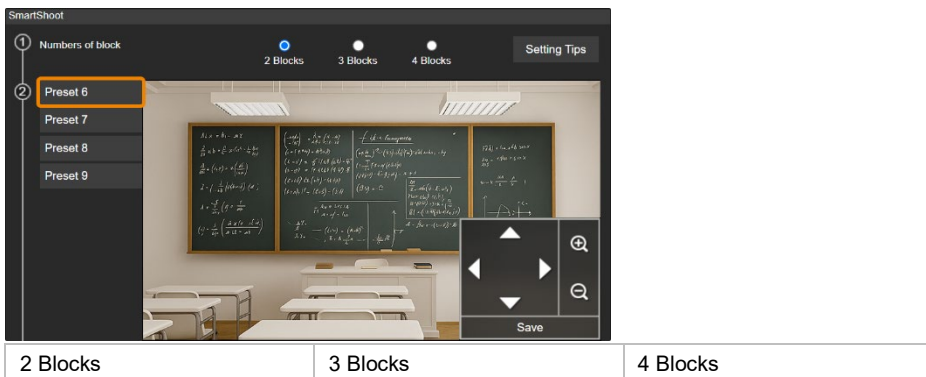

- Use pan, tilt and zoom controls to position your camera and click **Save** to save that position. A thumbnail will appear in the preview. Repeat these steps for all presets.

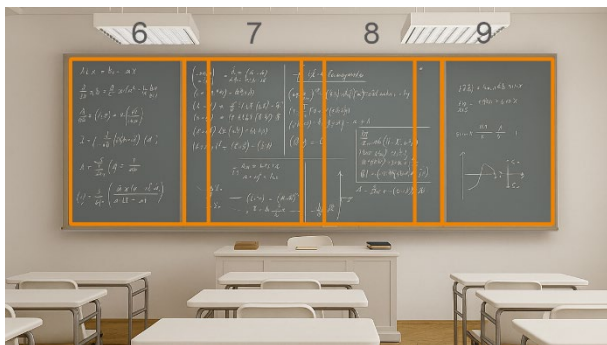

Note: Define overlapping presets for a smooth transition. When the presenter exits the previous preset, the camera will follow and move to the next preset.

- Configure additional settings:

Item	Description
Initial Position	If no one is in the presets, the camera returns to the Initial Position (Preset 6 or selected preset). <div data-bbox="448 879 943 999" style="background-color: #333; color: white; padding: 10px; margin-top: 10px;"> Initial Position <input style="width: 100%; background-color: white; color: black; border: none;" type="text" value="Preset 6"/> </div>
Time to go back to initial position	Drag the slider to set a delay time before the camera returns to the Initial Position.

- Turn on SmartShoot by selecting **Enable**.
Or open the OSD menu with the remote control, go to **Advanced Settings > SmartShoot > On**.

Framing

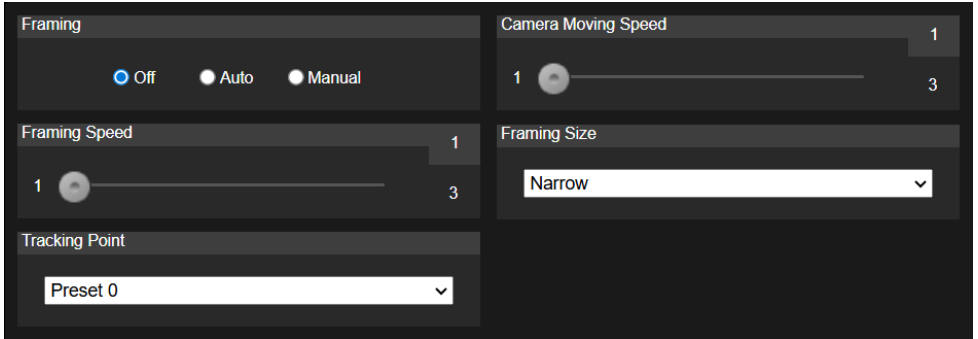

Auto Framing frames entire group on screen automatically while Manual Framing frames entire group on screen once.

When no one is on screen, the camera returns to the pan-tilt center (default) or the Tracking Point (optional, selected preset).

To set up Framing:

1. Go to **Advanced Settings**.
2. Configure additional settings:

Item	Description
Framing Speed	The camera auto frames every time a subject enters or leaves the screen. If Auto Framing feels too frequent, drag the slider to adjust the trigger speed: 1 = Slow, 3 = Fast .
Tracking Point	<p>When no one is on screen, the camera returns to the pan-tilt center (default) or the Tracking Point (optional, selected preset).</p> <p>To select a Tracking Point, make sure you have defined the required preset.</p> <div style="border: 1px solid black; background-color: #333; color: white; padding: 5px; margin: 10px 0;"> <p>Tracking Point</p> <p>Preset 0 ▾</p> </div>
Camera Moving Speed	Drag the slider to adjust pan, tilt, and zoom speed: 1 = Slow, 3 = Fast .

Framing Size	Select a framing size to include or remove excess space on either side of the subject.
--------------	--

3. Turn on Framing by selecting **Auto** or **Manual**.

Note: After Manual Framing once, Framing remains turned on but inactive. To Manual Framing again, press and hold **Enter** on the remote control.

NDI

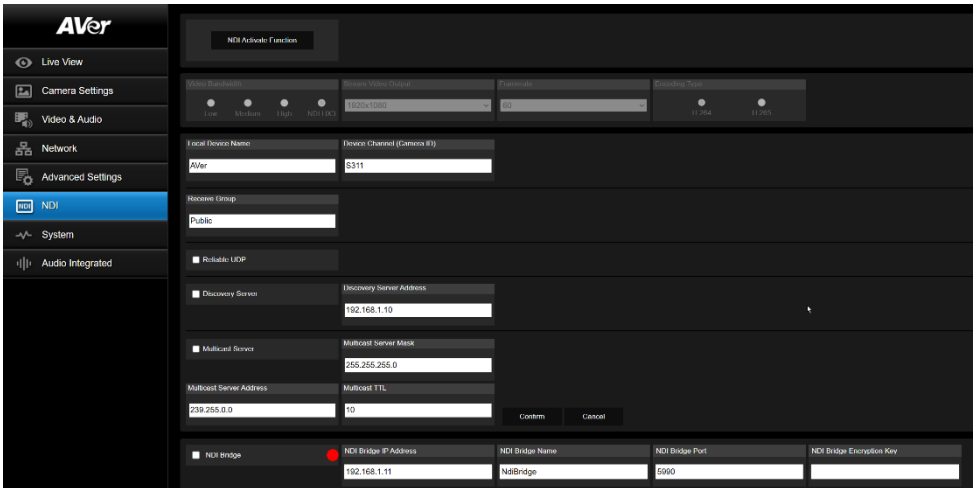

Item	Description									
Built-in NDI	Upgrade to the latest firmware to enable NDI at no additional cost.									
Video Bandwidth	<p>Select a bandwidth.</p> <ul style="list-style-type: none"> In NDI HX3 Mode, framerate adjustment is restricted as per certification guidelines. It is possible with other bandwidths (Low, Medium, High). The main difference between High and NDI HX3 Modes lies in the compression settings. <table border="1" data-bbox="453 1061 1024 1220"> <thead> <tr> <th>Parameter</th> <th>High</th> <th>HX3</th> </tr> </thead> <tbody> <tr> <td>Bitrate</td> <td>~64 Mbps</td> <td>~ 90 Mbps</td> </tr> <tr> <td>GOP Value</td> <td>1 second (adjustable when I-VOP Interval = 0)</td> <td>20 frames (non-adjustable)</td> </tr> </tbody> </table>	Parameter	High	HX3	Bitrate	~64 Mbps	~ 90 Mbps	GOP Value	1 second (adjustable when I-VOP Interval = 0)	20 frames (non-adjustable)
Parameter	High	HX3								
Bitrate	~64 Mbps	~ 90 Mbps								
GOP Value	1 second (adjustable when I-VOP Interval = 0)	20 frames (non-adjustable)								
Stream Video Output	Choose a streaming output resolution for the live view. 4K (2160p) is available for model names with U only.									
Framerate	Choose a framerate.									
Encoding Type	Select H.264 or H.265 .									
Local Device Name	<p>Enter a name that identifies your camera group on the NDI software.</p> <ul style="list-style-type: none"> The default is AVer. 									

Device Channel (Camera ID)	<p>Enter a name that identifies your camera on the NDI software.</p> <ul style="list-style-type: none"> • The default is your model name. • A name must have no more than 10 characters. Use number, upper and lower case letter, or special character (! @ % ^ , . / : + ? [] { } - _ ~).
Receive Group	<p>Enter a name for a receive group.</p> <ul style="list-style-type: none"> • All devices in the receive group receive the same NDI streams. • The receive group should remain public. If this is changed, you will need to join the group through NDI® Access Manager.
Reliable UDP	Select the checkbox to enable Reliable User Datagram Protocol (RUDP).
Discovery Server	Select the checkbox to enable discovery server to allow devices to discover and connect to each other on a network automatically.
Discovery Server Address	Enter the IP address of a server running a discovery server application.
Multicast Server	Select the checkbox to enable multicast server to allow efficient distribution of NDI streams to multiple receivers without overwhelming the network.
Multicast Server Mask	Enter the network mask to specify the range of IP addresses that are eligible to receive NDI streams.
Multicast Server Address	Enter the IP address of a group of recipients that receive NDI streams from a multicast server.
Multicast TTL	Enter a multicast time to live (TTL) value between 1-255 to control the distance multicast packets can travel.
NDI Bridge	Connects and shares NDI streams between remote NDI-enabled devices and infrastructures across a wide area networks (WAN). Requires the NDI Tools from NewTek (https://ndi.video/tools/).

System

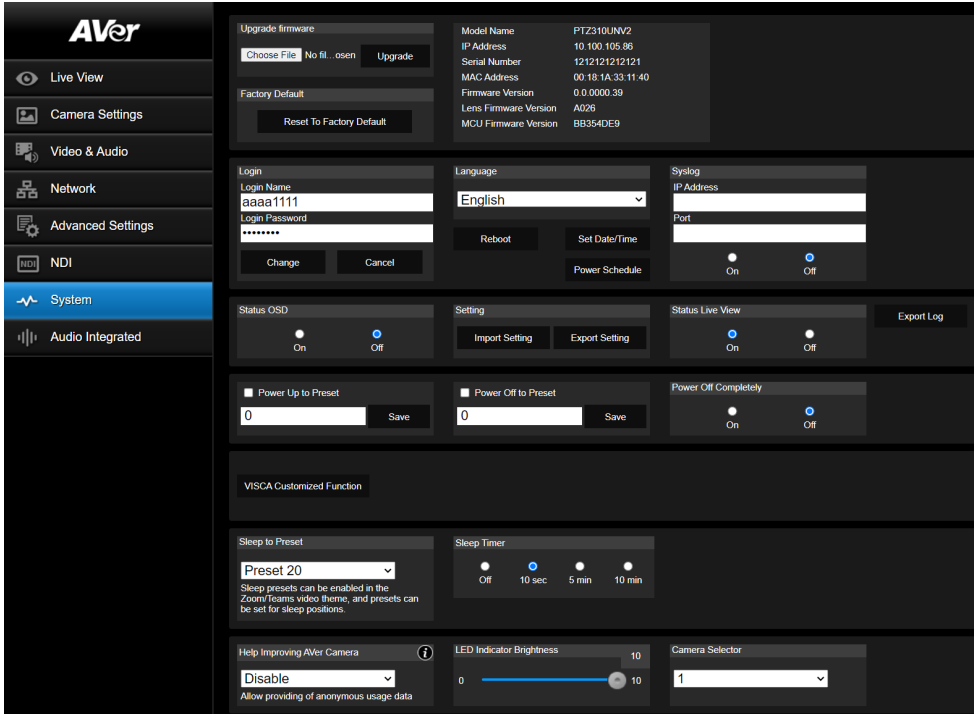

Item	Description
Upgrade Firmware	<p>To upgrade the firmware:</p> <ol style="list-style-type: none"> 1. Download the latest firmware from AVer Download Center (https://www.aver.com/download-center). 2. On the web interface, go to System > Upgrade firmware. 3. Click Browse to select the firmware. 4. Click Upgrade. 5. Refresh the browser after the upgrade is complete. <p>Note: Keep your camera connected to a power source during firmware upgrade. Network connection will be lost during the process and camera will reboot automatically after upgrading.</p>
Factory Default	Reset the camera to factory default settings.
Login	Change the web interface login.
Language	Change the web interface language.
Reboot	Restart your camera.
Set Date/Time	Set the camera date and time.

Power Schedule	Schedule specific times for the camera to reboot or shut down.
Syslog	Turn on to receive technical supports. Enter the IP Address and Port of the receiving device for debug and problem analysis.
Status OSD	Turn on to display preset, zoom ratio, SmartShoot and Framing captions on HDMI output.
Setting	Export or import your camera settings
Status Live View	Turn the camera live view on or off.
Export Log	Export system log.
Power Up to Preset	Move the camera to the defined preset after powering on. To enable: 1. Make sure the preset has been defined. 2. Select Power Up to Preset > enter a preset number > click Save .
Power Off to Preset	Move the camera to the defined preset before powering off. To enable: 1. Make sure the preset has been defined. 2. Select Power Off to Preset > enter a preset number > click Save .
VISCA Customized Function	Set VISCA customized functions and click OK .
Sleep to Preset	Set up to move the camera to a preset after a delay time, when you are not streaming video on Zoom/Teams over USB for enhanced privacy. ● To enable: 1. Make sure you have defined the selected preset. 2. Go to Video & Audio > Theme Mode > select Zoom or Teams . 3. Go to Systems > Sleep to Preset > select a preset or use the default (preset 20, towards I/O ports). 4. Go to Systems > Sleep Timer > select a delay time.
Sleep Timer	● To disable, select Off from the Sleep to Preset drop-down list.
Help Improving AVer Camera	Opt-in or opt-out of providing anonymous usage data.
LED Indicator Brightness	Drag the slider to adjust the brightness.
Camera Selector	Assign a camera select button 1-3 on the remote control to the camera. ● Both camera and remote control have been set to 1 at the factory.
P/T Reset	Reset the pan-tilt position to the center.
Panning Direction	Invert or reset the pan direction.

Audio Integrated

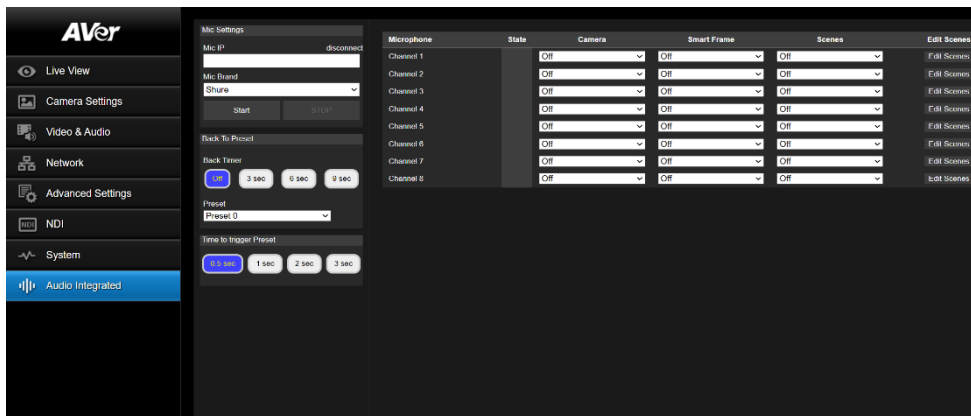

Supported Microphones

Shure® MXA910 Ceiling Array Microphone

Shure® MXA920-S / MXA920-R Ceiling Array Microphone

Item	Description
Mic Settings	Enter the microphone IP t to connect. Click Start to connect and Stop to disconnect.
Back to Preset	Select a delay time before the camera moves to the selected preset.
Time to trigger Preset	Select a delay time before the camera moves to the preset when the microphone detects sound.
Mic Manager	<ul style="list-style-type: none"> ● Pair microphone channels with presets. ● Turn tracking on or off for each channel. ● Customize camera functions and add up to 10 CGI commands for each channel.

Appendix

VISCA RS-232 Commands

Command Set	Command	Command Packet	Comments
CAM_Power	On	8x 01 04 00 02 FF	Power ON/OFF
	Off	8x 01 04 00 03 FF	
CAM_Zoom	Stop	8x 01 04 07 00 FF	p=0 (Low) to 7 (High)
	Tele(Variable)	8x 01 04 07 2p FF	
	Wide(Variable)	8x 01 04 07 3p FF	
	Direct	8x 01 04 47 0p 0q 0r 0s FF	pqrs: Zoom Position , PTC310: 0x0000~0x6f20 PTC330: 0x0110~0x5490
CAM_Focus	Stop	8x 01 04 08 00 FF	Each 'Far/Near' needs a 'stop'
	Far (Standard)	8x 01 04 08 02 FF	
	Near (Standard)	8x 01 04 08 03 FF	
	Auto Focus	8x 01 04 38 02 FF	
	Manual Focus	8x 01 04 38 03 FF	
	One Push	8x 01 04 18 01 FF	
	Direct	8x 01 04 47 0p 0q 0r 0s FF	pqrs: Zoom Position
CAM_WB	Auto	8x 01 04 35 00 FF	Normal Auto
	ATW	8x 01 04 35 04 FF	
	Indoor	8x 01 04 35 01 FF	
	Outdoor	8x 01 04 35 02 FF	
	One Push WB	8x 01 04 35 03 FF	One Push WB mode
	Manual	8x 01 04 35 05 FF	Manual Control mode
	One Push	8x 01 04 10 05 FF	One Push WB Trigger
CAM_RGain	Up	8x 01 04 03 02 FF	Manual Control of R Gain
	Down	8x 01 04 03 03 FF	
CAM_Bgain	Up	8x 01 04 04 02 FF	Manual Control of B Gain
	Down	8x 01 04 04 03 FF	
CAM_AE	Full Auto	8x 01 04 39 00 FF	Automatic Exposure mode
	Manual	8x 01 04 39 03 FF	Manual Control mode
	Shutter Priority	8x 01 04 39 0A FF	Shutter Priority Automatic Exposure mode
	Iris Priority	8x 01 04 39 0B FF	Iris Priority Automatic Exposure mode

	Bright	8x 01 04 39 0D FF	Bright Mode (Manual control)
CAM_Shutter	Up	8x 01 04 0A 02 FF	Shutter Setting
	Down	8x 01 04 0A 03 FF	
CAM_Iris	Up	8x 01 04 0B 02 FF	Iris Setting
	Down	8x 01 04 0B 03 FF	
CAM_Gain	Up	8x 01 04 0C 02 FF	Gain Setting
	Down	8x 01 04 0C 03 FF	
CAM_Bright	Up	8x 01 04 0D 02 FF	Bright Setting
	Down	8x 01 04 0D 03 FF	
CAM_Exposure Comp.	Up	8x 01 04 0E 02 FF	Exposure Compensation Amount Setting
	Down	8x 01 04 0E 03 FF	
CAM_Backlight	On	8x 01 04 33 02 FF	Back Light Compensation ON/OFF
	Off	8x 01 04 33 03 FF	
CAM_Preset	Reset	8x 01 04 3F 00 pp FF	pp: Preset Number 0x00~0xFF
	Set	8x 01 04 3F 01 pp FF	
	Recall	8x 01 04 3F 02 pp FF	
CAM_Menu	On/Off	8x 01 06 06 10 FF	Display ON/OFF
Pan-tilt Drive	Up	8x 01 06 01 VV WW 03 01 FF	VV: Pan speed setting 0x01 (low speed) to 0x18 (high speed) WW: Tilt speed setting 0x01 (low speed) to 0x18 (high speed)
	Down	8x 01 06 01 VV WW 03 02 FF	
	Left	8x 01 06 01 VV WW 01 03 FF	
	Right	8x 01 06 01 VV WW 02 03 FF	
	UpLeft	8x 01 06 01 VV WW 01 01 FF	
	UpRight	8x 01 06 01 VV WW 02 01 FF	
	DownLeft	8x 01 06 01 VV WW 01 02 FF	
	DownRight	8x 01 06 01 VV WW 02 02 FF	
	Stop	8x 01 06 01 VV WW 03 03 FF	
	Home	8x 01 06 04 FF	
	Reset	8x 01 06 05 FF	
CAM_WDR	On	8x 01 04 3D 02 FF	Wdr ON/OFF
	Off	8x 01 04 3D 03 FF	
CAM_MenuEnter		8x 01 7E 01 02 00 01 FF	Enter Submenu
Tally Lamp	ON (Red)	8x 01 7E 01 0A 00 02 FF	
	OFF	8x 01 7E 01 0A 00 03 FF	
	ON (Green)	8x 01 7E 01 0A 00 04 FF	

	ON (Amber)	8x 01 7E 01 0A 00 05 FF	
Freeze	Freeze On	81 01 04 62 02 FF	Freeze On Immediately
	Freeze Off	81 01 04 62 03 FF	Freeze Off Immediately
	Preset Freeze On	81 01 04 62 22 FF	Freeze On When Running Preset
	Preset Freeze Off	81 01 04 62 23 FF	Freeze Off When Running Preset
CAM_Memory Special	Set	8x 01 04 3F 01 pp FF	<p>These are changeable depending on VISCA Customized Functions web setting:</p> <p>pp: 0x00 To 0xFF normal preset</p> <p>pp: 0x5F => Trun on OSD menu</p> <p>pp: 0xA0 => Full Body</p> <p>pp: 0xA1 => Upper Body</p> <p>pp: 0xA2 => Tracking Point</p> <p>pp: 0xA3 => Switch</p> <p>pp: 0xA4 => Presenter mode (supported in FW v25 or newer)</p> <p>pp: 0xA5 => Zone mode (supported in FW v25 or newer)</p> <p>pp: 0xA6 => Hybrid mode (supported in FW v35 or newer)</p> <p>pp: 0x5A => Framing Enable</p> <p>pp: 0x5B => Framing Disable</p> <p>pp: 0x5C => Framing Trigger</p> <p>pp: 0x5D => SmartShoot Enable</p> <p>pp: 0x5E => SmartShoot Disable</p>
Absolute Position	Set	8x 01 06 02 VV WW 0Y 0Y 0Y 0Y 0Z 0Z 0Z 0Z FF	<p>VV: Pan speed setting 0x01 (low speed) to 0x18 (high speed)</p> <p>WW: Tilt speed setting 0x01 (low speed) to 0x18 (high speed)</p> <p>YYYY: Pan Position</p> <p>ZZZZ: Tilt Position</p>

RTMP	On	8x 01 04 A2 02 FF	
	Off	8x 01 04 A2 03 FF	
Theme mode	Standard	8x 01 04 A3 00 FF	
	ZOOM	8x 01 04 A3 01 FF	
	Teams	8x 01 04 A3 02 FF	
	NDI	8x 01 04 A3 03 FF	
	Portrait	8x 01 04 A3 04 FF	
	Dante	Pending	
Reboot	On	8x 01 04 A4 FF	
Preset Affects PTZ & Focus Values Only	On	8x 01 04 A5 02 FF	
	Off	8x 01 04 A5 03 FF	
Relative Zoom Ratio	On	8x 01 04 A6 02 FF	
	Off	8x 01 04 A6 03 FF	

Inquiry Command	Command Packet	Reply Command Packet	Comments
CAM_PowerInq	8x 09 04 00 FF	y0 50 02 FF	On
		y0 50 03 FF	Off
CAM_WBModelInq	8x 09 04 35 FF	y0 50 00 FF	Auto
		y0 50 01 FF	In Door
		y0 50 02 FF	Out Door
		y0 50 03 FF	One Push WB
		y0 50 04 FF	ATW
		y0 50 05 FF	Manual
CAM_RGainInq	8x 09 04 43 FF	y0 50 00 00 0p 0q FF	pq: R Gain
CAM_BGainInq	8x 09 04 44 FF	y0 50 00 00 0p 0q FF	pq: B Gain
CAM_AEModelInq	8x 09 04 39 FF	y0 50 00 FF	Full Auto
		y0 50 03 FF	Manual
		y0 50 0A FF	Shutter Priority
		y0 50 0B FF	Iris Priority
		y0 50 0D FF	Bright
CAM_ShutterPosInq	8x 09 04 4A FF	y0 50 00 00 0p 0q FF	pq: Shutter Position
CAM_IrisPosInq	8x 09 04 4B FF	y0 50 00 00 0p 0q FF	pq: Iris Position
CAM_GainPosInq	8x 09 04 4C FF	y0 50 00 00 0p 0q FF	pq: Gain Position
CAM_BrightPosInq	8x 09 04 4D FF	y0 50 00 00 0p 0q FF	pq: Bright Position
CAM_ExpCompPosInq	8x 09 04 4E FF	y0 50 00 00 0p 0q FF	pq: ExpComp Position
CAM_FocusModelInq	8x 09 04 38 FF	y0 50 02 FF	Auto Focus
		y0 50 03 FF	Manual Focus
CAM_FocusPosInq	8x 09 04 48 FF	y0 50 0p 0q 0r 0s FF	pqrs: Focus Position
zoom_Pos_Inq	8x 09 04 47 FF	y0 50 0p 0q 0r 0s FF	pqrs: Zoom Position
PT_Pos_Inq	8x 09 06 12 FF	y0 50 0Y 0Y 0Y 0Y 0Z 0Z 0Z 0Z FF	YYYY: Pan Position ZZZZ: Tilt Position
CAM_Preset Inq	8x 09 04 3F FF	y0 50 pp FF	Return the last preset number which has been operated pp:01-FF
CAM_OSD MENU on/off	8x 09 7E 04 76 01 FF	y0 50 02 FF	On
		y0 50 03 FF	Off
CAM_Tally	8x 09 7E 01 0A FF	y0 50 02 FF	On
		y0 50 03 FF	Off
CAM_WDR mode	8x 09 04 3D FF	y0 50 02 FF	On

		y0 50 03 FF	Off
CAM_BLC mode	8x 09 04 33 FF	y0 50 02 FF	On
		y0 50 03 FF	Off
CAM_Live Freeze	8x 09 04 62 01 FF	y0 50 02 FF	Freeze On
		y0 50 03 FF	Freeze Off
CAM_Preset Freeze	8x 09 04 62 02 FF	y0 50 02 FF	Preset Freeze On
		y0 50 03 FF	Preset Freeze Off
Firmware version	8x 09 36 69 04 FF	y0 50 0p 0q 0r 0s 0t 0u 0v 0w FF	fw_ver: p.q.rstu.vw
USB Status	8x 09 36 69 05 FF	y0 50 00 FF	USB cable plug out
		y0 50 01 FF	USB cable plug in
UVC Status	8x 09 36 69 06 FF	y0 50 00 FF	UVC stream off
		y0 50 01 FF	UVC stream on

VISCA over IP Settings

PORT

Internet protocol	IPv4
Transport protocol	UDP
Port address	52381

FORMAT

	byte 0	byte 1	byte 2	byte 3	byte 4	byte 5	byte 6	byte 7	byte8 ~~~ byte23	
func	Payload type		Payload length		Sequence number			Payload (1 to 16 bytes)		
data	Value1	Value2	1~16 (0x0001~0x0010)		0X00000000 ~ 0XFFFFFFF			VISCA Packet (see page VISCA)		

Payload type

Name	Value1	Value2	Description
VISCA command	0x01	0x00	Stores the VISCA command.
VISCA inquiry	0x01	0x10	Stores the VISCA inquiry.
VISCA reply	0x01	0x11	Stores the reply for the VISCA command or VISCA inquiry

For VISCA over IP command strings, **8x** represents a command from the controller, with x as the socket number—typically 1 (**x = 1 → 81**).

Command Set	Command	Command Packet	Comments
Pan-tilt Drive	Left	8x 01 06 01 VV WW 01 03 FF Example : 01 00 00 09 00 00 00 01 81 01 06 01 07 07 01 03 FF	VV: Pan speed setting 0x01 (low speed) to 0x18 (high speed) WW: Tilt speed setting 0x01 (low speed) to 0x18 (high speed)

Controller

Device

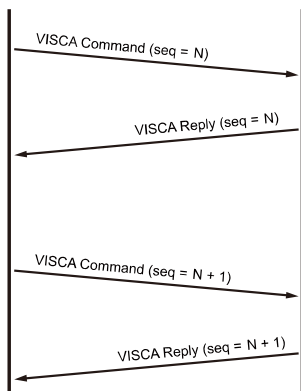

CGI Commands

CGI List for Video Transmission					
CGI item name	URL	Command	Parameter Name	Parameter value	Description
Get JPEG	/snapshot				1280x720 jpg
Get RTSP stream	rtsp://ip/live_st1				
Get MJPG	http://IP/html/live.html				

CGI List for Camera Control					
CGI item name	URL	Command	Parameter Name	Parameter value	Description
up start	/cgi-bin?SetPtzf=	1,0,1&(random)			
up end	/cgi-bin?SetPtzf=	1,0,2&(random)			
down start	/cgi-bin?SetPtzf=	1,1,1&(random)			
down end	/cgi-bin?SetPtzf=	1,1,2&(random)			
left start	/cgi-bin?SetPtzf=	0,1,1&(random)			
left end	/cgi-bin?SetPtzf=	0,1,2&(random)			
right start	/cgi-bin?SetPtzf=	0,0,1&(random)			
right end	/cgi-bin?SetPtzf=	0,0,2&(random)			
zoom_in start	/cgi-bin?SetPtzf=	2,0,1&(random)			
zoom_in end	/cgi-bin?SetPtzf=	2,0,2&(random)			
zoom_out start	/cgi-bin?SetPtzf=	2,1,1&(random)			
zoom_out end	/cgi-bin?SetPtzf=	2,1,2&(random)			
set preset:	/cgi-bin?ActPreset =	1,N&(random)			N : position
load preset:	/cgi-bin?ActPreset =	0,N&(random)			N : position
set preset speed	/cgi-bin?Set=preset_speed,3,val	val: {min: 1, max: 6}			
Absolute Position (Pan)	/cgi-bin?Set=ptz_p,3,val	val: {min: 2048, mid: 962944, max: 1925888}			Follows CGI preset speed

Absolute Position (Tilt)	/cgi-bin?Set=ptz_t,3,val	val: {min: 2048, mid: 165696, max: 662784}			Follows CGI preset speed
Absolute Position (Zoom)	/cgi-bin?Set=ptz_z,3,val	val: {min: 2048, mid: 14224, max: 28448}			Follows CGI preset speed
CGI List for Various Settings					
exposure value	/cgi-bin?Set=	img_expo_expo,3,N&(random)	value	1 ~ 9	N : value
saturation	/cgi-bin?Set=	img_saturation,3,N&(random)	value	0 ~ 10	N : value
contrast	/cgi-bin?Set=	img_contrast,3,N&(random)	value	0 ~ 4	N : value
Reboot	GET(Basic Authentication)	/cgi-bin?OnePush=!			
Factory Reset	GET(Basic Authentication)	/cgi-bin?OnePush=d			
RTMP Start streaming	/cgi-bin?Set=	vdo_rtmp_enable,3,1			
RTMP Stop streaming	/cgi-bin?Set=	vdo_rtmp_enable,3,0			
Save RTMP server URL		/cgi-bin?SaveRtmpUrl=		value empty for clearing up the field	
Save RTMP stream Key		/cgi-bin?SaveRtmpKey=		value empty for clearing up the field	
Inquiry for RTMP status		/cgi-bin?Get=vdo_rtmp_status		Streaming: vdo_rtmp_status=2 Stopped: vdo_rtmp_status=0	
Get RTMP server URL		/cgi-bin?GetRtmpUrl			
Get RTMP stream key		/cgi-bin?GetRtmpKey			
USB status	GET(Basic Authentication)	/cgi-bin?Get=usb_status_inquire,3			
	- Reply	"usb_status_inquire,3=X\r\n"	X: 0(plug out), 1(plug in)		
UVC status	GET(Basic Authentication)	/cgi-bin?Get=uvc_status_inquire,3			
	- Reply	"uvc_status_inquire,3=X\r\n"	X: 0(stream off), 1(stream on)		

Status get (Model name & mac & FW_VER)		/cgi-bin?SetString=sys_name&net_mac&sys_fw_version&_=1635216271678		http://10.100.105.110/cgi-bin?GetString=sys_name&net_mac&sys_fw_version&_=1635216271678	
Serial No. get		/cgi-bin?GetSerialNumber&_=1635216271680		http://10.100.105.110/cgi-bin?GetSerialNumber&_=1635216271680	
script (Using cURL to update firmware)	curl.exe -X POST --user NAME:PASSWORD -F file1=@./ISP_FILE "http://IP_ADDRESS/system/"			<p>Please download curl (curl for Windows), this is a command line tool for network transferring. Put curl.exe and ISP file in the same folder. and then execute the script to upgrade camera.</p> <p>For example, ISP file is 0.0.000.29.dat , IP address is 10.100.105.109 and username:password is 1:1 , you can enter this script to execute ISP process.</p> <p>curl.exe -X POST --user 1:1 -F file1=@./0.0.000.29.dat "http://10.100.105.109/system/"</p>	