

# AVER VISCA

## Specification

---

# Table of Content

- 1 Introduction..... 3
- 2 RS232..... 3
  - Baud rate: 2400, 4800, 9600 (default), 115200 bps..... 3
  - Date bits: 8 ..... 3
  - Start bit: 1..... 3
  - Stop bit: 1 ..... 3
  - Parity: None ..... 3
  - Flow control: None. .... 3
- 3 VISCA message format ..... 3
  - 3.1 COMMANDS AND RESPONSES FORMAT..... 3

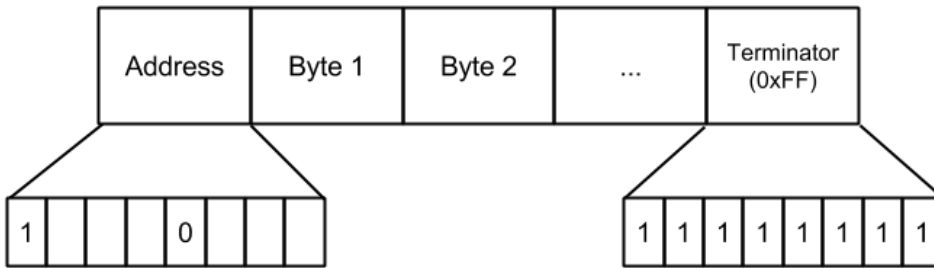

..... 4

- 3.2 COMMAND ..... 4

- 4 Revision History ..... 11
- 5 RS232 connection ..... 12

## 1 Introduction

AVER VISCA protocol provides an interface through RS232 for remote devices to communicate with the conference camera. This document contains information about the use of AVER VISCA protocol, and is intended for system integrators.

## 2 RS232

- Baud rate: 2400, 4800, 9600 (default), 115200 bps.
- Data bits: 8
- Start bit: 1
- Stop bit: 1
- Parity: None
- Flow control: None.

## 3 VISCA message format

### 3.1 Commands and responses format

The minimum length of any command or response is 3 bytes:

- Address byte (1)
  - Command:
 

The most significant 4 bits are sender address, and the least significant 4 bits are receiver address. We only support one host; the sender address must always be 0x8X. 7 receiver address supported, start from 1. (I.e. address 1: 0x81, address 2: 0x82 ...). Command address presents as 8x (see bellow command table).
  - Reply:
 

Only most significant 4 bits are used as reply address. (I.e. address 1: 0x90, address 2: 0xa0, ...). Reply address presents as y0 (see bellow command table).
- Message bytes (1..14)
 

You may get more information from bellow command table.
- Terminator byte (1)
 

All message must be terminated with 0xFF.

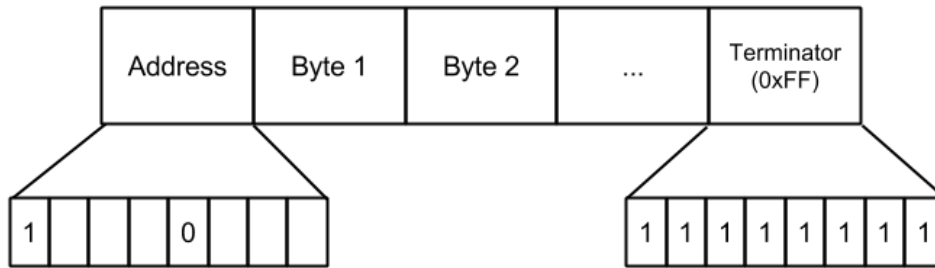

## 3.2 Command

### 3.2.1 VISCA

Command	Packet	Reply Message	Comments
Address_Set	88 30 01 FF	88 30 02 FF	Always broadcasted.
IF_Clear	8x 01 00 01 FF	y0 50 FF	x = <b>Cam address</b>
IF_Clear(broadcast)	88 01 00 01 FF	88 01 00 01 FF	The same command is returned.
Power_On	8x 01 04 00 02 FF		Enter force suspend mode
Power_Off	8x 01 04 00 03 FF		Leave force suspend mode
Power_Reset	8x 01 04 00 00 FF		Device reboot
PT_Stop	8x 01 06 01 00 00 03 03 FF	y0 50 FF	
PT_Up	8x 01 06 01 0P 0T 03 01 FF		P = <b>Pan speed</b> (0~0x0F)
PT_Down	8x 01 06 01 0P 0T 03 02 FF		T = <b>Tilt speed</b> (0~0x0F)
PT_Left	8x 01 06 01 0P 0T 01 03 FF		
PT_Right	8x 01 06 01 0P 0T 02 03 FF		
PT_UpLeft	8x 01 06 01 0P 0T 01 01 FF		
PT_UpRight	8x 01 06 01 0P 0T 02 01 FF		
PT_DownLeft	8x 01 06 01 0P 0T 01 02 FF		
PT_DownRight	8x 01 06 01 0P 0T 02 02 FF		
PT_Calibration	8x 01 06 05 FF		

PT_Direct	8x 01 06 02 00 00 0Y 0Y 0Y 0Y 0V 0V 0V 0V FF		0Y 0Y 0Y 0Y:Pan position1 0V 0V 0V 0V:Tilt position1
Zoom_Stop	8x 01 04 07 00 FF		
Zoom_Tele	8x 01 04 07 2y FF		y = not support(zoom speed)
Zoom_Wide	8x 01 04 07 3y FF		
Zoom_Direct	8x 01 04 47 0Y 0Y 0Y 0Y FF		0Y 0Y 0Y 0Y:Zoom position1
Focus_Stop	8x 01 04 08 00 FF		
Focus_Far	8x 01 04 08 20 FF		
Focus_Near	8x 01 04 08 30 FF		
Focus_Auto_Mode	8x 01 04 38 02 FF		
Focus_Manual_Mode	8x 01 04 38 03 FF		
Focus_OnePush_Trigger	8x 01 04 18 01 FF		Trigger once
WB_Auto_Mode	8x 01 04 35 00 FF		
WB_One_Push_Mode	8x 01 04 35 03 FF		
WB_Manual_Mode	8x 01 04 35 05 FF		
WB_One_Push_Trigger	8x 01 04 10 05 FF		Trigger once
WB_Rgain_Up	8x 01 04 03 02 FF		WB temperature up
WB_Rgain_Down	8x 01 04 03 03 FF		WB temperature down
WB_Bgain_Up	8x 01 04 04 02 FF		WB temperature down
WB_Bgain_Down	8x 01 04 04 03 FF		WB temperature up
AE_Auto_Mode	8x 01 04 39 00 FF		
AE_Gain_Up	8x 01 04 0C 02 FF		
AE_Gain_Down	8x 01 04 0C 03 FF		
ExpComp_Up	8x 01 04 0E 02 FF		
ExpComp_Down	8x 01 04 0E 03 FF		
Color_Gain	8x 01 04 49 00 00 00 0p FF		p = gain val
Color_Hue	8x 01 04 4F 00 00 00 0p FF		p = hue val
Backlight_On	8x 01 04 33 02 FF		if not supported Backlight, change to control WDR
Backlight_Off	8x 01 04 33 03 FF		
WDR_On	8x 01 04 33 02 FF		if not supported WDR, change to control Backlight
WDR_Off	8x 01 04 33 03 FF		

CAM_set	8x 01 04 3F 01 YY FF		YY = preset num(0~0x7F)
CAM_recall	8x 01 04 3F 02 YY FF		
CAM_Profile_Read	8x 01 04 40 01 YY FF		YY = profile num(0x00~0x05)
CAM_Profile_Save	8x 01 04 40 02 YY FF		only for CAM520
CAM_PIP_Set_USB	8x 01 04 7F 00 YY FF		"YY = pip num(0x00~0x04, 0x12~0x14) 00 = PTZ lens 01 = AI lens 02 = PTZ + right down AI 03 = PTZ + left up AI 04 = left PTZ + right AI 12 = AI + right down PTZ 13 = AI + left up PTZ 14 = left AI + right PTZ <b>*Support : CAM550"</b>
CAM_PIP_Set_HDMI	8x 01 04 7F 01 YY FF		YY = pip num(0x00~0x04, 0x12~0x14) 00 = PTZ lens 01 = AI lens 02 = PTZ + right down AI 03 = PTZ + left up AI 04 = left PTZ + right AI 12 = AI + right down PTZ 13 = AI + left up PTZ 14 = left AI + right PTZ <b>*Support : CAM550</b>
CAM_Track_Trigger	8x 01 04 7D 00 00 FF		Framing Trigger Once <b>*Support : VB342+, VB342Pro, VB350, CAM540, CAM550, CAM520Pro/Pro2, VC520Pro/Pro2</b>
CAM_Track_Disable	8x 01 04 7D 01 00 FF		AI Off <b>*Support : VB342+, VB342Pro, VB350, CAM540, CAM550, CAM520Pro/Pro2, VC520Pro/Pro2</b>

CAM_Track_Auto	8x 01 04 7D 02 00 FF		Auto Framing Mode *Support : VB342+, VB342Pro, VB350, CAM540, CAM550, CAM520Pro/Pro2, VC520Pro/Pro2
CAM_Track_Manual	8x 01 04 7D 03 00 FF		Manual Framing Mode *Support : VB342+, VB342Pro, VB350, CAM540, CAM550, CAM520Pro/Pro2, VC520Pro/Pro2
CAM_Track_Audio_Tracking	8x 01 04 7D 04 00 FF		Audio Tracking *Support : VB342+, VB342Pro, VB350
CAM_Track_Audio_Frame	8x 01 04 7D 05 00 FF		Audio Frame *Support : VB342+, VB350
CAM_Track_Audio_Preset	8x 01 04 7D 06 00 FF		Audio Preset tracking *Support : VB342+
CAM_Track_Presentation	8x 01 04 7D 07 00 FF		Pesentation Mode *Support : VB342Pro, VB350
CAM_Track_Set_Start_Position	8x 01 04 7D 10 YY FF		Choose a preset point so that camera can detect participants from the wide view of the assigned preset area direction.  YY= preset point 0x00~0x09 : preset 0~9 0x0A : Center of the screen image  *Support : VB342+, VB342Pro, CAM540, CAM520Pro/Pro2, VC520Pro/Pro2

CAM_Track_Source	8x 01 04 7D 11 YY FF		YY= AI detection source 01 : 2nd AI lens 02 : PTZ lens  *Support : CAM550
CAM_Track_Gusture_On	8x 01 04 7D 20 02 FF		*Support : CAM550, VB342Pro, VB350
CAM_Track_Gusture_Off	8x 01 04 7D 20 03 FF		*Support : CAM550, VB342Pro, VB350

**Audio Command**

ADO_Mute_Tigger	8x 01 08 00 00 FF		*Support : VB342+, VB342Pro, VB350
ADO_Mute_On	8x 01 08 00 01 FF		*Support : VB342+, VB342Pro, VB350
ADO_Mute_Off	8x 01 08 00 02 FF		*Support : VB342+, VB342Pro, VB350
ADO_Volume_Up	8x 01 08 01 01 FF		*Support : VB342+, VB342Pro, VB350
ADO_Volume_Down	8x 01 08 01 02 FF		*Support : VB342+, VB342Pro, VB350

**Inquiry Command**

Version_Inq	8x 09 00 02 FF	y0 50 GG GG HH HH JJ JJ KK FF	GGGG = Vender ID HHHH = Model ID JJJJ = Version KK = Maximum socket #
PT_Pos_Inq	8x 09 06 12 FF	y0 50 0Y 0Y 0Y 0Y 0V 0V 0V 0V FF	0Y 0Y 0Y 0Y: Pan position 0V 0V 0V 0V: Tilt position
Zoom_Pos_Inq	8x 09 04 47 FF	y0 50 0Y 0Y 0Y 0Y FF	0Y 0Y 0Y 0Y: Zoom position

Track_Status_Inq	8x 09 04 7D FF	y0 50 00 00 YY 00 FF	YY = tracking mode 01 : AI off 02 : Auto Framing 03 : Manual Framing 04 : Audio Tracking 05 : Audio Frame 06 : Audio Preset 07 : Presentation  *Support : VB342+, VB342Pro, VB350, CAM540, CAM550, CAM520Pro/Pro2, VC520Pro/Pro2
------------------	----------------	----------------------	---

### 3.2.2 PELCO P

PAN AND TILT COMMANDS P/T bit(byte4.0) = 0

	byte 1	byte 2	byte 3	byte 4	byte 5	byte 6	byte 7	byte 8
func	STX	ADDR	data1	data2	data3	data4	ETX	checksum
data	0xA0	0~7F	cmd 1	cmd 2	Pan speed	Tilt speed	0xAF	1~7 XOR

note : speed = 0x00~0x30

byte3 : command 1

bit 7	bit 6	bit 5	bit 4	bit 3	bit 2	bit 1	bit 0
NA	CAM ON	NA	CAM ON/OFF	NA	NA	NA	NA

note : power off : byte3.6 = 0 & byte3.4 = 1

byte4 : command 2

bit 7	bit 6	bit 5	bit 4	bit 3	bit 2	bit 1	bit 0
NA	ZOOM Wide	ZOOM Tele	TILT Down	TILT Up	PAN Left	PAN Right	P/T bit 0(always)

EXTENDED COMMAND SET P/T bit(byte4.0) = 1

	byte 1	byte 2	byte 3	byte 4	byte 5	byte 6	byte 7	byte 8
func	STX	ADDR	data1	data2	data3	data4	ETX	checksum
Set Preset XX	0xA0	0~7	0x00	0x03	0x00	Preset #	0xAF	1~7 XOR
Go To Preset XX	0xA0	0~7	0x00	0x07	0x00	Preset #	0xAF	1~7 XOR
Track ON	0xA0	0~7	0x00	0x65	0x00	0x00	0xAF	1~7 XOR
Track OFF	0xA0	0~7	0x00	0x67	0x00	0x00	0xAF	1~7 XOR
WOL ON	0xA0	0~7	0x00	0x69	0x00	0x00	0xAF	1~7 XOR
WOL OFF	0xA0	0~7	0x00	0x6B	0x00	0x00	0xAF	1~7 XOR
Read Profile XX	0xA0	0~7	0x00	0x6D	0x00	Profile #	0xAF	1~7 XOR
Save To Profile XX	0xA0	0~7	0x00	0x6F	0x00	Profile #	0xAF	1~7 XOR
Track Trigger	0xA0	0~7	0x00	0x63	0x00	0x00	0xAF	1~7 XOR

note : Preset # : 0x01 ~ 0x7F  
 Profile # : 0x01 ~ 0x05

### 3.2.3 PELCO D

PAN AND TILT COMMANDS P/T bit(byte4.0) = 0

	byte 1	byte 2	byte 3	byte 4	byte 5	byte 6	byte 7
func	SYNC	ADDR	cmd 1	cmd 2	data1	data2	checksum
data	0xFF	1~80	cmd 1	cmd 2	Pan speed	Tilt speed	2~6 SUM

note : speed = 0x00~0x30

byte3 : command 1

bit 7	bit 6	bit 5	bit 4	bit 3	bit 2	bit 1	bit 0
SENS E ON	NA	NA	NA	CAM ON/OFF	NA	NA	NA

note : power off : byte3.7 = 0 & byte3.3 = 1

byte4: command 2

bit 7	bit 6	bit 5	bit 4	bit 3	bit 2	bit 1	bit 0
NA	ZOOM Wide	ZOOM Tele	TILT Down	TILT Up	PAN Left	PAN Right	P/T bit 0(always)

EXTENDED COMMAND SET P/T bit(byte4.0) =

		1						
		byte 1	byte 2	byte 3	byte 4	byte 5	byte 6	byte 7
func		SYNC	ADDR	data1	data2	data3	data4	checksum
Set Preset XX		0xFF	1~8	0x00	0x03	0x00	Preset #	2~6 SUM
Go To Preset XX		0xFF	1~8	0x00	0x07	0x00	Preset #	2~6 SUM
Track ON		0xFF	1~8	0x00	0x65	0x00	0x00	2~6 SUM
Track OFF		0xFF	1~8	0x00	0x67	0x00	0x00	2~6 SUM
WOL ON		0xFF	1~8	0x00	0x69	0x00	0x00	2~6 SUM
WOL OFF		0xFF	1~8	0x00	0x6B	0x00	0x00	2~6 SUM
Read Profile XX		0xFF	1~8	0x00	0x6D	0x00	Profile #	2~6 SUM
Save To Profile XX		0xFF	1~8	0x00	0x6F	0x00	Profile #	2~6 SUM
Track Trigger		0xFF	1~8	0x00	0x63	0x00	0x00	2~6 SUM

note : Preset # : 0x01 ~ 0x7F  
Profile # : 0x01 ~ 0x05

1. Position is separate into 0Y 0Y 0Y 0Y, user may assemble back as YYYY. (I.e. 0x1234 → 01 02 03 04)
2. We also support AVer CL01 control panel but not all the functions. What follows is the items we don't support on CL01.



: We don't support MENU function.



: We don't support Reset function.



: We don't support In Door, Out Door and ATW. As for R Gain and B Gain, they work as color temperature adjustment instead.



: We don't support Shutter Priority, Iris Priority and Bright.

## 4 Revision History

Date	Rev.	Author	Content
2015.07.31	1.0	Drama	Draft

2016.02.23	1.1	Drama	Modified. Zoom_Tele & Zoom_Wide.
2018.09.25	1.2	William	Add. CAM_Power_ON & CAM_Power_OFF
2019.10.08	1.3	William	Add. CAM_Track Command
2019.12.24	1.4	Drama	Add. CAM520Pro/VC520 Pro
2020.06.23	1.5	William	Add. ADO_Mute & ADO_Volume
2020.7.10	1.6	Sarah	Add CAM520Pro/VC520 Pro RS232 connection
2020.8.18	1.7	Sarah	Correction on CAM520Pro/VC520 Pro RS232 connection
2021.4.14	2.0	William	Add more commands, including supporting external control panel, such as AVer CL01.
2022.3.28	2.2	Vanessa	Add VB342 Pro and CAM550
2022.4.1	2.3	Vanessa	Add VB342Pro, VB350, CAM550 command list
2022.6.2	2.4	Vanessa	Add USB PIP command
2022.6.7	2.5	Vanessa	Modified CAM_PIP_Set_USB and CAM_PIP_Set_HDMI
2022.8.29	2.6	Jeff	Add comments for VISCA Power_on & Power_off command

## 5 RS232 connection

Model: CAM520,VC520+, CAM540, VB342+, VB342 Pro, VB350

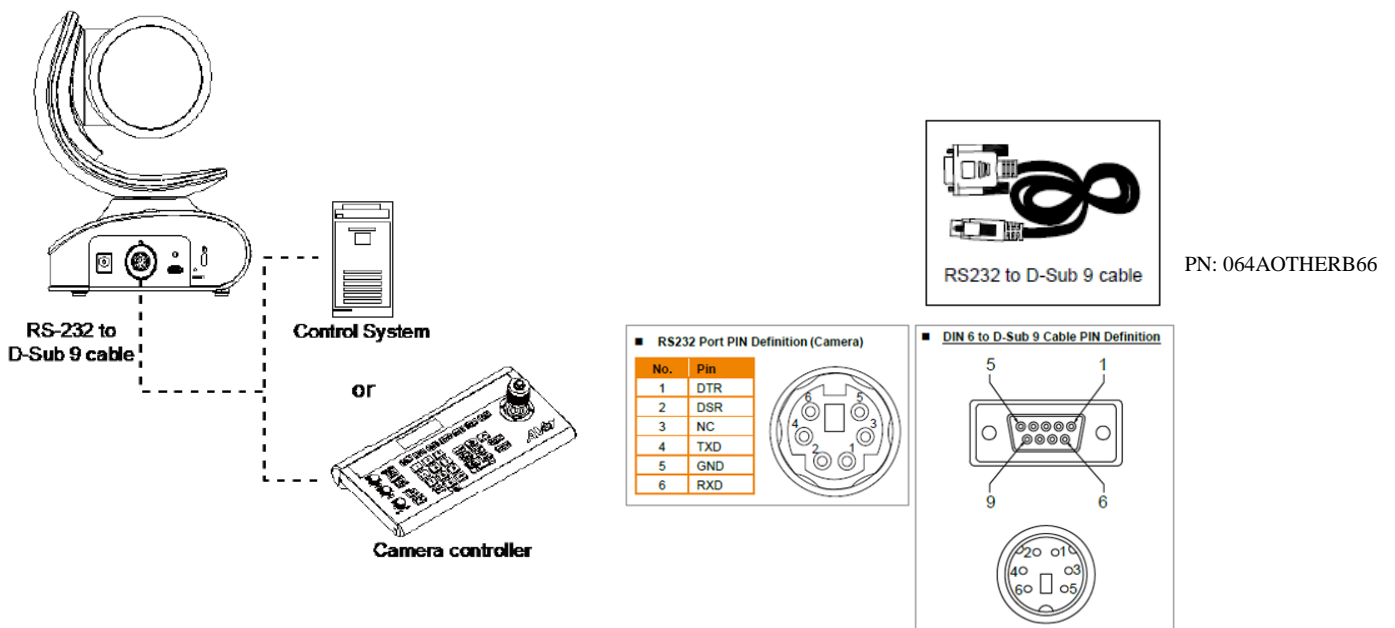

Model: CAM520 Pro/Pro2, VC520 Pro/Pro2, CAM550

**Camera RS232 Port Pin Definition**

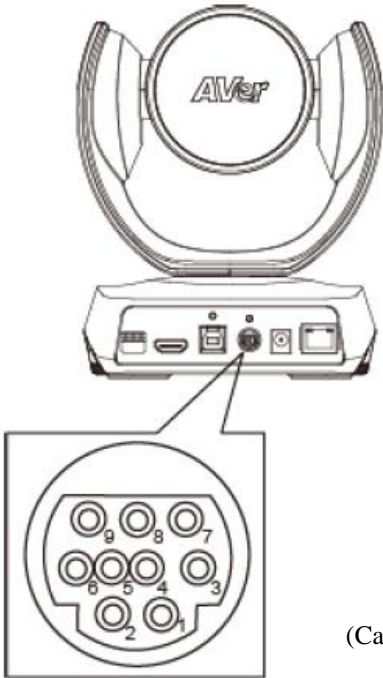

(Camera)

Function	Mini DIN9 PIN #	I/O Type	Signal	Description
VISCA IN	1	Output	DTR	Data Terminal Ready
	2	Input	DSR	Data Set Ready
	3	Output	TXD	Transmit Data
	6	Input	RXD	Receiver Data
VISCA OUT	7	Output	DTR	Data Terminal Ready
	4	Input	DSR	Data Set Ready
	8	Output	TXD	Transmit Data
	9	Input	RXD	Receiver Data
	5	---	---	Not connect

■ **Computer/Keyboard Controller and Camera Connection**

Direct Connection

If users don't buy AVer RS232 adaptor cable, please refer to the pin connection shown below.

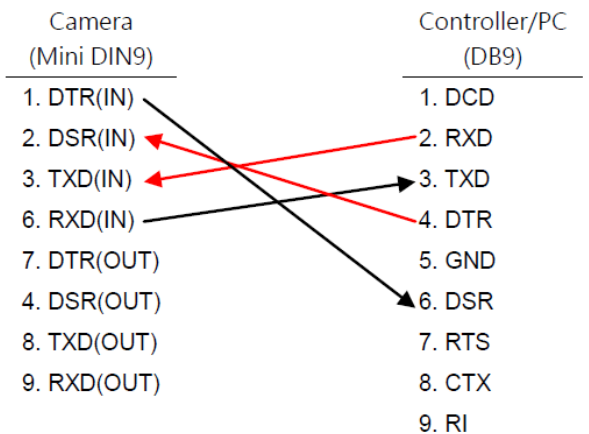
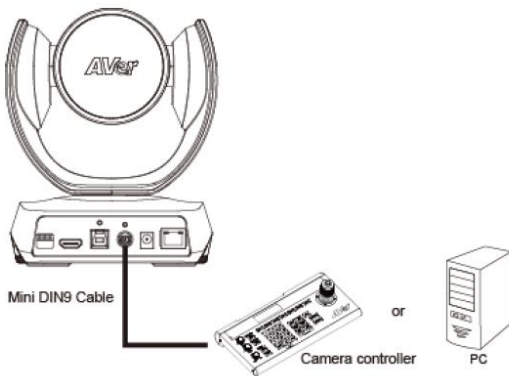

**Use the RS232 mini DIN9 to mini DIN8 cable** (included with CAM520 Pro(PoE) SKU, otherwise sold separately).

Users can purchase AVer RS232 min DIN9 to mini DIN8 adaptor cable\* to connect with Computer or keyboard/controller.

1. RS232 (mini DIN9 to mini DIN8) adaptor cable (PN: 064AOTHERCDC)

2. Users can also purchase a miniDIN8 to D-Sub9 cable to connect with camera controller. (PN: 064AOTHERBPK)

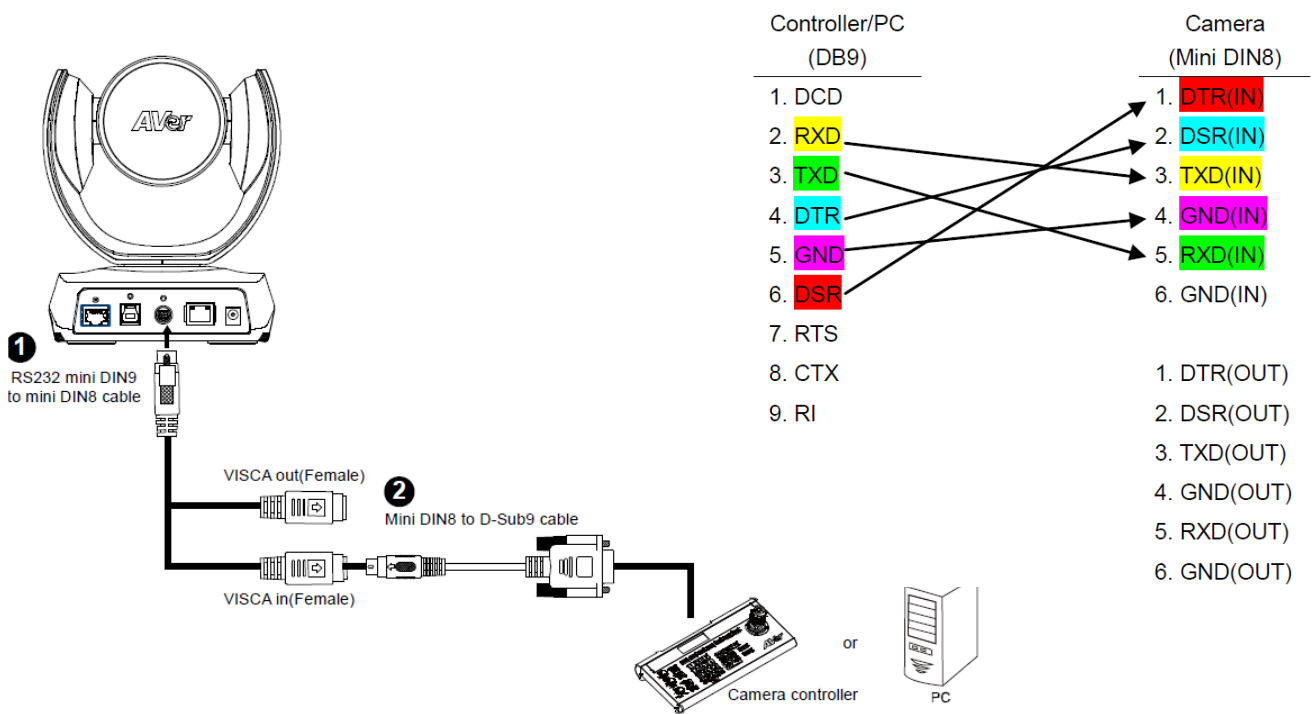

■ RS232 mini DIN9 to mini DIN8 Cable Pin Definition

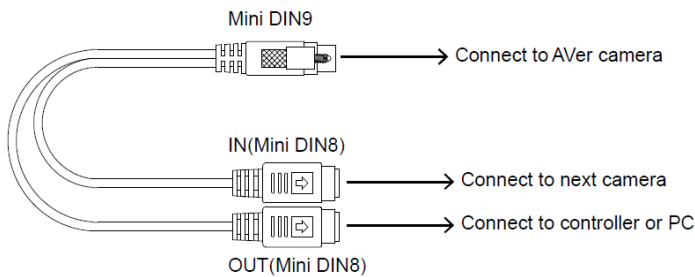

Mini DIN8 Pin Definition

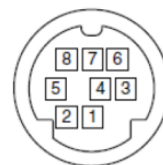

No.	Pin
1	DTR
2	DSR
3	TXD
4	GND
5	RXD
6	GND
7	NC
8	NC

■ Camera Cascade Connection

**Direct Connection**

If users don't buy AVer RS232 adaptor cable, please refer to the pin connection shown below for cascading cameras.

Total can connect up to 7 cameras.

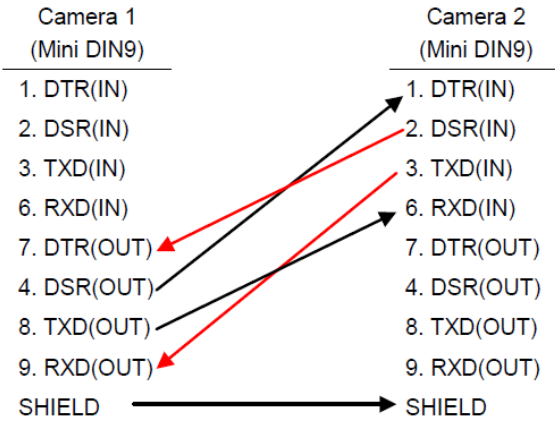
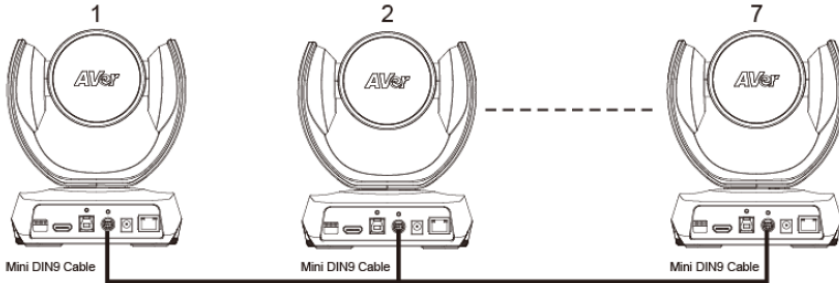

**Use the RS232 mini DIN9 to mini DIN8 cable**

Total can connect up to 7 cameras.

To facilitate the camera cascade, users can purchase AVer RS232 adaptor cable.

Connect camera with AVer mini DIN9 to mini DIN8 adaptor cable. Connect the mini DIN8 female side to male mini DIN8 Visca cable (Users have to buy it in the market) and then connect AVer mini DIN9 to mini DIN8 adaptor cable again to connect to next camera.

