

CAM570

Conference Camera

— **User Manual** —

Warning

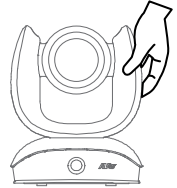

- Hold the bottom of the camera with both hands to carry the camera. Whether the camera is connected to power or not, do not grab any part of the lens or the lens holder to carry the camera or adjust pan and tilt.
- Do not drop the camera or subject it to physical shock.
- Ensure the power supply voltage is correct before using the camera.
- Do not place the camera where the cord can be stepped on as this may result in fraying or damage to the lead or the plug.
- To reduce the risk of fire or electric shock, do not expose the camera to rain or moisture. Warranty will be voided if any unauthorized modifications are done to the camera.

Federal Communications Commission Statement

NOTE: This equipment has been tested and found to comply with the limits for a Class A digital device, pursuant to part 15 of the FCC Rules. These limits are designed to provide reasonable protection against harmful interference when the equipment is operated in a commercial environment. This equipment generates, uses, and can radiate radiofrequency energy and, if not installed and used in accordance with the instruction manual, may cause harmful interference to radio communications. Operation of this equipment in a residential area is likely to cause harmful interference in which case the user will be required to correct the interference at his own expense.

FCC Caution: Any changes or modifications not expressly approved by the party responsible for compliance could void the user's authority to operate this equipment.

This device complies with part 15 of the FCC Rules.

Operation is subject to the following two conditions:

- (1) This device may not cause harmful interference, and
- (2) this device must accept any interference received, including interference that may cause undesired operation.

This Class A digital apparatus complies with Canadian ICES-003. Cet appareil numérique de la classe A est conforme à la norme NMB-003 du Canada.

PSTI Statement of Compliance

Please refer to the following website: <https://www.aver.com/product-security-advisory>

Warning

This is a class A product. In a domestic environment this product may cause radio interference in which case the user may be required to take adequate measures.

Caution

Risk of explosion if battery is replaced by an incorrect type. Dispose of used batteries according to the instructions.

VCCI-A

この装置は、クラス A 機器です。この装置を住宅環境で使用すると電波妨害を引き起こすことがあります。この場合には使用者が適切な対策を講ずるよう要求されることがあります。

(注)本製品同梱の電源ケーブルは、本製品同梱の電源アダプタでのみ使用してください。
本製品同梱の電源ケーブルは、他の電気機器では使用できません。

사용자안내문
이 기기는 업무용 환경에서 사용할 목적으로 적합성평가를 받은 기기로서 가정용 환경에서 사용하는 경우 전자파간섭의 우려가 있습니다.
※ 사용자 안내문은 "업무용 방송통신기자재"에만 적용됩니다.

기종별	사용자안내문
A 급 기기 (업무용 방송통신기자재)	이 기기는 업무용(A 급) 전자파적합기기로서 판매자 또는 사용자는 이 점을 주의하시기 바라며, 가정외의 지역에서 사용하는 것을 목적으로 합니다.

遥控器電池安全信息

- 请将电池存放在凉爽与干燥的位置。
- 不要将电量用尽的电池弃置在家庭废弃物中。请将电池弃置在特定回收处，或送回原购买的商店。
- 如果长时间不使用电池，请将其取出。电池漏液与腐蚀可能会损坏遥控器，请以安全方式弃置电池。
- 不可混用新旧电池。
- 不可混用不同类型的电池：碱性、标准（碳锌）或可充电（镍镉）电池。
- 不可将电池弃置于火源中。
- 请勿尝试让电池端子短路。

DISCLAIMER

No warranty or representation, either expressed or implied, is made with respect to the contents of this documentation, its quality, performance, merchantability, or fitness for a particular purpose.

Information presented in this documentation has been carefully checked for reliability; however, no responsibility is assumed for inaccuracies. The information contained in this documentation is subject to change without notice.

In no event will AVer Information Inc. be liable for direct, indirect, special, incidental, or consequential damages arising out of the use or inability to use this product or documentation, even if advised of the possibility of such damages.

TRADEMARKS

“AVer” is a trademark owned by AVer Information Inc. Other trademarks used herein for description purpose only belong to each of their companies.

COPYRIGHT

©2025 AVer Information Inc. All rights reserved. | December 26, 2025

All rights of this object belong to AVer Information Inc. Reproduced or transmitted in any form or by any means without the prior written permission of AVer Information Inc. is prohibited. All information or specifications are subject to change without prior notice.

More Help

For FAQs, technical support, software and user manual download, please visit:

Non-USA

Download Center: <https://www.aver.com/download-center>

Technical Support: <https://www.aver.com/technical-support>

USA

Download Center: <https://www.averusa.com/business/support>

Technical Support: <https://averusa.force.com/support/s/contactsupport>

Contact Information

Headquarters

AVer Information Inc.
8F, No.157, Da-An Rd.
Tucheng Dist., New Taipei
City 236042, Taiwan
Tel: +886 (2) 2269 8535

USA Branch Office

AVer Information Inc., Americas
44061 Nobel Drive, Fremont,
CA 94538, USA
Tel: +1 (408) 263 3828
Toll-free: +1 (877) 528 7824

Europe Branch Office

AVer Information Europe B.V.
Westblaak 134, 3012KM,
Rotterdam, The Netherlands
Tel: +31 (0) 10 7600 550

Japan Branch Office

アバー・インフォメーション株式
会社
〒160-0023 日本東京都新宿区
西新宿 3-2-26 立花新宿ビル
7 階
Tel: +81 (0) 3 5989 0290
お客様サポートセンター(固定電
話のみ): +81 (0) 120 008 382

Vietnam Branch Office

Công ty TNHH AVer Information
(Việt Nam)
Tầng 5, 596 Nguyễn Đình
Chiểu, P.3, Quận 3,
Thành phố Hồ Chí Minh
700000, Việt Nam
Tel: +84 (0) 28 22 539 211
Hỗ trợ kỹ thuật: +84 (0) 90 70
080 77

Korea Office

한국 에버 인포메이션 (주)
서울시 종로구 새문안로 92
(신문로 1가,
광화문오피시아빌딩) 1831,
1832 호
Tel: +82 (0) 2 722 8535

Contents

Warning	2
Overview	1
Package Contents	1
Optional Accessories	1
Parts Info	2
LED Indicator	3
Pan and Tilt Angle.....	3
Remote Control.....	4
Shortcuts	5
Connection	6
Device Connection	6
Power Connection	7
HDMI Connection	8
RS-232 Connection	10
RS-232 Port Pin Definition	10
Computer/Keyboard Controller and Camera Connection	11
Camera Cascade Connection	14
Installation	16
Wall Mount Installation.....	16
Ceiling Mount Installation (Optional).....	19
Secure the Cables	22
Get Started	23
Make a Video Call.....	23
Access the Web Interface	23
AVer Device Utility	23

Room Management.....	24
Log In for the First Time	25
Web Interface.....	26
PTZ Control	26
Save, Load and Clear a Preset	27
Add and Delete Available Presets (Presets 10-127).....	27
Setting.....	28
Overview of the Floating Live View	32
Tracking Mode	33
Gesture Control	36
Video Format	37
Network.....	38
System.....	39
Room Management.....	41
Configure Settings on Room Management	41
Audio Settings.....	42
EZLive	43

Overview

Package Contents



CAM570

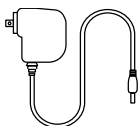

Power Adapter & Power Plug



Remote Control



AAA Battery (x2)
(US only)



USB 3.1 Type-B to Type-A Cable (3m)

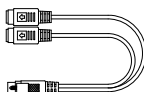

Mini Din 9 to Mini Din 8
RS-232 Adapter Cable



HDMI Cable (3m)

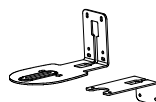

Wall Mount Bracket (x2)



M4 x 8mm
Wall Mount Screw (x2)



1/4"-20 L=7.5mm
Tripod Screw (x2)

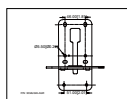

Drill Template

Optional Accessories



USB 2.0 Type-B to Type-A
Cable (5m)



Mini Din 8 to D-Sub 9
Cable

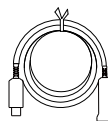

USB 3.1 Extender
10m/20m/30m

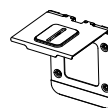

Foldable TV Mount



Ceiling Mount

*Optional Accessories may vary based on the country or region where sold.

Parts Info

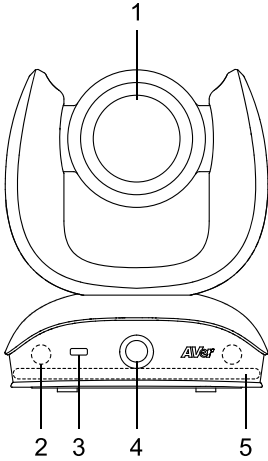

1. Main Lens
Optical zoom
2. IR Sensors
3. Status LED
4. AI Lens
95° field of view
5. Microphone Array
For audio tracking only, can't be used as a video conference audio source

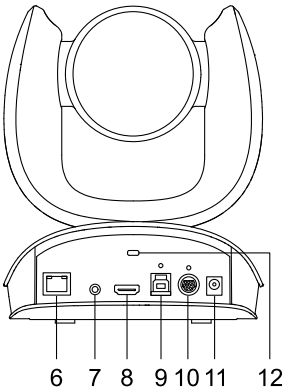

6. PoE 802.3at Port
7. Audio Input Port
8. HDMI Port
9. USB 3.1 Type-B Port
10. RS-232 In/Out Port
11. DC Power Jack
12. Kensington Lock

LED Indicator

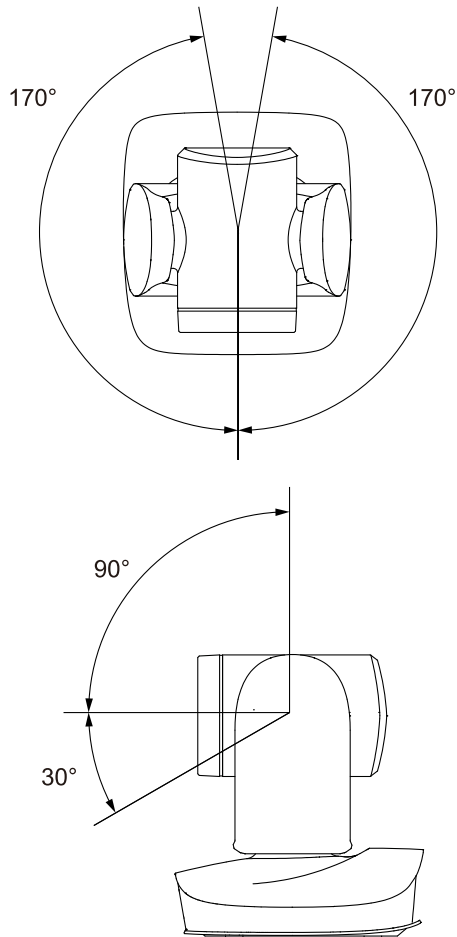

Color	Status
Solid red	Start-up
Solid orange	Standby
Solid blue	Streaming video
Flashing blue for 2 seconds	Gesture control is turned on
Flashing blue for 4 seconds	Performing a gesture command

Pan and Tilt Angle



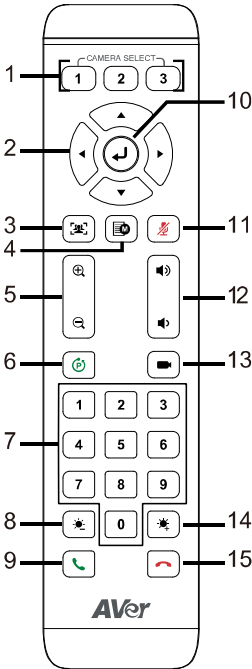











Remote Control



Name	Function
1. Camera Select	No selection is required by default to operate the camera. <ul style="list-style-type: none"> To assign a number to a camera, go to Setting > Camera Binding via the web interface or Room Management.
2. Pan-Tilt Control	Pan and tilt direction control.
3. SmartFrame	Press to frame entire group on screen. Press and hold to cycle through tracking modes. <ul style="list-style-type: none"> To hide the SmartFrame icon, go to Setting > On-Screen Menu > Off via the web interface or Room Management.
4. OSD Menu	<ul style="list-style-type: none"> Open or close the OSD menu during HDMI output. Press and hold to switch between the main lens and the AI lens during HDMI output.
5. Zoom In/Out	Zoom in or out.
6. Preset	<ul style="list-style-type: none"> To save a preset: Press and hold Preset  until save message appears on screen, then press a Number (0-9). To load a preset: Press and hold Preset , then press a Number (0-9).
7. Number Pad	
8. Brightness -	Decrease the image brightness.
9. Call/Answer	N/A
10. Enter	<ul style="list-style-type: none"> Confirm a selection. Display current AI function on closed caption.
11. Mute	N/A
12. Volume	N/A
13. Load Preset	With each press, cycle through defined presets.
14. Brightness +	Increase the image brightness.
15. Hang Up	N/A

Shortcuts

Press and Hold	To
 for 2 sec	Turn wide dynamic range (WDR) on or off.
 for 2 sec	Enable Audio Tracking.
 for 2 sec	Enable Presentation Mode.
 for 2 sec	Turn SmartFrame on or off.
 for 2 sec	Change the picture-in-picutre (PiP) position when streaming over USB or IP.
 for 2 sec	Turn RTMP streaming on or off when RTSP and RTMP are turned on.
 for 2 sec	Enter sleep mode.
 for 6 sec	Reboot.
 for 2 sec, then press 	Turn Preset Link Set 1 on or off.
 for 2 sec, then press 	Turn Preset Link Set 2 on or off.

Connection

Device Connection

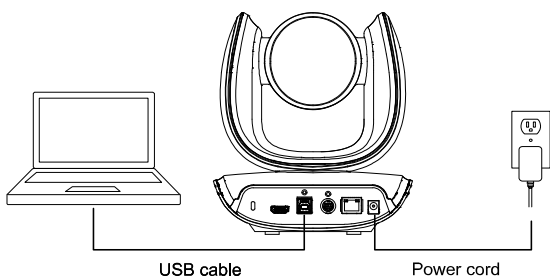

- Use the included USB cable.
- The USB 3.1 port is compatible with USB 2.0.

Maximum resolution/fps for USB 2.0 and USB 3.1 ports:

USB 2.0		USB 3.1		HDMI
YUV	M-JPEG	YUV	M-JPEG	
- 640x480 or less, up to 30fps - 720p, up to 10fps	- 1080p/60fps	- Up to 1080p/30fps - 720p/60fps	- Up to 4k/30fps - 1080p/60fps	- 1080p/60fps - 1080p/30fps

Power Connection

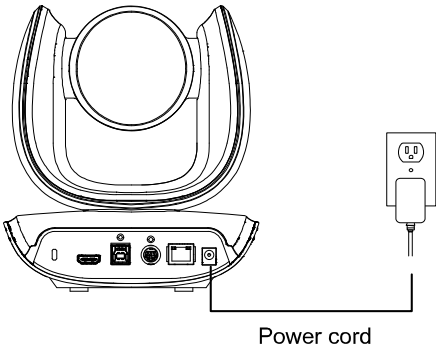

Connect the included power adapter and power cord to a wall outlet.

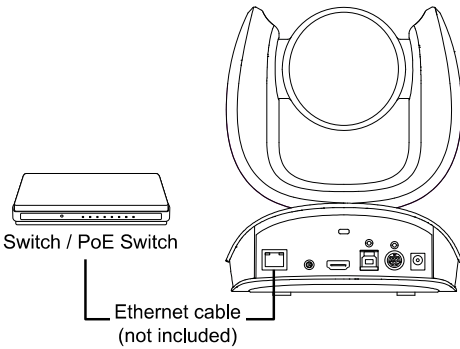

Or connect a CAT 5e FTP cable (not included) to the PoE Switch or Ethernet.

- PoE port is compatible with IEEE 802.3at.
- When streaming over IP, use a CAT 5e FTP cable (not included) for a smooth video.

HDMI Connection

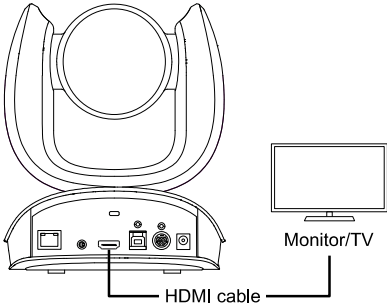

Connect with TV or monitor through the HDMI port to display camera video on the screen. Hold  button for 1 second on the Remote Control to call out the screen layout option. Select the camera image layout firstly. The default is PIP1, showing optical zoom lens image as main screen and AI lens image as small view. Under this layout, you can switch two cameras by pressing Up/Down on remote control.

[Note]

The HDMI out function will be automatically disabled when 4K resolution is selected for USB or RTSP streaming. Under this circumstance, please change RTSP and USB streaming from 4K to lower resolution if you want to enable HDMI out.

If your camera is under RTSP 4K resolution, you can press and hold the OSD Menu button on the Remote Control for 1~2 sec. to quickly change the resolution to 1080p and then you can start using the HDMI function.

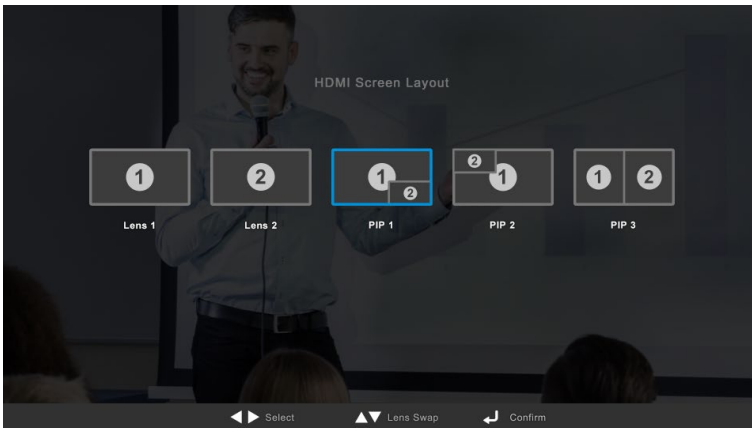

PIP View

Lens 1 The PTZ camera focuses on speaker

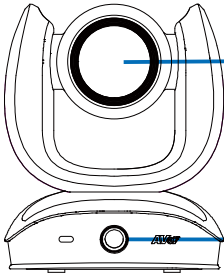

Lens 2 Shows all participants

After choosing the image layout, short press the OSD Menu button on the Remote Control and then the setting page will show up. Press right direction button to enter and configure the parameters of the camera. Short press the OSD button twice or hold it for 1 sec. to leave. The HDMI OSD setting function is the same as Web configuration interface. Please refer to [Web Settings](#) for more details.

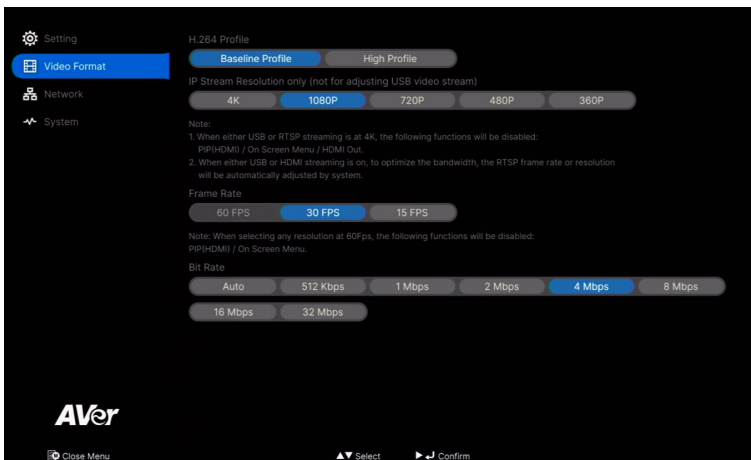

RS-232 Connection

RS-232 Port Pin Definition

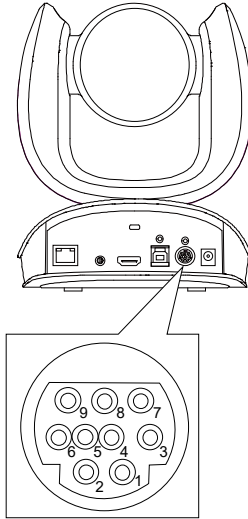

Function	Mini DIN9 PIN #	I/O Type	Signal	Description
VISCA IN	1	Output	DTR	Data Terminal Ready
	2	Input	DSR	Data Set Ready
	3	Output	TXD	Transmit Data
	6	Input	RXD	Receiver Data
VISCA OUT	7	Output	DTR	Data Terminal Ready
	4	Input	DSR	Data Set Ready
	8	Output	TXD	Transmit Data
	9	Input	RXD	Receiver Data
	5	---	---	---

Computer/Keyboard Controller and Camera Connection

Direct Connection

If users do not use AVer RS-232 adapter cable, please refer to the pin connection shown below.

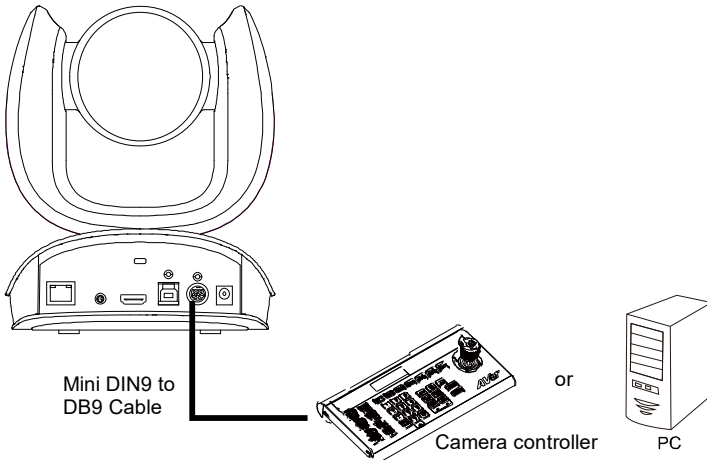

Mini DIN9

Camera

- 1. DTR (IN)
- 2. DSR (IN)
- 3. TXD (IN)
- 6. RXD (IN)
- 7. DTR (OUT)
- 4. DSR (OUT)
- 8. TXD (OUT)
- 9. RXD (OUT)

DB9

Camera controller, PC

- 6. DSR
- 4. DTR
- 2. RXD
- 3. TXD
- 1. DCD
- 5. GND
- 7. RTS
- 8. CTX
- 9. RI

Use the supplied RS-232 mini DIN9 to mini DIN8 cable

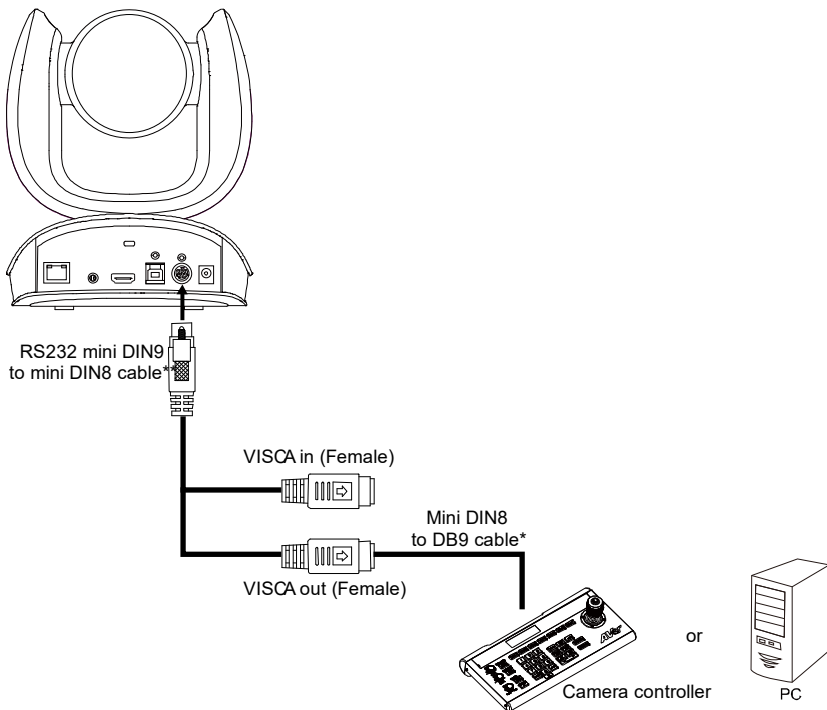

DB9

Camera controller, PC

- 1. DCD
- 2. RXD
- 3. TXD
- 4. DTR
- 5. GND
- 6. DSR
- 7. RTS
- 8. CTX
- 9. RI

Mini DIN8

Camera

- 6. GND (IN)
- 3. TXD (IN)
- 5. RXD (IN)
- 2. DSR (IN)
- 4. GND (IN)
- 1. DTR (IN)
- 1. DTR (OUT)
- 2. DSR (OUT)
- 3. TXD (OUT)
- 4. GND (OUT)
- 5. RXD (OUT)
- 6. GND (OUT)

* Mini DIN8 to D-Sub9 (DB9) cable 064AOTHERBPK is an optional item.

**** RS-232 mini DIN9 to mini DIN8 Cable Pin Definition**

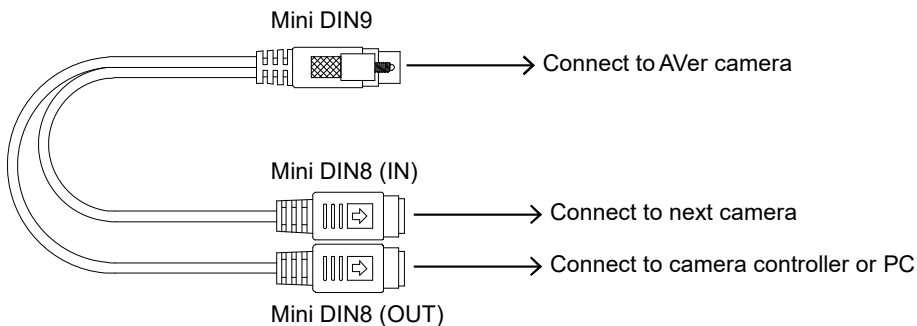

Mini DIN8 Pin Definition

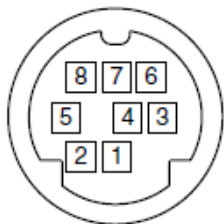

No.	Pin
1	DTR
2	DSR
3	TXD
4	GND
5	RXD
6	GND
7	NC
8	NC

Camera Cascade Connection

Direct Connection

If users do not use AVer RS-232 adapter cable, please refer to the pin connection shown below for cascading cameras.

Total can connect up to 7 cameras.

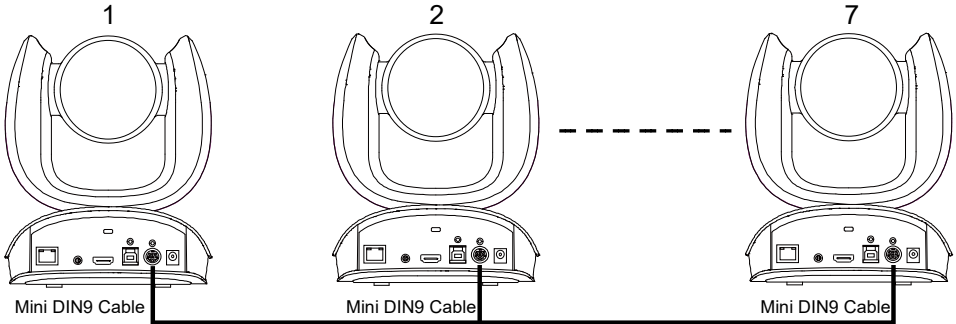

Mini DIN9

Camera 1

- 1. DTR (IN)
- 2. DSR (IN)
- 3. TXD (IN)
- 6. RXD (IN)
- 7. DTR (OUT) →
- 4. DSR (OUT) →
- 8. TXD (OUT) →
- 9. RXD (OUT) →
- SHIELD →

Mini DIN9

Camera 2

- 7. DTR (OUT)
- 4. DSR (OUT)
- 8. TXD (OUT)
- 9. RXD (OUT)
- 2. DSR (IN)
- 1. DTR (IN)
- 6. RXD (IN)
- 3. TXD (IN)
- SHIELD

Use the RS-232 mini DIN9 to mini DIN8 cable

Total can connect up to 7 cameras.

To facilitate the camera cascade, users can use AVer RS-232 adapter cable.

Connect camera with AVer mini DIN9 to mini DIN8 adapter cable. Connect the mini DIN8 female side to male mini DIN8 Visca cable (Users have to buy it in the market) and then connect AVer mini DIN9 to mini DIN8 adapter cable again to connect to next camera.

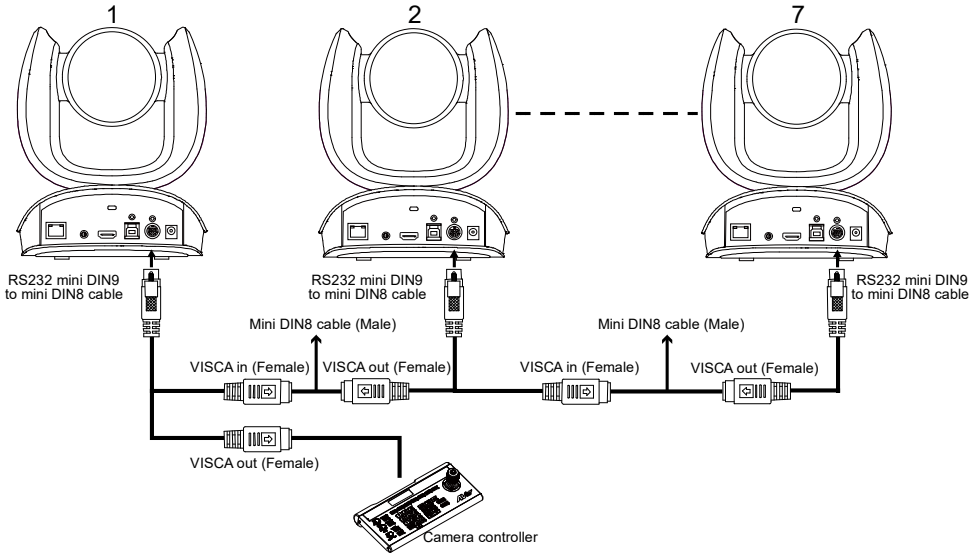

Mini DIN8

Camera 1

- 1. DTR (IN)
- 2. DSR (IN)
- 3. TXD (IN)
- 4. GND (IN)
- 5. RXD (IN)
- 6. GND (IN)

Mini DIN8

Camera 2

- 1. DTR (OUT)
- 2. DSR (OUT)
- 3. TXD (OUT)
- 4. GND (OUT)
- 5. RXD (OUT)
- 6. GND (OUT)

- 1. DTR (OUT) → 2. DSR (IN)
- 2. DSR (OUT) → 1. DTR (IN)
- 3. TXD (OUT) → 5. RXD (IN)
- 4. GND (OUT) → 4. GND (IN)
- 5. RXD (OUT) → 3. TXD (IN)
- 6. GND (OUT) → 6. GND (IN)

Installation

- The AI lens has a 95-degree field of view but lacks ePTZ functionality.
- Install the camera at a minimum height of 1.5 meters and avoid placing the camera on a table as it may obstruct the AI lens view.
- Keep the camera at least 1.5 meters away from your participants for accurate framing.

Wall Mount Installation

1. Use the drilling paper included in the package to drill the holes in the wall where the user wants to mount the camera.

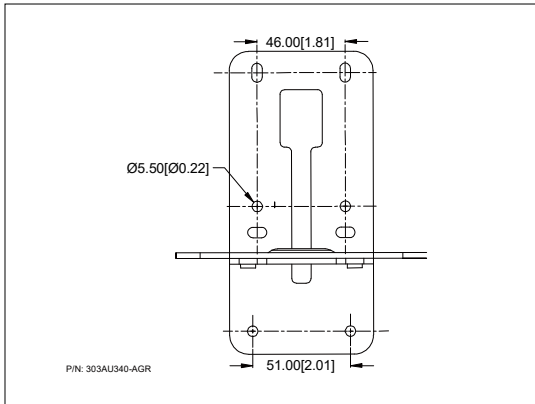

2. Use the screws (not included) to secure the L-mount bracket **A** on the wall.

Screw

For Cement wall: M4 x20mm self-tapping screws (x4) + Plastic conical anchor

For Wooden wall: M4 x20mm self-tapping screws (x4)

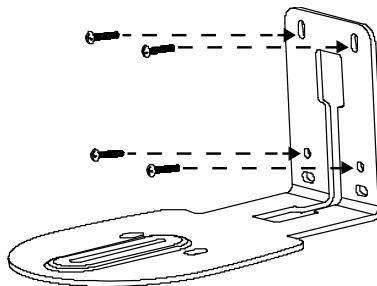

3. Then, assemble the L-mount brackets **A** + **B** with screws (included in package).

Screw size:  M4 x8mm (x2)

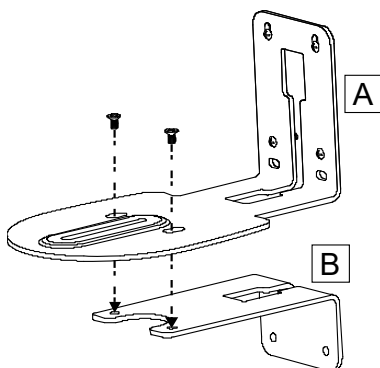

4. After assembling the L-mount brackets, use the screws (not included) to secure the lower part of L-mount brackets on the wall.

Screw

For Cement wall: M4 x20mm self-tapping screws (x2) + Plastic conical anchor

For Wooden wall: M4 x20mm self-tapping screws (x2)

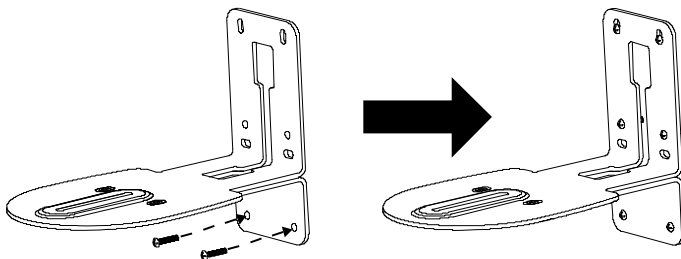

5. Pass the cables through the hole on the L-mount bracket and connect the cables to corresponding connection ports.

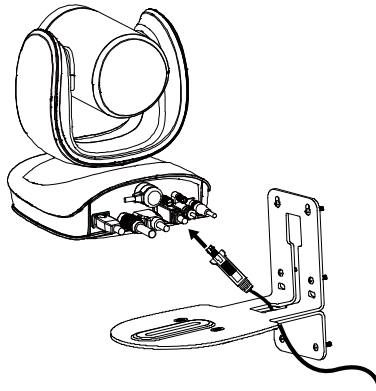

6. Use the remaining screws (included in package) to secure the camera on the L-mount bracket.

Screw:  1/4"-20 L=7.5mm (x2)

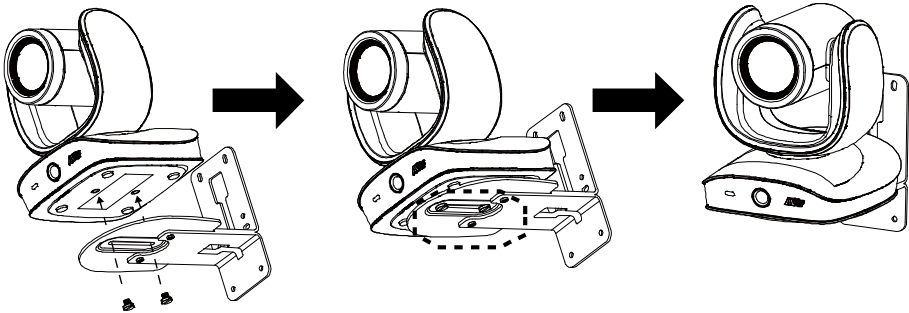

Ceiling Mount Installation (Optional)

Use the ceiling mount bracket to install the camera to the ceiling.

Package Content

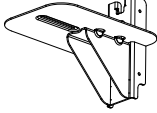
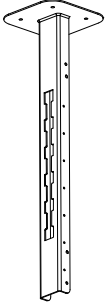

Mount bracket x 1

Camera bracket x 1

Back cover x 1

Screw (M4*8) x 8

Washer x 8

Dimension

Unit=mm

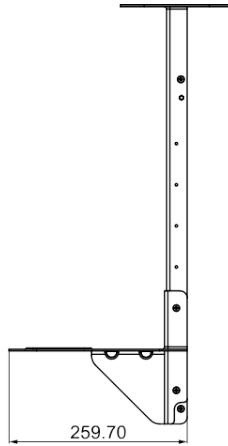
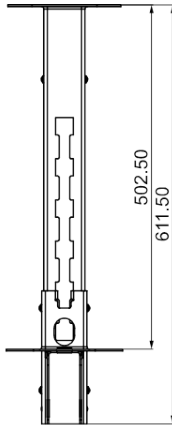
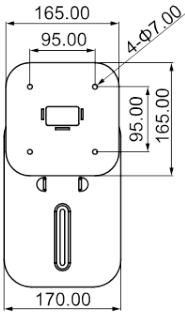

To mount the camera to the ceiling:

1. Drill the hole on the ceiling. Use screw to secure the mount bracket on the ceiling.

Screw: 4 M6 x 50mm (Not included in package)

2. Use the supplied screws with washers to secure the camera bracket to the mount bracket.

Screw: 4 M8 x 4 + 4 Washer

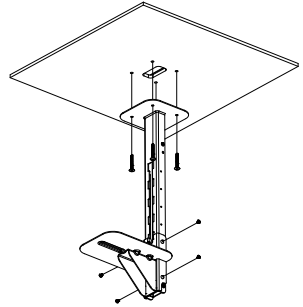

3. Connect all cables on the camera and pass all cables out through the hole on the mount bracket. Then, secure the camera on the camera bracket.

Screw: 2 UNC-1/4"-20 (Not included in package)

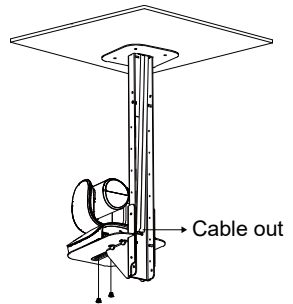

4. Organize all cables to go out from top or bottom of mount bracket.
5. Then, secure the back cover with screws and washer.

Screw: 4 M8 x 4 + 4 Washer

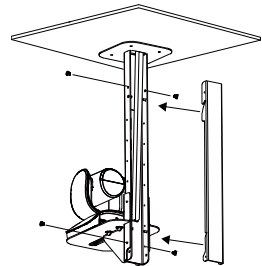

6. Completed.

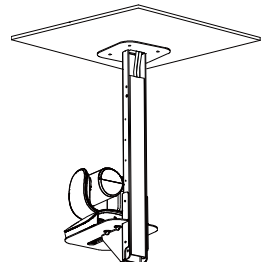

To mount the camera to the calcium silicate ceiling:

1. Please purchase support bracket for supporting camera mount bracket on calcium silicate ceiling. Then, secure the support bracket on the light steel frame structure.
2. Drill the hole on the calcium silicate ceiling. Open a hole on the calcium silicate ceiling to allow camera cables to pass through.
3. Then, secure the mount bracket, calcium silicate ceiling and support bracket together.

Screw: 4 Wingnut + 4 M6x50mm (Not included in package)

4. Use the supplied screws with washers to secure the camera bracket to the mount bracket.

Screw: 4 M8 x 4 + 4 Washer

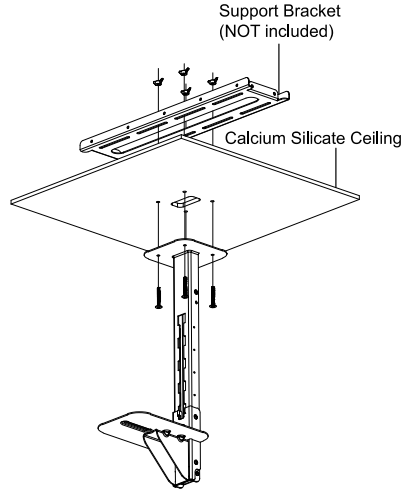

5. Connects all cables on the camera and pass all cables through the hole on the mount bracket. Organize all cables to pass through the hole on the ceiling. Also, the cable can go out from top or bottom of mount bracket.
6. Then, secure the camera on the camera bracket.

Screw: 2 UNC-1/4"-20 (Not included in package)

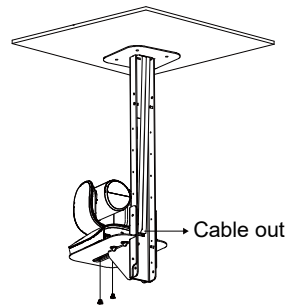

7. Next, secure the back cover with screws and washer.

Screw: 4 M8 x 4 + 4 Washer

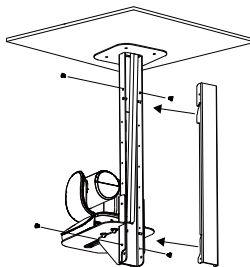

8. Completed.

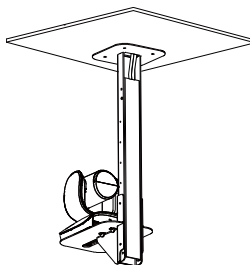

Secure the Cables

Plug in your USB cable or RS-232 cable and tighten the cable screw to secure.

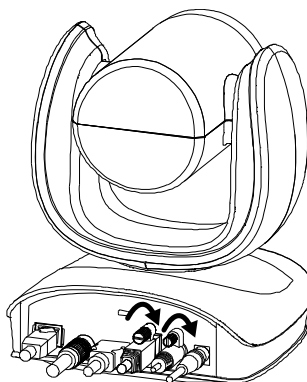

Get Started

Make a Video Call

The CAM570 is a plug-n-play device. Open your video conferencing software and select the CAM570 for **Video**.

Access the Web Interface

To access the web interface of your device, you can use any of the following software to find its IP address:

- AVer Device Utility
- Room Management

Note:

- The default network is DHCP.
- The default username and password is **admin/aver4321**.

AVer Device Utility

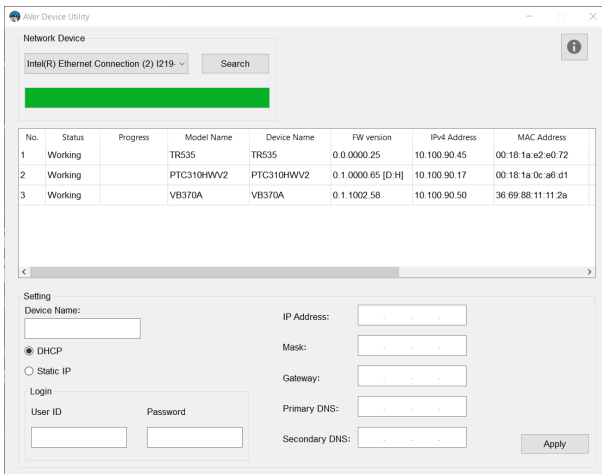

To access the web interface:

1. Download and install AVer Device Utility to your computer from AVer Download Center (<https://www.aver.com/download-center>) and launch the software.
2. Click **Search** to see available devices on the same local area network (LAN).

Note:

- Make sure your device is connected to the internet.
- AVer Device Utility and your device must be on the same LAN.

3. Double-click on your device's IP address in the **IPv4 Address** column to open the web interface in your browser.

To change the network setting to DHCP or static IP:

1. Select the checkbox of your device.
2. Enter the default or changed password in the **Login** field.
3. Select **DHCP** or **Static IP**, then enter your network settings if applicable in the **Settings** section.
4. Click **Apply**.

Room Management

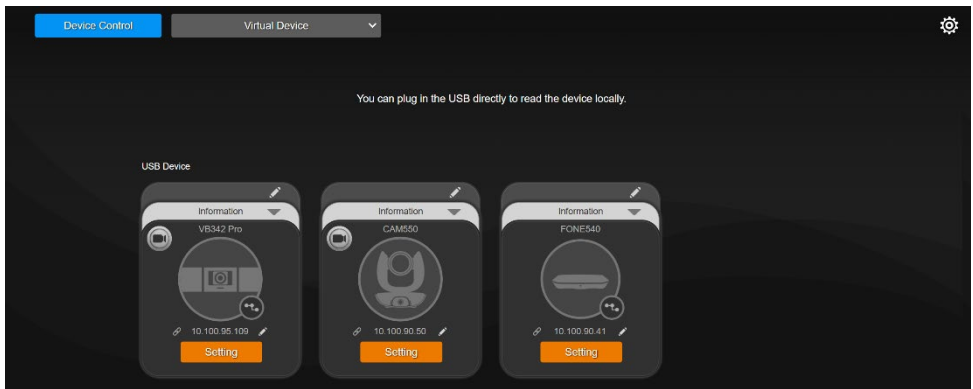

To access the web interface:

1. Download and install Room Management to your computer from AVer Download Center. (<https://www.aver.com/download-center>) and launch the software.

Note:

- Make sure your device is connected to the internet.
- Room Management and your device must be on the same LAN.

2. Connect your device to a computer with the included USB cable. Your device should appear under the **Device Control** page.
3. Click the **hyperlink** icon  on the device card to open the web interface in your browser.

To change the network setting to DHCP or static IP:

1. Click the **pencil** icon  on the device card.
2. Select **DHCP** or **Static IP**, then enter your network settings if applicable.
3. Click **Confirm**.

Log In for the First Time

When you log in for the first time, enter the default password **aver4321**. You will be prompted to set up a new account and password. The account and password cannot be the same.

- Account: Use 1-32 characters.
- Password: Use 8-32 characters and a combination of uppercase letters, lowercase letters, numbers, and symbols (! \$ % ' () * + , - . / < = > ? @ [\] ^ _ { } ~).

Web Interface

PTZ Control

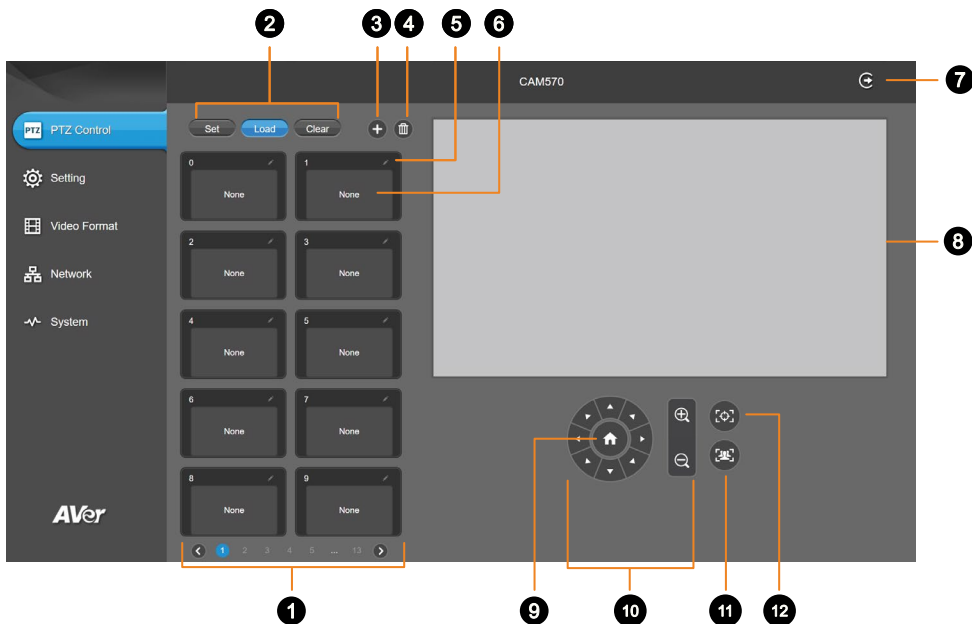

1. Presets 0-9

2. Preset Function Buttons

Save, load and clear a preset.

3. Add Available Presets

There are 10 available presets 0-9 by default. Click the plus icon to add up to 128 available presets.

4. Delete Available Presets

Click a trashcan icon to delete available presets.

5. Name

Click the pencil icon to name a preset.

6. Preset Thumbnail

7. Log Out

Log out of your account and close the web interface.

8. Live View

9. Pan-Tilt Reset

Reset the pan-tilt position to the center.

10. Directional Pad and Zoom

11. SmartFrame

Click the SmartFrame icon  to frame entire group on screen and remove excess space.

Note: The SmartFrame icon  appears on video when turned on. To hide the icon, go to the **Setting** tab > **On-Screen Menu** > **Off** on the web interface.

12. One-Touch Focus

Click to autofocus once.

Save, Load and Clear a Preset



To save a preset:

1. Use the pan, tilt and zoom controls to position your camera.
2. Select **Set**, then a preset number to save that position.
3. Select **Yes** when prompted. A thumbnail of your preset will appear.

Add and Delete Available Presets (Presets 10-127)

There are 10 available presets 0-9 by default.

Click the plus icon to add up to 128 available presets, or click the trashcan icon to delete available presets.

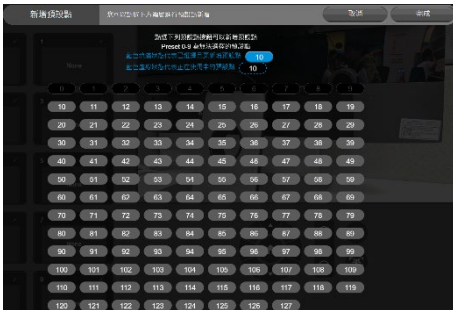

Add

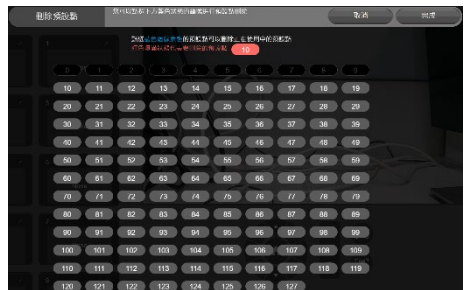

Delete

To add an available presets:

1. Select the plus icon, then select the preset numbers you want to add.
2. Select **Done**.

To delete an available preset:

1. Select the trashcan icon, then select the preset numbers you want to delete.
2. Select **Done**.

Setting

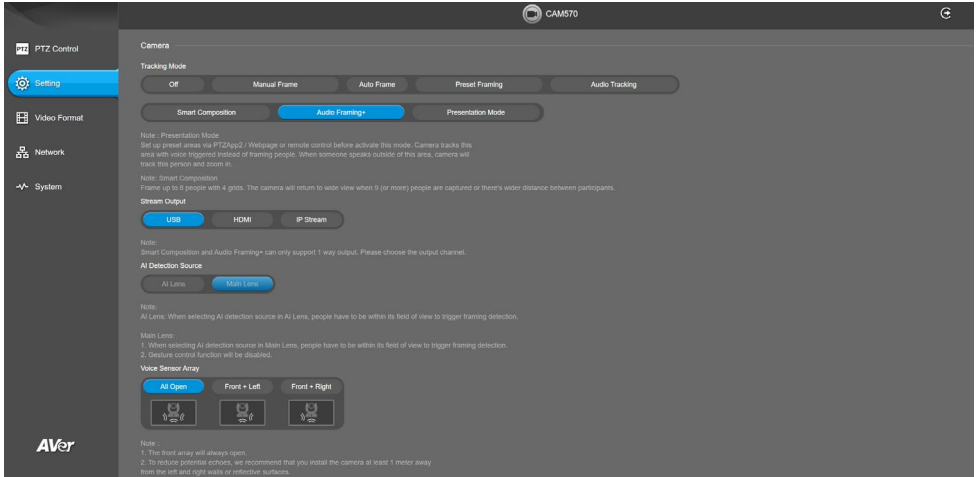

Camera

Item	Description
Tracking Mode	Select a tracking mode. Refer to <Tracking Mode> for details.
Stream Output	Select an output channel under Smart Composition or Audio Framing+ mode.
AI Detection Source	Select a lens to perform for AI detection. The entire group must fit inside the selected lens's field of view.
Voice Sensor Array	Select a voice sensor array.
Camera Moving Speed	Select a camera moving speed.
Framing Speed	Select a duration before auto frame. <ul style="list-style-type: none"> ● Slow: 5 seconds before auto frame. ● Middle: 3 seconds before auto frame. ● High: 1 second before auto frame.
Framing Size	Select a framing size to include or remove excess space on either side of the subject.
Transition Effect	Select a transition effect for Audio Tracking . <ul style="list-style-type: none"> ● PTZ Movement: Use pan-tilt-zoom transition. ● Smart ViewShift: <ul style="list-style-type: none"> - Use dissolve effect, pan-tilt-zoom transition or a mix of both based on the distance of camera travel, to minimize disorienting movements. - Available under Audio Tracking and Presentation Mode. AI lens must be set as AI detection lens. - Smart ViewShift uses only pan-tilt-zoom transition for

	output over 1080p.												
Audio Tracking Response Speed	<p>Select an audio tracking response speed. Slower response speeds can be useful for ignoring short utterances during audio tracking..</p> <ul style="list-style-type: none"> ● Slow Speed: 4 second before audio tracking. ● Middle Speed: 2 seconds before audio tracking. ● High Speed: Fastest audio tracking response speed. 												
Audio Tracking Idle Interval	<p>Select a duration for the camera to frame entire group after it detects no sound. If Off is selected, the camera will stay at the last position.</p>												
Conversation Mode Trigger Sensitivity	<p>Drag the slider to select a sensitivity level with which your camera picks up on a conversation and frame entire group on screen.</p> <table border="1"> <tr> <td>Sensitivity</td> <td>Off</td> <td>1</td> <td>2</td> <td>3</td> <td>4</td> </tr> <tr> <td>Entry</td> <td>Never</td> <td>9th sound source change</td> <td>7th sound source change</td> <td>5th sound source change</td> <td>3rd sound source change</td> </tr> </table>	Sensitivity	Off	1	2	3	4	Entry	Never	9 th sound source change	7 th sound source change	5 th sound source change	3 rd sound source change
Sensitivity	Off	1	2	3	4								
Entry	Never	9 th sound source change	7 th sound source change	5 th sound source change	3 rd sound source change								
Gesture Control	<p>Turn Gesture Control on or off.</p> <ul style="list-style-type: none"> ● AI lens must be set as AI detection lens. ● The effective distance is up to 5 meters. ● Click the question mark icon to see a list of gesture commands or refer to <Gesture Control> for details. 												
Auto Focus	<p>Automatically focus after each pan, tilt and zoom, or automatically focus continually.</p>												
Camera Focus	<p>Adjust the focal length manually by dragging the slider or automatically.</p>												
Home Position	<p>Select the home position that your camera moves to when powered on.</p>												
Sleep Position	<p>Select the home position that your camera moves to when entering standby mode.</p>												
Sleep Timer	<p>Set a duration before standby mode.</p> <ul style="list-style-type: none"> ● When transmitting video over USB, RTSP or RTMP, the camera won't enter standby mode. 												
On Screen Menu	<p>Turn On-Screen Menu on or off.</p> <ul style="list-style-type: none"> ● Load Preset Off: Displays all statuses except load preset. 												
Camera Binding	<p>No setup is required to operate the camera.</p> <ul style="list-style-type: none"> ● When camera binding is turned off (default), all selections on the remote control can operate the camera. ● Or select Camera 1-Camera 3 to assign the camera to a camera select button 1-3 on the remote control. 												
Save Preset	<p>Turn Save Preset on or off.</p> <ul style="list-style-type: none"> ● When Save Preset is turned off, you won't be able to save presets using the remote control, web interface, hotkeys or 												

VISCA commands.

PIP

Item	Description
PIP Layout	Turn on to enable picture-in-picture, then select a screen layout for HDMI or USB/IP output.
HDMI Screen Layout	
USB / IP Streaming Screen Layout	

Image

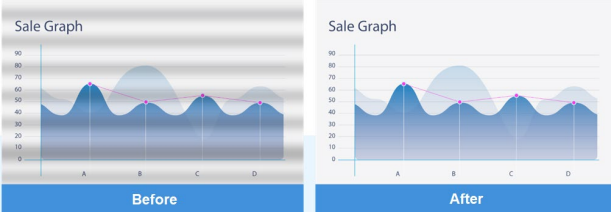
Item	Description
Image Flip	<p>Flip the image vertically.</p> <ul style="list-style-type: none"> When Image Flip is turned on, AI Detection Source will default to the main lens, expecting an upside down installation.
Image Mirror	Flip the image horizontally.
WDR	Turn wide dynamic range (WDR) on or off.
Flicker Decrease on IFP / Monitor	<p>Turn Flicker Decrease on IFP / Monitor on or off.</p> 
Frequency	Select a frequency.
Main Lens 1 / AI Lens 2	Select a lens to set up White Balance , Noise Reduction , Brightness , Sharpness and Saturation . These settings will only apply to the selected lens.
White Balance	<p>Select a white balance setting:</p> <ul style="list-style-type: none"> Manual: Adjust the white balance manually by dragging the slider. Auto: Adjust the white balance automatically.
Noise Reduction	Adjust noise reduction level.
Brightness	Adjust brightness level.
Sharpness	Adjust sharpness level.
Saturation	Adjust saturation level.
Low Light Compensation	Turn Low Light Compensation on or off.
Extended Resolution Options	Select a resolution for extended resolution availability.
Enlarge Total Zoom Up to 36x	Enable or disable Enlarge Total Zoom Up to 36x. The default is

	24X.
Video Frame Rate	Select a video frame rate.

RS-232

Item	Description
ADDR	Select your settings to set up an RS-232 connection.
Baud Rate	
Protocol	
VISCA over IP	

Overview of the Floating Live View

- The floating live views opens automatically in the **Setting** tab.
- To open the floating live view again after closing, click on the camera icon on top of **Setting, Video Format, Network** and **System** tabs.

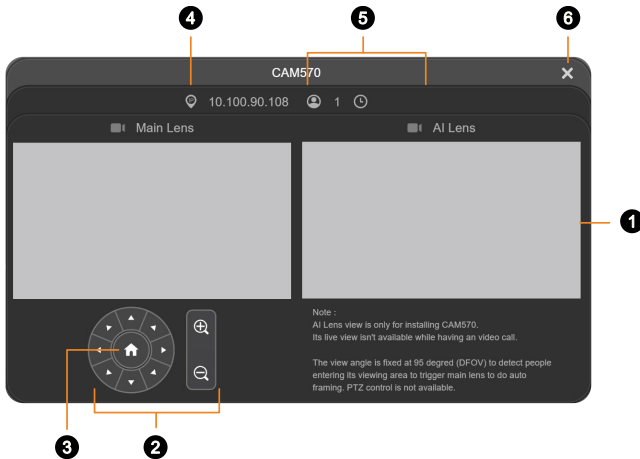

1. Live View

2. Directional Pad and Zoom

3. Pan-Tilt Reset

Reset the pan-tilt position to the center.

4. IP Address

5. Head Count and Video Transmission Duration

Click the head count icon to display head count and the duration of your video transmission. Click the icon again to hide the information.

6. Close

Click the X icon to close the floating live view and stop transmitting video.

Tracking Mode

Manual Frame

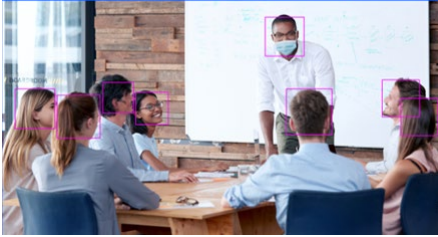

Frames manually using the SmartFrame button  to frame entire group on screen once.

Auto Frame

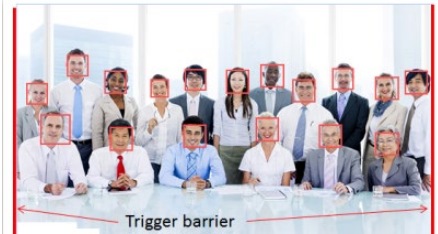

Frames entire group on screen automatically. If no one is in view, the camera will default to preset 0.

- The camera auto frames every time a subject enters or leaves the screen.
- If Auto Frame happens too frequently, set a duration before auto frame in the **Setting** tab > **Framing Speed**.
- You can set either AI lens or main lens as AI detection lens in the **Setting** tab > **AI Detection Lens**.

Preset Framing

Frames the presenter in real time as they move using presets. If no one is within the presets, the camera will default to group framing.

- Make sure you have defined presets. Presets 1-9 are available. Preset 0 defaults to the home position.
- Define overlapping presets for a smooth transition. When the presenter exits the previous preset, the camera will follow and move to the next preset.
- When multiple presenters are within presets, the preset with the smaller number takes priority.

Audio Tracking

Frames active talker on screen.

If no one is speaking, the camera will stay at the last position or default to group framing after your selected **Audio Tracking Idle Interval**.

- You can set a duration before the camera default to group framing in the **Setting** tab > **Audio Tracking Idle Interval**.
- The built-in microphone array is for audio-tracking and cannot be used as an audio source during a video conference. To set up external microphones, download Room Management and go to the **Audio** tab.
- To reduce potential echoes, we recommend that you install the camera at least 1 meter away from the left and right walls or reflective surfaces.

Smart Composition

Frame up to 8 presenters with 4 grids. When there are 9 or more presenters, the camera will zoom out to frame them all.

- In this mode, you can only use the Main Lens. Select the Main Lens as the **AI Detection Source**, and turn off **PIP** (Picture-in-picture) **Layout** in Settings.
- The maximum supported **Video Frame Rate** is 1080P@30Fps.
- Select among USB, HDMI, or IP Stream as the only streaming output channel in **Setting > Stream Output**.

Audio Framing+

Frame one or more active talkers in full screen, PIP layout or 2 grids based on different talking conditions.

- In this mode, you can only use the Main Lens. Select the Main Lens as the **AI Detection Source**, and turn off **PIP** (Picture-in-picture) **Layout** in **Settings**.
- The maximum supported **Video Frame Rate** is 1080P@30Fps.
- Select among USB, HDMI, or IP Stream as the only streaming output channel in **Setting > Stream Output**.

Presentation Mode

A combination of presets (not Preset Framing) and Audio Tracking.

Uses presets when active talker is speaking inside of presets; uses Audio Tracking and frames active talker on screen when they are speaking outside of presets.





If no one is speaking, the camera will stay at the last position or default to group framing after your selected **Audio Tracking Idle Interval**.

- Make sure you have defined presets for audio tracking. Presets 1-9 are available. Preset 0 defaults to the home position.
- You can set a duration before the camera default to group framing in the **Setting** tab > **Audio Tracking Idle Interval**.

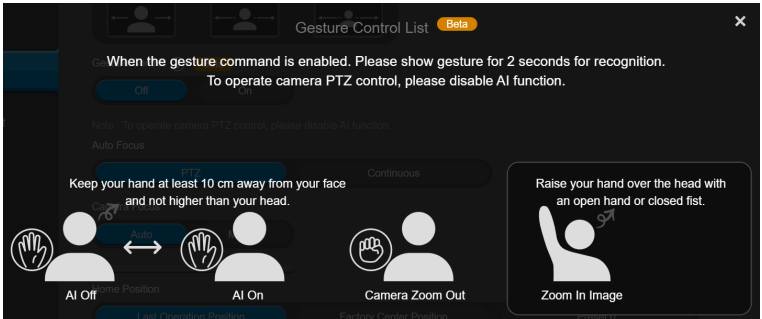
Gesture Control

- Turn on Gesture Control in the **Setting** tab > **Gesture Control**.
- AI lens must be set as AI detection lens. You must be inside the AI lens field of view.
- The effective distance is up to 5 meters.



Gesture	Description
 <p data-bbox="72 794 319 821">Turn Auto Frame on or off</p>	<p data-bbox="352 651 1013 742">Place your hand next to your face with your palm open and facing the camera for 2-3 seconds to turn Auto Frame on or off. Keep your hand 10cm away from your face.</p>
 <p data-bbox="72 992 151 1018">Zoom In</p>	<p data-bbox="352 845 912 869">Raise your hand over your head for 2-3 second to zoom in.</p> <ul data-bbox="352 901 1047 1141" style="list-style-type: none"> • Tracking Mode will be turned off when you zoom in or out with gestures. To turn on Tracking Mode again, do one of the following: <ol style="list-style-type: none"> 1. Use gesture to turn on Auto Frame. 2. Long press the SmartFrame button  on the remote control to switch between tracking modes. 3. Web interface: go to the Setting tab > Tracking Mode. 4. PTAApp 2: go to the Setting tab > Tracking Mode.
 <p data-bbox="72 1295 173 1321">Zoom Out</p>	<p data-bbox="352 1152 1024 1209">Place your fist next to your face with your fist facing the camera for 2-3 seconds to zoom out. Keep your fist 10cm away from your face.</p> <ul data-bbox="352 1241 1047 1481" style="list-style-type: none"> • Tracking Mode will be turned off when you zoom in or out with gestures. To turn on Tracking Mode again, do one of the following: <ol style="list-style-type: none"> 1. Use gesture to turn on Auto Frame. 2. Long press the SmartFrame button  on the remote control to switch between tracking modes. 3. Web interface: go to the Setting tab > Tracking Mode. 4. PTAApp 2: go to the Setting tab > Tracking Mode.

Video Format

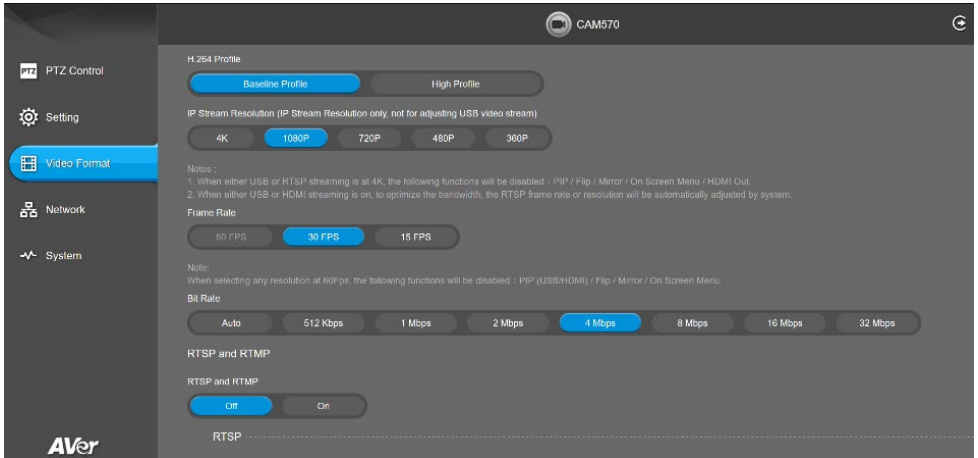

Item	Description
H.264 Profile	Select a profile for streaming live.
IP Stream Resolution	Select a resolution for streaming over IP.
Frame Rate	Select a frame rate.
Bit Rate	Select a bit rate. <ul style="list-style-type: none"> To live stream on Facebook, we recommend a bit rate under 4Mbps.

RTSP and RTMP

Item	Description	
RTSP and RTMP	Turn RTSP and RTMP on or off.	
RTSP	Video Format	Select a video format.
	Require Password	Turn Require Password on or off.
	Set RTSP Access Password	Set or change an RTSP access password.
	URL Address for Main Lens	Displays RTSP URL address for Main Lens.
	URL Address for AI Lens	Displays RTSP URL address for AI Lens. Streaming is not available when Image Flip or Image Mirror is on.
RTMP	Server URL	Copy and paste your video platform's server URL and stream key.
	Stream Key	
	Start Using RTMP	Click Start to start streaming, Stop to stop streaming.

Network

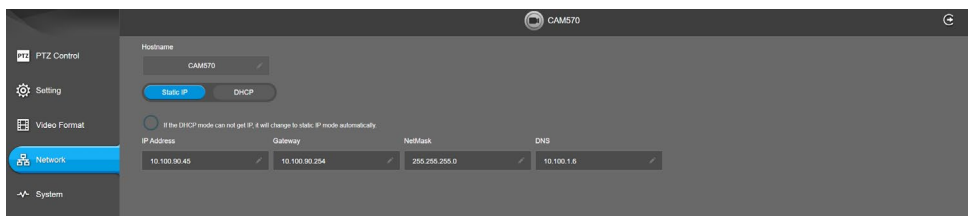

Item	Description
Hostname	Click the pencil icon to edit a hostname. Use upper and lowercase letters and numbers.
Static IP, DHCP	Set up Static IP or DHCP. <ul style="list-style-type: none">● Static IP: Enter your network settings to set up a static IP connection and click Confirm.● DHCP: Check the circle below to switch to Static IP automatically when no IP can be found in DHCP mode. Otherwise, the network will remain in DHCP.

System

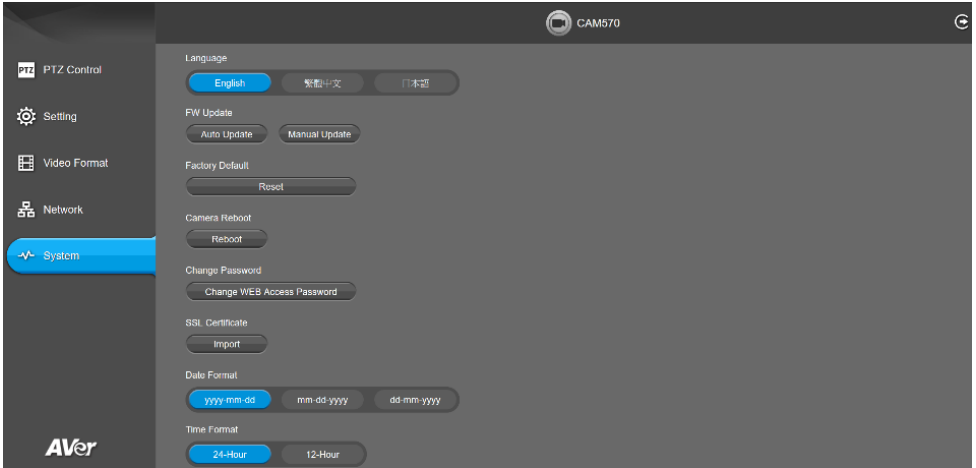

Item	Description
Language	Select a language for the web interface.
Firmware Update	<p>Update your camera's firmware.</p> <ul style="list-style-type: none"> Auto Update: Checks and updates online. Manual Update: Update the firmware using a file offline. <p>Note: The camera will reboot and the connection will be lost. Please wait a few minutes and keep the power cable connected. Unplugging the cable during this process may damage the device.</p>
Factory Default	<p>Reset your camera to factory default settings. You can choose to keep the IP address by selecting the checkmark.</p> <ul style="list-style-type: none"> If you forgot your password, use Room Management to reset the web interface password to the default aver4321.
Camera Reboot	Reboot the camera.
Regular Reboot	Schedule regular reboots to clear RAM and maintain smooth performance. Reboots occur only when no video is streaming.
Next Reboot Time	<ul style="list-style-type: none"> Next Reboot Time: Click the pencil icon to enter a specific reboot time. When finished, click Confirm.
Re-Occur	<ul style="list-style-type: none"> Re-Occur: Select the reboot frequency from the drop-down list. The default setting is to reboot every 3 days.
Supports Schedule Reboot when connected to HDMI	Turn on to enable scheduled reboots when streaming via HDMI.

Change Password	<p>Change the web interface password.</p> <ul style="list-style-type: none"> • Use 8-10 characters and a combination of uppercase letters, lowercase letters, numbers, and symbols (%+=, -_^/@.~). The password cannot be the same as the username. • If you forgot your password, use Room Management to reset the web interface password to the default aver4321.
SSL Certificate	Upload an SSL certificate.
Date Format	Select a date format.
Time Format	Select a time format.
Time Correction Mode	<p>Select a time correction mode.</p> <ul style="list-style-type: none"> • Auto: Enter your Network Time Protocol (NTP) server URL to synchronize the clock. The default NTP server is located in the US. • Manual: Click the pencil icon to set up the clock.
Allow Providing of Anonymous Usage Data	Opt-in or opt-out of providing usage data.
Information	Displays your camera information such as IP address and more.

Room Management

Configure Settings on Room Management

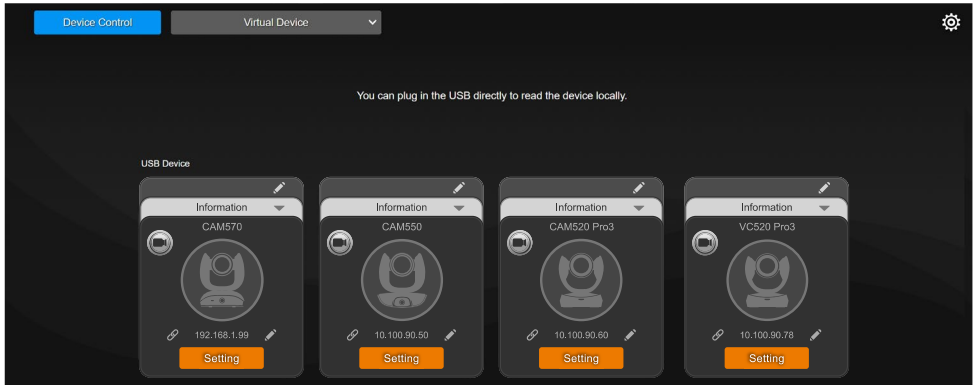

1. Download Room Management from AVer Download Center to your computer and launch the application.
2. Connect your device to your computer using the included USB cable. Your device should appear under the **Device Control** page.
3. Click **Setting** to control audio settings.



Audio Settings

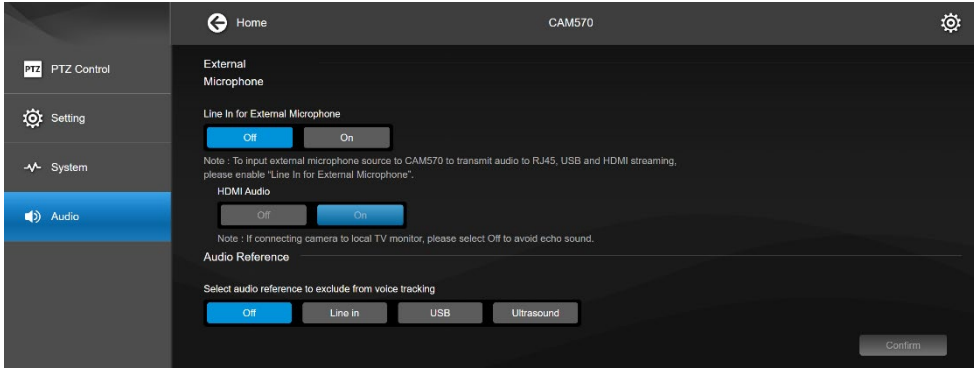

Item	Description
Line In for External Microphone	Turn on to enable the camera to receive audio from the Line In port and transmit this audio via IP, USB and HDMI.
HDMI Audio	<ul style="list-style-type: none"> Using an external microphone alongside HDMI display speakers can cause echo for remote participants. To prevent this, turn off HDMI Audio to mute the local display.
Audio Reference	<p>Select the audio source to be used as a reference signal. The signal tells the camera what to cancel out so it doesn't accidentally track the sound coming from your own speakers.</p> <ul style="list-style-type: none"> Off: No reference signal is used. Select this if voice tracking is not required or if there is no far-end audio. Line in: Filters out the audio signal from the Line In port. USB: Filters out the audio signal returning from a computer via USB. Ultrasound: Filters out audio signal from the FONE540 and FONE700 speakerphones. To use ultrasound: <ol style="list-style-type: none"> Turn on Ultrasound for either speakerphone via the web interface or Room Management. Select Ultrasound as Audio Reference for the camera via Room Management. While playing audio through the speaker, you will see a reception test meter. Red or yellow levels indicate the devices are too far apart or blocked. Adjust the device placement to keep the meter in the green range.

EZLive

Please go to <http://www.aver.com/download-center> to download the AVer EZLive software. After downloading, double-click on the file and follow the on-screen instructions to complete the installation.

During a video call, EZLive can help user to do:

- (1) Camera ePTZ
- (2) Volume control for the speaker connected
- (3) Capture camera's still images
- (4) Record video
- (5) Live stream to Youtube, Livehouse.in, USTREAM...etc.
- (6) Camera Zoom in/out
- (7) Capture PC screen shot
- (8) Record PC screen video
- (9) Set up livestream
- (10) Open file management to retrieve photos and video files
- (11) Livestream setting
- (12) Drawing tool

