

# AI Auto Tracking PTZ Camera

## — User Manual —

TR333V2 / TR323(N)V2 / TR313V2 / TR311HWW2 /  
PTC330UV2 / PTC320U(N)V2 / PTC310UV2 / PTC310HWW2

## Warning

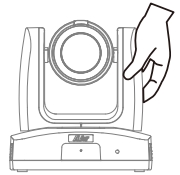
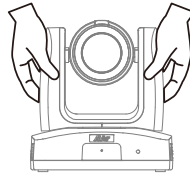
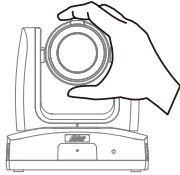
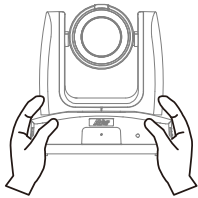

- Hold the bottom of the camera with both hands to carry the camera. Whether the camera is connected to power or not, do not grab any part of the lens or the lens holder to carry the camera or adjust pan and tilt.
- Do not drop the camera or subject it to physical shock.
- Ensure the power supply voltage is correct before using the camera.
- Do not place the camera where the cord can be stepped on as this may result in fraying or damage to the lead or the plug.
- To reduce the risk of fire or electric shock, do not expose the camera to rain or moisture. Warranty will be voided if any unauthorized modifications are done to the camera.

### Federal Communications Commission

NOTE: This equipment has been tested and found to comply with the limits for a Class A digital device, pursuant to part 15 of the FCC Rules. These limits are designed to provide reasonable protection against harmful interference when the equipment is operated in a commercial environment. This equipment generates, uses, and can radiate radiofrequency energy and, if not installed and used in accordance with the instruction manual, may cause harmful interference to radio communications. Operation of this equipment in a residential area is likely to cause harmful interference in which case the user will be required to correct the interference at his own expense.

FCC Caution: Any changes or modifications not expressly approved by the party responsible for compliance could void the user's authority to operate this equipment.

This device complies with part 15 of the FCC Rules.

Operation is subject to the following two conditions:

- (1) This device may not cause harmful interference, and
- (2) this device must accept any interference received, including interference that may cause undesired operation.

This Class A digital apparatus complies with Canadian ICES-003. Cet appareil numérique de la classe A est conforme à la norme NMB-003 du Canada.

## **Warning**

This is a class A product. In a domestic environment, this product may cause radio interference in which case the user may be required to take adequate measures.

## **Caution**

Risk of explosion if battery is replaced by an incorrect type. Dispose of used batteries according to the instructions.

## **PoE**

The PoE+ port is connected only to PoE networks without routing to the outside plant.

## **PSTI Statement of Compliance**

Please refer to the following website: <https://www.aver.com/product-security-advisory>

## **VCCI-A**

この装置は、クラス A 機器です。この装置を住宅環境で使用すると電波妨害を引き起こすことがあります。この場合には使用者が適切な対策を講ずるよう要求されることがあります。

(注)本製品同梱の電源ケーブルは、本製品同梱の電源アダプタでのみ使用してください。本製品同梱の電源ケーブルは、他の電気機器では使用できません。

## **DISCLAIMER**

No warranty or representation, either expressed or implied, is made with respect to the contents of this documentation, its quality, performance, merchantability, or fitness for a particular purpose. Information presented in this documentation has been carefully checked for reliability; however, no responsibility is assumed for inaccuracies. The information contained in this documentation is subject to change without notice.

In no event will AVer Information Inc. be liable for direct, indirect, special, incidental, or consequential damages arising out of the use or inability to use this product or documentation, even if advised of the possibility of such damages.

## **TRADEMARKS**

"AVer" is a trademark owned by AVer Information Inc. Other trademarks used herein for description purpose only belong to each of their companies.

## **COPYRIGHT**

©2025 AVer Information Inc. All rights reserved. | February 5, 2025

All rights of this object belong to AVer Information Inc. Reproduced or transmitted in any form or by any means without the prior written permission of AVer Information Inc. is prohibited. All information or specifications are subject to change without prior notice.

## More Help

For FAQs, technical support, software and user manual download, please visit:

### Non-USA

Download Center: <https://www.aver.com/download-center>

Technical Support: <https://www.aver.com/technical-support>

### USA

Download Center: <https://www.averusa.com/pro-av/support>

Technical Support: <https://averusa.force.com/support/s/contactsupport>

## Contact Information

### Headquarters

AVer Information Inc.  
8F, No.157, Da-An Rd., Tucheng  
Dist., New Taipei City 23673,  
Taiwan  
Tel: +886 (2) 2269 8535

### USA Branch Office

AVer Information Inc., Americas  
44061 Nobel Drive, Fremont, CA  
94538, USA  
Tel: +1 (408) 263 3828  
Toll-free: +1 (877) 528 7824

### Europe Branch Office

AVer Information Europe B.V.  
Westblaak 134, 3012 KM,  
Rotterdam, The Netherlands  
Tel: +31 (0) 10 7600 550

### Japan Branch Office

アバー・インフォメーション株式会社  
〒160-0023 日本東京都新宿区西新宿  
3-2-26 立花新宿ビル 7 階  
Tel: +81 (0) 3 5989 0290  
お客様サポートセンター(固定電話の  
み): +81 (0) 120 008 382

### Vietnam Branch Office

Công ty TNHH AVer Information  
(Việt Nam)  
Tầng 5, 596 Nguyễn Đình Chiểu, P.3,  
Quận 3, Thành phố Hồ Chí Minh  
700000, Việt Nam  
Tel: +84 (0) 28 22 539 211  
Hỗ trợ kỹ thuật: +84 (0) 90 70 080 77

### Korea Office

한국 에버 인포메이션 (주)  
서울시 종로구 새문안로 92  
(신문로 1가,  
광화문오피시아빌딩) 1831,  
1832 호  
Tel: +82 (0) 2 722 8535

# Contents

<b>Warning</b> .....	<b>2</b>
<b>Overview</b> .....	<b>1</b>
Package Contents .....	1
Optional Accessories .....	1
Parts Info .....	2
LED Indicator .....	3
Pan and Tilt Angle .....	3
Dimensions .....	4
Remote Control .....	7
<b>Device Connection</b> .....	<b>7</b>
PoE Connection .....	10
RS-232 Connection .....	11
RS-422 Connection .....	15
Audio Input Connection .....	17
Video Output Connection .....	18
<b>Installation</b> .....	<b>19</b>
Mounting Measurements .....	19
Cable Fixing Plate Installation .....	19
Ceiling Mount Installation .....	20
<b>Set Up the Camera</b> .....	<b>21</b>
OSD Menu .....	21
IP Address Setup .....	21
Static IP .....	21
DHCP .....	22
OSD Menu Tree .....	23
Access the Web Interface .....	26

AVer IPCam Utility .....	26
AVer PTZ Management .....	28
<b>Web Interface .....</b>	<b>29</b>
Live View .....	29
Camera Control .....	29
Preset .....	30
Camera Settings .....	31
Exposure .....	31
Image Process .....	32
Video & Audio .....	33
Network .....	35
Tracking Settings .....	39
Tracking Modes Overview .....	39
Tracking Control Panel .....	40
Presenter Mode .....	41
Zone Mode .....	44
Hybrid Mode .....	47
Gesture .....	50
NDI .....	51
System .....	53
<b>Appendix .....</b>	<b>55</b>
VISCA RS-232 Command Table .....	55
Visca over IP Settings .....	60
CGI Command .....	61
Pelco P Command .....	66
Pelco D Command .....	67

# Overview

## Package Contents

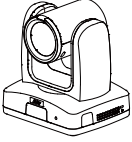

Camera

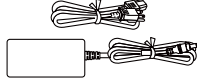

Power Adapter &  
Power Cord



DIN8 to D-Sub9  
Cable



RS-232 In/Out  
Y Cable

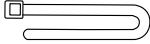

Cable Ties (x4)



Remote Control

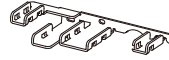

Cable Fixing Plate

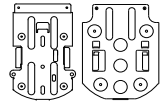

Ceiling Mount Bracket  
(x2)



M2 x 4mm  
Screw (x3)



M3 x 6mm  
Screw (x3)



1/4\"-20, L=6.5mm  
Screw (x2)



Drill Template

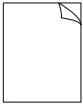

Quick Start Guide

## Optional Accessories



Wall Mount Bracket

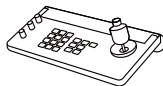

Camera Controller  
(CL01)

\*For detail on optional accessories, consult your local dealer.

# Parts Info

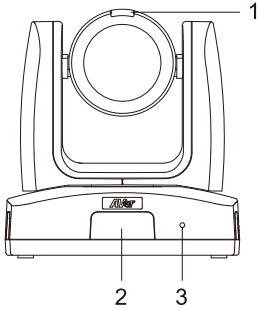

1. Tally Lamp
2. IR Sensor
3. LED Indicator

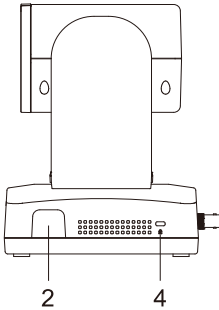

4. Kensington Lock

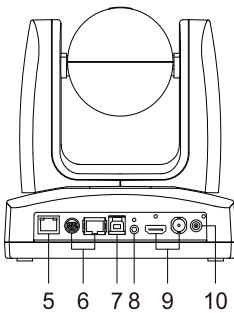

5. PoE+ 802.3at Port
6. Control Ports  
RS-232 / RS-422
7. USB 3.0 Type-B Port
8. Audio In  
Line input level: 1Vrms max.  
Mic input level: 50mVrms max.; supplied voltage: 2.5V.
9. Video Output Ports  
HDMI / 3G-SDI (unavailable for model names with H)
10. DC Power Jack

## LED Indicator

Color	Status
Flashing orange	Start-up
Solid blue	Normal
Solid orange	Standby
Flashing blue	Auto Tracking On
Flashing purple	Gesture recognition
Flashing red	Firmware update

## Pan and Tilt Angle

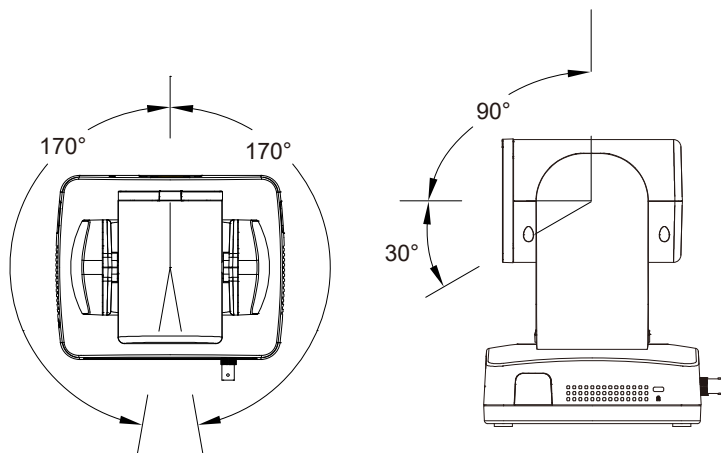

# Dimensions

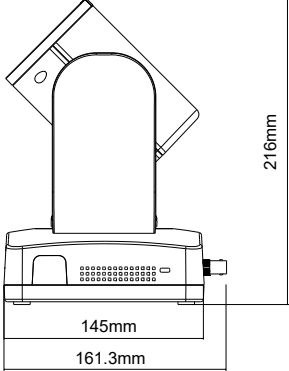
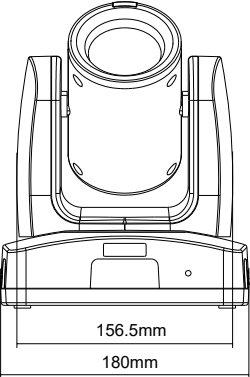
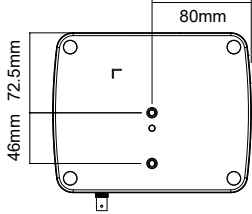
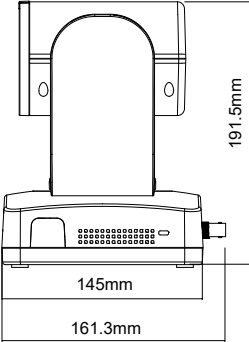
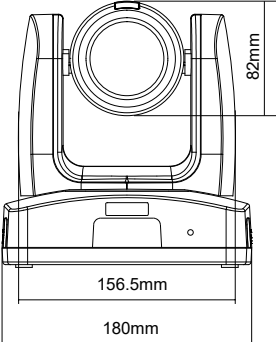

# Ceiling Mount

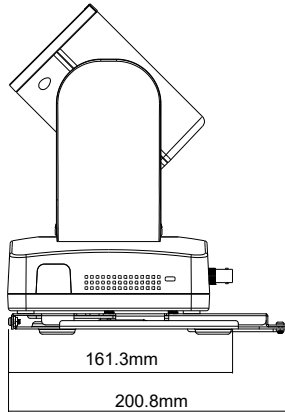
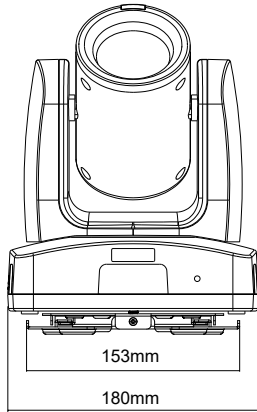
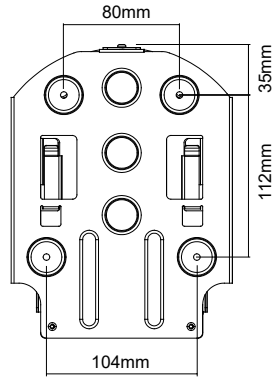
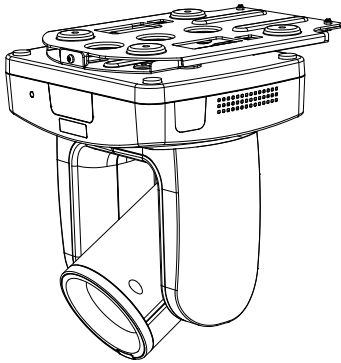

# Wall Mount

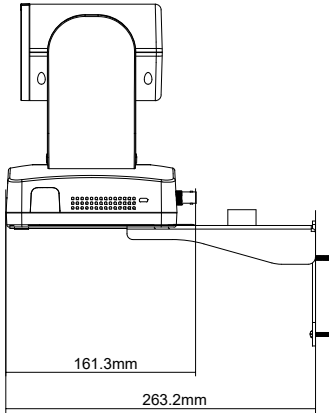
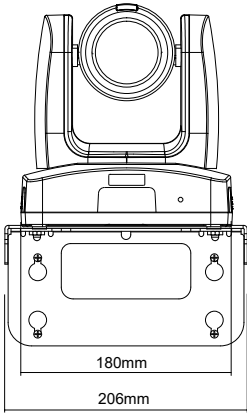
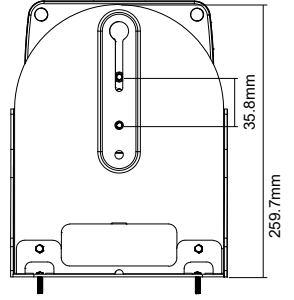
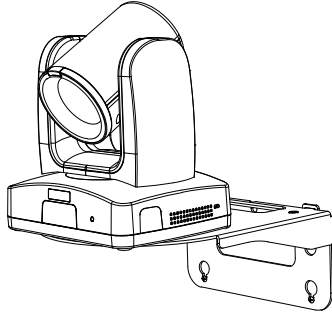
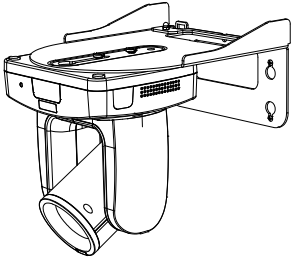

# Remote Control

Your device may come with one of the following remote controls.

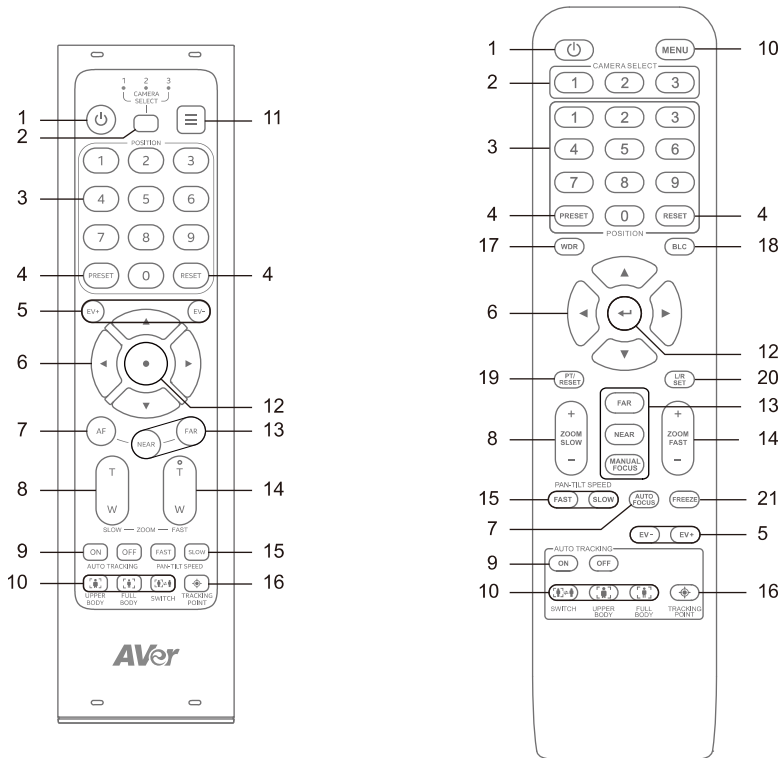

Name	Function
1. POWER	Enter Standby Mode or wake up. <b>Note:</b> Waking up may take a while.
2. CAMERA SELECT	No selection is required to operate the camera by default. <ul style="list-style-type: none"> <li>Both camera and remote control have been set to 1 at the factory.</li> <li>To assign a number to the camera, go to <b>System &gt; Camera Selector</b> in the OSD menu.</li> </ul>
3. NUMBER BUTTONS	Press <b>Number button (0-9)</b> to load defined preset 0-9.
4. PRESET/RESET	<ul style="list-style-type: none"> <li>To save a preset, press and hold <b>PRESET</b>, then press a <b>Number button (0-9)</b>.</li> <li>To clear a preset, press and hold <b>RESET</b>, then press a <b>Number button (0-9)</b>.</li> </ul>
5. EV +/-	<ul style="list-style-type: none"> <li>Press to adjust exposure value.</li> <li>Press and hold <b>EV+</b> to turn on RTMP.</li> </ul>

	<ul style="list-style-type: none"> <li>• Press and hold <b>EV-</b> to turn off RTMP.</li> </ul>
6. PAN-TILT CONTROL	Pan and tilt direction control.
7. AF	Turn on Auto Focus.
8. ZOOM SLOW	Zoom in or out slowly.
9. AUTO TRACKING	Turn Auto Tracking on or off.
10. FRAME PRESENTER	<ul style="list-style-type: none"> <li>• UPPER BODY: Frame presenter's upper body.</li> <li>• FULL BODY: Frame presenter's full body.</li> <li>• SWITCH: Switch presenter.</li> </ul>
11. MENU	Open or close the OSD menu during HDMI output.
12. ENTER	<ul style="list-style-type: none"> <li>• Confirm a selection in the OSD menu.</li> <li>• Press to One Push Focus (auto focus once).</li> </ul>
13. NEAR / FAR / MANUAL FOCUS	Press <b>NEAR</b> or <b>FAR</b> to adjust focus manually. Or press <b>MANUAL FOCUS</b> , if available, to turn on Manual Focus first, then press <b>NEAR</b> or <b>FAR</b> to adjust focus manually.
14. ZOOM FAST	Zoom in or out fast.
15. PAN-TILT SPEED	Adjust pan-tilt speed.
16. TRACKING POINT	Load tracking point (Preset 1).
17. WDR	Turn Wide Dynamic Range on or off.
18. BLC	Turn Backlight Compensation on or off.
19. PT RESET	Reset the pan-tilt position to center.
20. L/R SET	<ul style="list-style-type: none"> <li>• To invert L/R pan direction, press and hold <b>L/R SET</b>, then press <b>Number button 2</b>.</li> <li>• To reset L/R pan direction, press and hold <b>L/R SET</b>, then press <b>Number button 1</b>.</li> </ul>
21. FREEZE	Freeze or unfreeze the live view.

# Device Connection

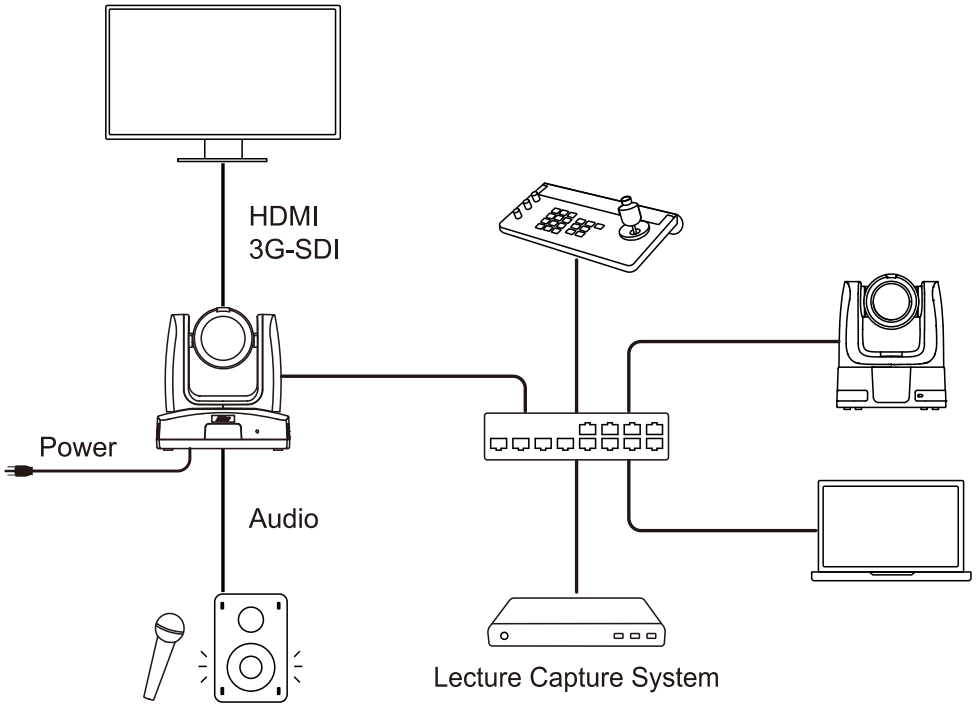

## PoE Connection

Connect the camera to the router or switch through the PoE+ port.

**[Note]** Only support IEEE 802.3AT PoE+ standard.

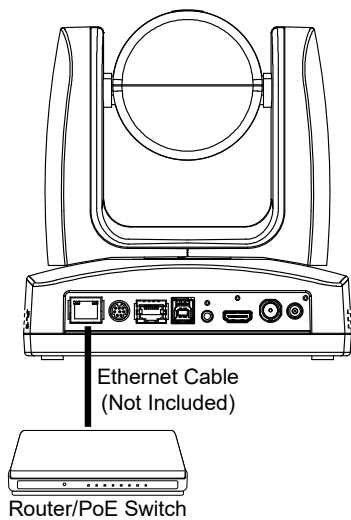

## RS-232 Connection

Connect through the RS-232 or RS-422 for camera control.

- **RS-232**

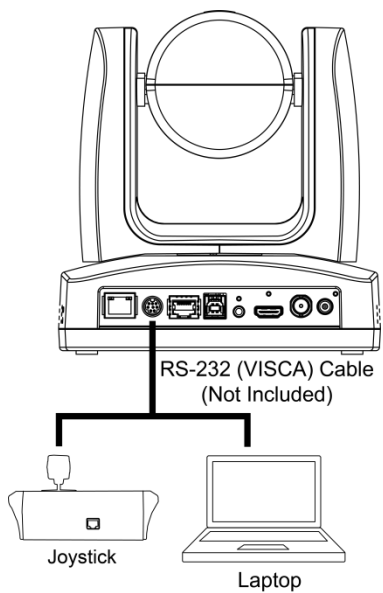

- **RS-232 Port Pin Definition**

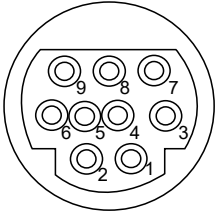

Function	Mini DIN9 Pin #	I/O Type	Signal	Description
VISCA IN	1	Output	DTR	Data Terminal Ready
	2	Input	DSR	Data Set Ready
	3	Output	TXD	Transmit Data
	6	Input	RXD	Receiver Data
VISCA OUT	7	Output	DTR	Data Terminal Ready
	4	Input	DSR	Data Set Ready
	8	Output	TXD	Transmit Data
	9	Input	RXD	Receiver Data
	5	Input	I/O	Detect DIN8/DIN9
---	Shield	---	GND	Ground

● **RS-232 mini DIN9 to mini DIN8 Cable Pin Definition**

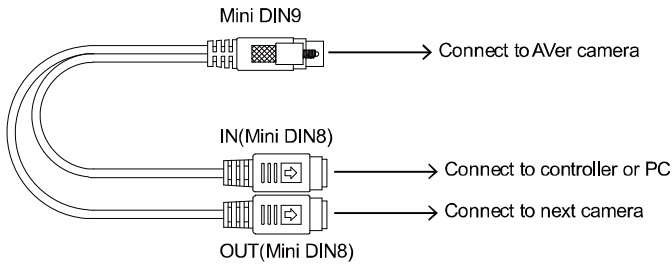

**CIRCUITS:**

B:MD 8P(IN)      A:MD 9M      C:MD 8P(OUT)

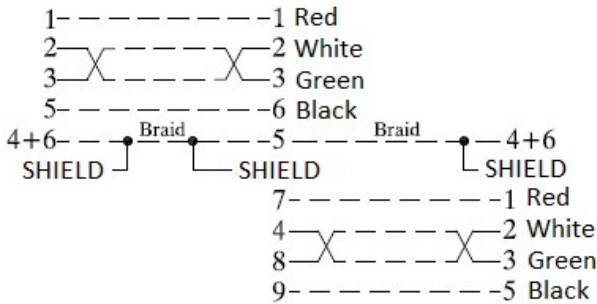

**Mini DIN8 Cable Pin Definition**

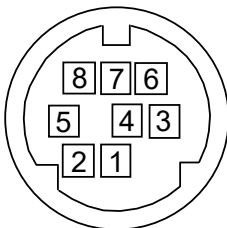

No.	Signal
1	DTR
2	DSR
3	TXD
4	GND
5	RXD
6	GND
7	NC
8	NC

• Din8 to D-Sub9 Cable Pin Definition

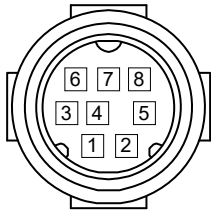
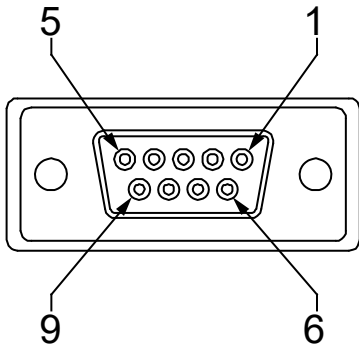

PIN OUT:

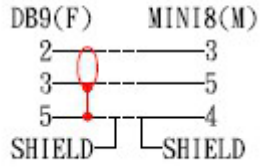

## RS-422 Connection

Use an RS-422 adapter cable to make a RS-422 connection to your control device.

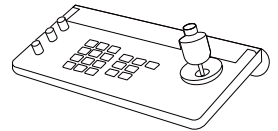
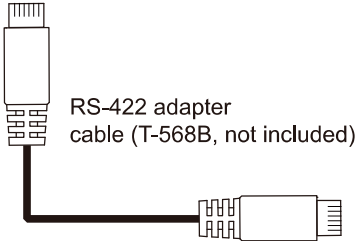
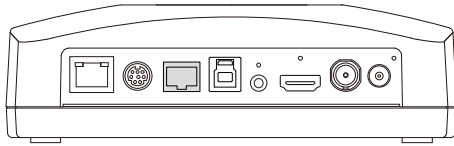
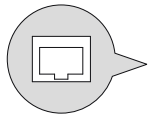

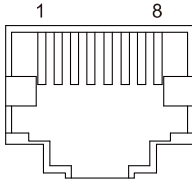

Pin #	Pin
1	TX+
2	TX-
3	RX+
4	TX+
5	TX-
6	RX-
7	RX+
8	RX-

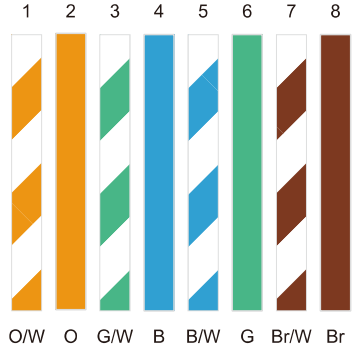

RS-422 Port Pin Definition

T-568B Cable

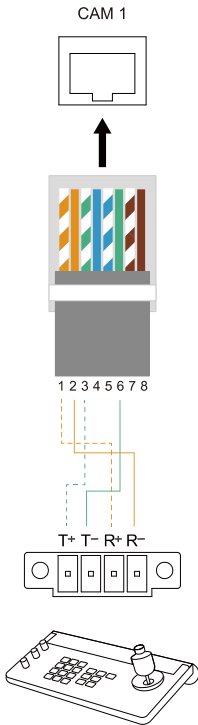

# Audio Input Connection

Connect an audio device to receive audio.

Line input level: 1Vrms (max.).

Mic input level: 50mVrms (max.); Supplied voltage: 2.5V.

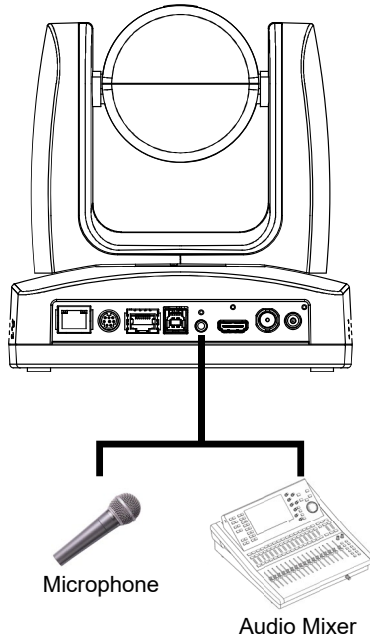

## Video Output Connection

- **HDMI**

Connect to a monitor or TV using an HDMI cable.

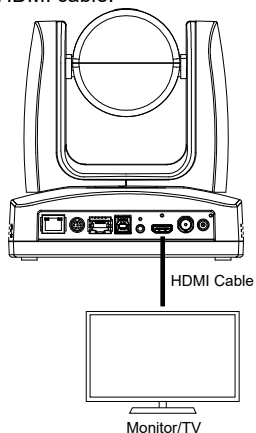

- **3G-SDI**

Connect to a 3G-SDI monitor.

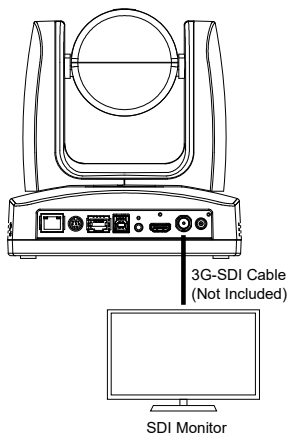

**Note:**

- HDMI and 3G-SDI monitors can be connected to camera and output live video simultaneously. When the HDMI monitor is well connected before the camera is turned on, the OSD menu will be displayed on HDMI monitor as default.
- The model name with "H" do not have 3G-SDI.

# Installation

## Mounting Measurements

- Motion tracking

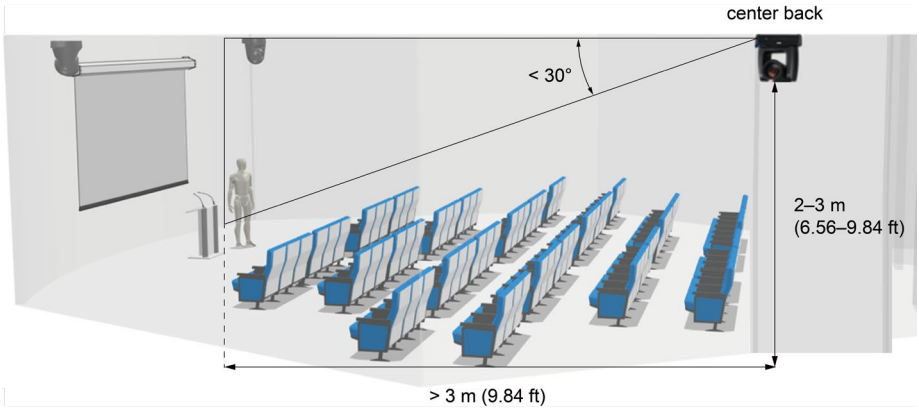

- Voice tracking with third-party microphones

Optical zoom	Distance from subject	Height	Can be inverted
12X	1.6-12 m	1.8-3 m	Yes
21X	2.0-20 m	1.8-3.5 m	Yes
30X	1.8-30 m	1.8-3.8 m	Yes

## Cable Fixing Plate Installation

1. Secure the cable fixing plate to the camera with the included M2 x 4 mm screws (x3).
2. Connect the cables.
3. Use the cable ties to secure the cables to the cable fixing plate.

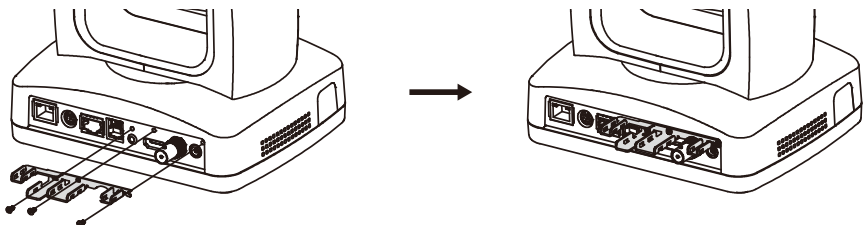

# Ceiling Mount Installation

1. Secure the mount bracket on the ceiling.  
Screw: 4 screws, M4 x 10mm (not Included)

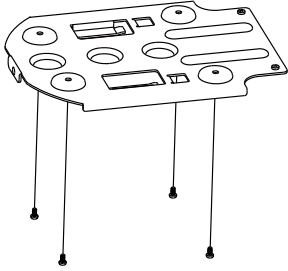

2. Install the mount bracket on the camera.  
Screw: 2 screws, 1/4"-20 L=6.5mm (included)

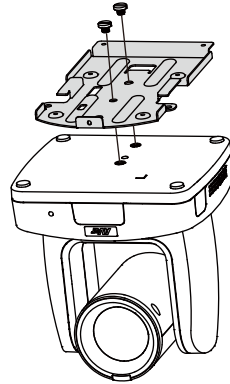

3. Slide the mount bracket with the camera into the mount bracket which secured on the ceiling. And connect the cables.

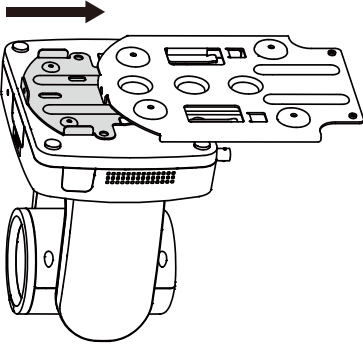

4. Secure the camera with screws.  
Screw: 3 screws, M3 x 6mm (included)

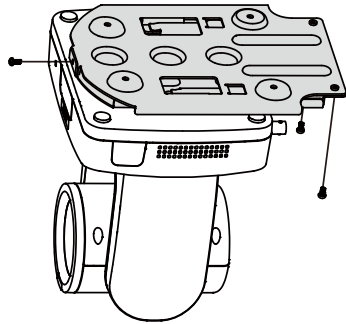

# Set Up the Camera

## OSD Menu

You can use the supplied Remote Control to operate the OSD Menu during HDMI output. Press the **MENU** button to call out the On-Screen Display (OSD) menu and use the **▲**, **▼**, **◀**, **▶** and **↩** buttons to operate the OSD menu.



## IP Address Setup

### Static IP

1. Press the **MENU** button on the remote control to call out the OSD menu.
2. Go to **Network > Static IP**.  
**[Notes]** Turn the DHCP off before setting up static IP (**Network > DHCP > Off**).
3. Select the **IP Address**, **Gateway**, **Netmask** and **DNS** to configure. Press **↩** and use **◀**, **▶** and Number Pad to enter the data.

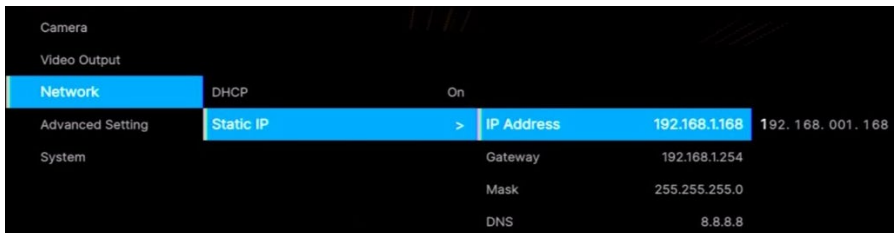

## DHCP

1. Press the **MENU** button on the remote control to call out the OSD menu.
2. Go to **Network > DHCP > On**.



3. After turning the DHCP on, the user can view IP address in **System > Information**.

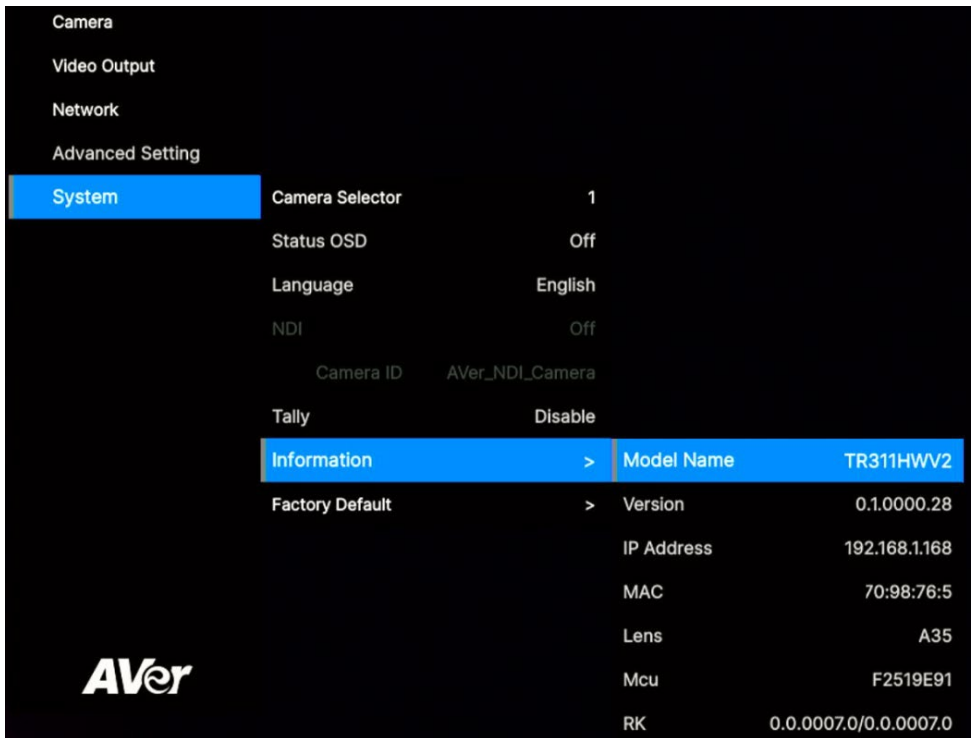

# OSD Menu Tree

1 <sup>st</sup> Layer	2 <sup>nd</sup> Layer	3 <sup>rd</sup> Layer	4 <sup>th</sup> Layer	
Camera	Exposure Mode	Full Auto	Exposure Value	
			Gain Limit Level	
			Slow Shutter	
		Shutter Priority	Exposure Value	
			Shutter Speed	
			Gain Limit Level	
		Iris Priority	Exposure Value	
			Iris Level	
			Gain Limit Level	
			Slow Shutter	
		Manual	Shutter Speed	
			Iris Level	
			Gain Level	
		Bright mode	Bright value	
		White Balance	Auto	
	ATW			
	Indoor			
	Outdoor			
	One push			
	Manual		R gain	
	Pan Tilt Zoom	Preset Speed		5, 25, 50, 100, 150, 200
			Digital Zoom	Off / On
			Digital Zoom Limit	x2, x3, x4, x5, x6, x7, x8, x9, x10, x11, x12
			Pan/Tilt Slow	Off/On
	Noise Reduction	Off / Low / Middle / High		
	Saturation	0-10		
	Contrast	0-4		
	Sharpness	0-3		
	Mirror	Off/On		
	Flip	Off/On		
	LDC	Off/On		

	(Optical zoom 21X, 30X models only)		
Video Output	Priority Mode	2160p (Unavailable for TR311HWV2, PTC310HWV2)	
		1080p	
	Frequency	60	
		59.94	
		50	
	Resolution	2160p30	
		2160p29.97	
		1080p60	
		1080p59.94	
		1080p30	
		1080p29	
		1080I/60	
		1080I/59	
		720p60	
		720p59.94	
		2160p25	
1080p50			
1080p25			
1080I/50			
720p50			
Network	DHCP	Off	
		On	
	Static IP	IP Address	192.168.1.168
		Gateway	192.168.1.254
		Mask	255.255.255.0
DNS		168.95.1.1	
Advanced Setting	Audio	Input Type	Line in / Mic in
		Auto Gain Control	Off/On
		Noise Suppression	Off/Low/Normal
		Audio Volume	0-10
	Control	Serial Port	RS-232/RS-422

		Protocol	VISCA/PELCO D/PELCO P/AW
		Camera Address	1-7
		Baud Rate	4800/9600/38400
	Tracking	Off/On	
	Tracking Mode	Presenter	
		Zone	
		Hybrid	
	Gesture Control	Off	
		Tracking	
		PTZ	
Tracking+PTZ			
System	Camera Selector	1-3	
	Status OSD	Off/On	
	Language	English / 繁體中文 / 日本語 / 简体中文 / 한국어 / Tiếng Việt	
	NDI (NDI model only)	On/Off	
		Camera ID	
	Tally	Disable/Enable	
	Information	Model Name	xxx
		Version	xxx
		IP Address	192.168.1.168
		MAC	xxx
		Lens	xxx
		Mcu	xxx
		RA	xxx
Factory Default	Off/On		
Account Default	Off/On		

# Access the Web Interface

To access the web interface of the camera, you can use any of the following software to find its IP address:

- AVer IPCam Utility
- AVer PTZ Management

**Note:** The camera's default network setting is DHCP.

## AVer IPCam Utility

AVer IPCam Utility v2.7.1029.34

Network Device: Realtek PCIe GbE Family Controller [Search]

Login: User ID [ ] Password [ ]

Network Setting | Date/Time Setting | Maintenance | Import/Export Config

Search Result

No.	Status	Progress	Model Name	Device Name	FW version	IPv4 Address	MAC Address	IPv ^
<input type="checkbox"/> 1	Working		TR535	TR535	0.0000.33	10.100.105.56:80	00:18:1a:00:00:00	[ ]: [ ]
<input type="checkbox"/> 2	Working		TR535	AVer	0.0.0000.06	10.100.105.44:80	00:18:1a:01:02:03	[ ]: [ ]
<input type="checkbox"/> 3	Working		TR535	TR535	0.0.0005.05	10.100.105.91:80	00:18:1a:33:12:99	[ ]: [ ]
<input type="checkbox"/> 4	Working		MD330U	MD330U	1.1.0001.0	10.100.105.71:80	00:18:18:18:54:51	[ ]: [ ]
<input type="checkbox"/> 5	Working		AN-VC22BA	AN-VC22BA	1.1.2030.0	10.100.105.125:80	00:18:1a:09:77:3b	[ ]: [ ]
<input type="checkbox"/> 6	Working		NH720UIS	NH720UIS	1.1.2000.1	10.100.105.17:80	8e:9b:a5:d1:25:0e	[ ]: [ ]
<input type="checkbox"/> 7	Working		AVer	AVer	0.1.0000.00	10.100.105.54:80	00:18:1a:00:00:00	[ ]: [ ]

Settings

Device Name: [ ]

DHCP  
 Static IP

\*Auto search will start after settings changed!  
 Don't start auto search this time!

Start IP Address: [ ] [ ] [ ]  
End IP Address: [ ] [ ] [ ]  
Subnet Mask: [ ] [ ] [ ]  
Gateway: [ ] [ ] [ ]  
Primary DNS: [ ] [ ] [ ]  
Secondary DNS: [ ] [ ] [ ]

[Apply]

### To access the web interface:

1. Download IPCam Utility from AVer Download Center (<https://www.aver.com/download-center>) and launch the software.
2. Click **Search** to see available devices on the same local area network (LAN).

#### Note:

- Make sure your camera has internet.
- IPCam Utility and camera must be on the same LAN.

3. Double-click on your camera's IP address in the **IPv4 Address** column to open the web interface in your browser.

### When you log in for the first time:

Change the username and password before logging in to the web interface.

- Username: Use 1-32 characters.
- Password: Use 8-32 characters and a combination of uppercase letters, lowercase letters, numbers, and symbols (%+=, -\_ ^/ @. ~). The password cannot be the same as the username.

### To change your network to DHCP or static IP:

1. Select the checkbox of your camera.
2. Enter the changed username and password in the **Login** field.
3. Select **DHCP** or **Static IP**, then enter your network settings if applicable in the **Settings** section.
4. Click **Apply**.

# AVer PTZ Management

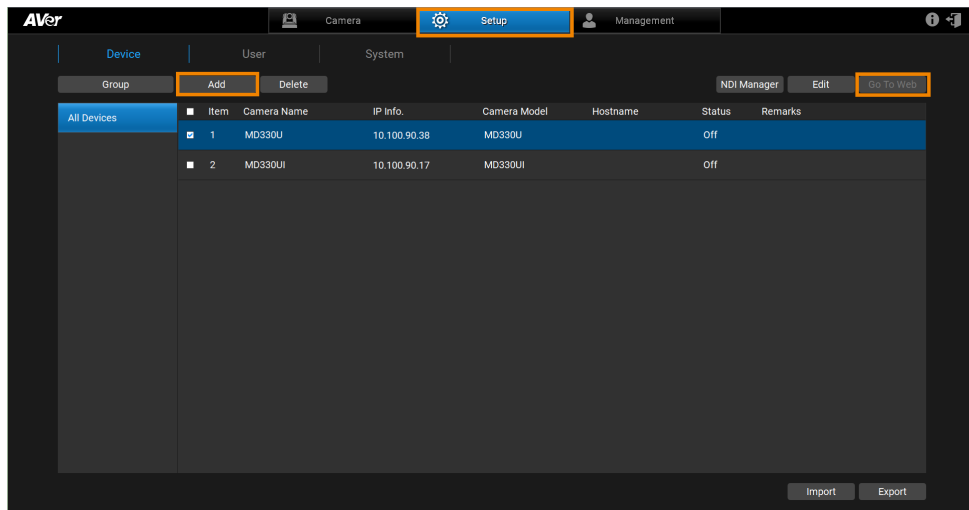

**Note:** The PTZ Management's default username and password is **admin/admin**.

## To access the web interface:

1. Download PTZ Management from AVer Download Center (<https://www.aver.com/download-center>) and launch the software.
2. Log in with the PTZ Management's default username and password **admin/admin**.
3. Go to **Setup > Add**, then click **Auto Search** to see available devices on the same local area network (LAN).
4. Click to select your camera, enter the changed camera username and password, then click **Save** to add the camera to the device list.
5. Select the checkbox of your camera, then click **Go to Web** button to open the web interface in your browser.



# Web Interface

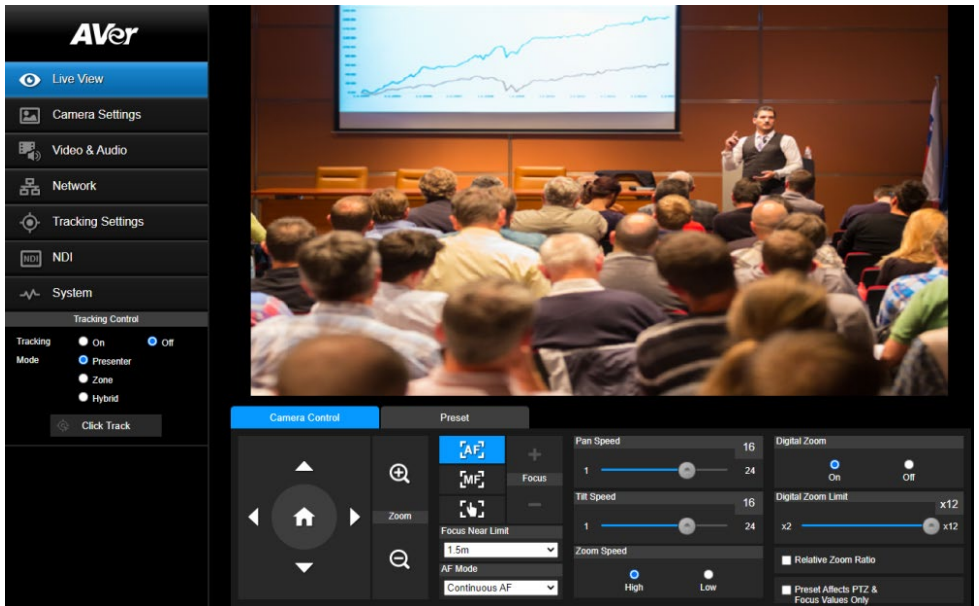

## Live View

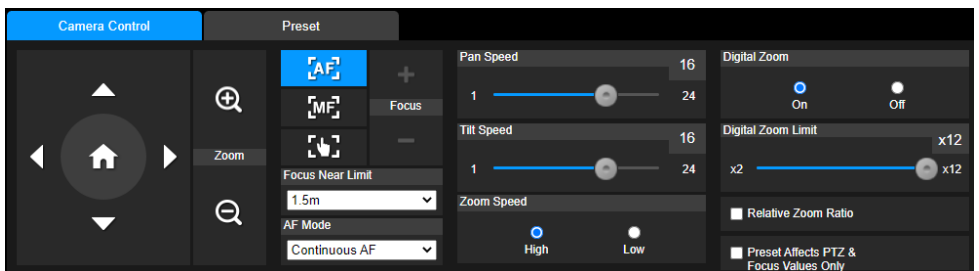

## Camera Control



Item	Description
Pan and Tilt Controls	Position the camera. Drag the slider to adjust <b>Pan Speed</b> and <b>Tilt Speed</b> .
Home Position 	Move the camera to the Home position.
Zoom  	Zoom in or zoom out the live view and select <b>Zoom Speed</b> .

Auto Focus 	Select <b>Auto Focus</b> and then choose an <b>AF mode</b> : <ul style="list-style-type: none"> <li>● <b>AF Trigger after PTZ</b>: Automatically focus after each pan, tilt or zoom.</li> <li>● <b>Continuous AF</b>: Automatically focus continuously.</li> </ul>
Manual Focus 	Click to manually focus. Adjust the focus with + - buttons.
One Push Focus 	Click to automatically focus once.
Focus Near Limit	Set up the nearest focus limit.
Digital Zoom	Turn digital zoom on or off.
Digital Zoom Limit	Adjust the digital zoom.
Relative Zoom Ratio	Select to automatically adjust pan and tilt speeds based on the zoom ratio.
Preset Affects PTZ & Focus Values Only	A preset typically includes pan, tilt, zoom, focus, and 3A (autofocus, autoexposure, auto white balance) values. Select to save only pan, tilt, zoom and focus values for presets.

## Preset

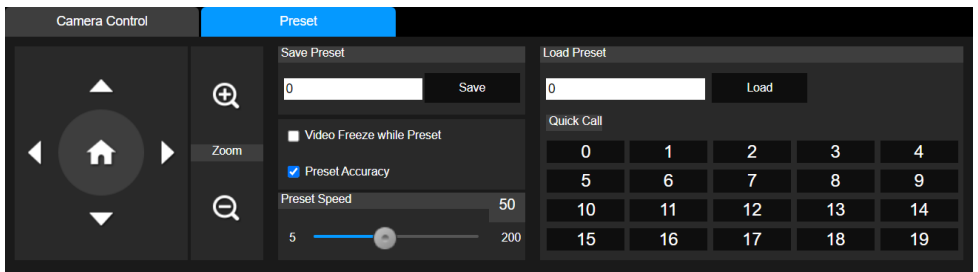

Item	Description
Save Preset	<ol style="list-style-type: none"> <li>1. Position the camera using pan, tilt and zoom controls.</li> <li>2. Enter a preset number (0–255) in the <b>Save Preset</b> field and click <b>Save</b>.</li> </ol>
Load Preset	<ol style="list-style-type: none"> <li>1. Enter a preset number (0–255) in the <b>Load Preset</b> field and click <b>Load</b>.</li> <li>2. Or click a preset number (0–19) in the <b>Quick Call</b> section.</li> </ol>
Video Freeze while Preset	Select to display only the live view from presets. The live view from the moving path will not be displayed.
Preset Accuracy	Select to improve the accuracy of moving to presets.
Preset Speed	Adjust the camera speed when moving to presets.

# Camera Settings

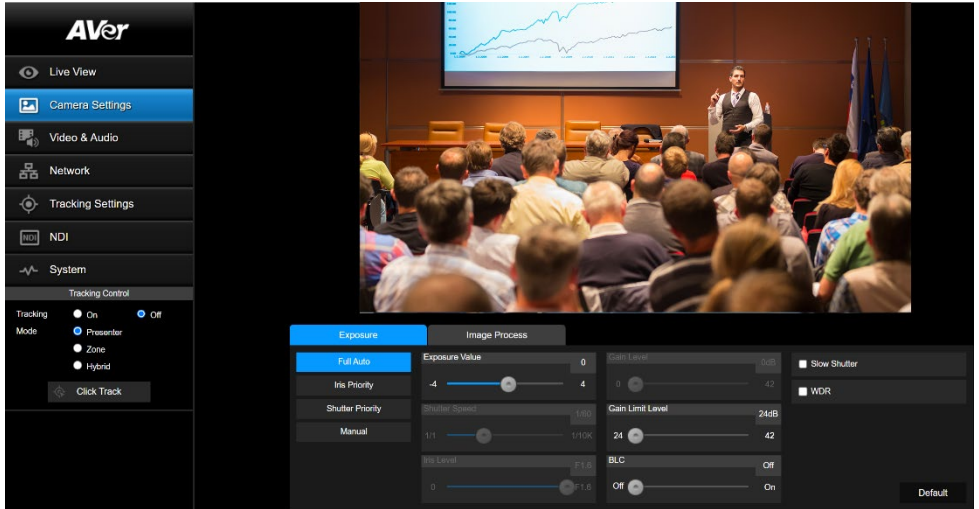

## Exposure

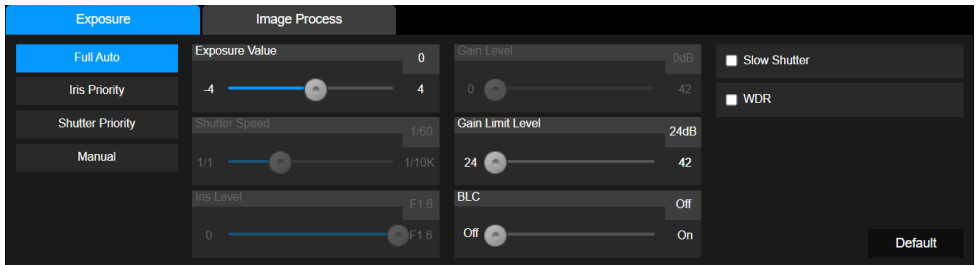

**Note:** Click **Default** to reset Exposure to factory default settings.

Item	Description
Exposure Mode	Choose an exposure mode.
Exposure Value	Adjust exposure, shutter, iris and gain.
Shutter Speed	
Iris Level	
Gain Level	
Gain Limit Level	Turn backlight compensation (BLC), slow shutter, wide dynamic
BLC	

Slow Shutter	range (WDR) on or off.
WDR	

## Image Process

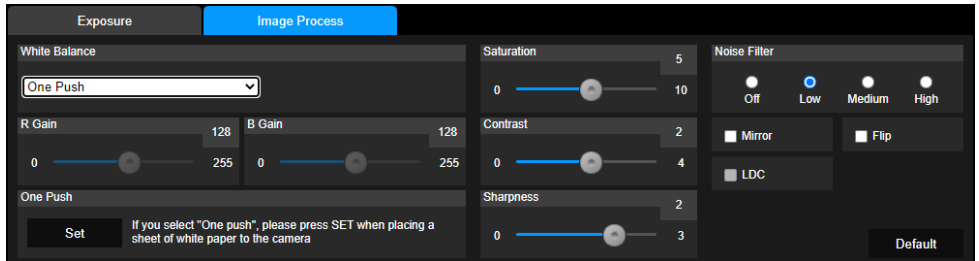

**Note:** Click **Default** to reset Image Process to factory default settings.

Item	Description
White Balance	Choose a white balance mode <ul style="list-style-type: none"> <li>In <b>Manual</b> mode, you can also adjust the <b>R Gain</b> and <b>B Gain</b>.</li> <li>In <b>One Push</b> mode, place a piece of white paper in front of the camera lens and click <b>Set</b> to calibrate white balance.</li> </ul>
Saturation	Adjust saturation, contrast and sharpness.
Contrast	
Sharpness	
Noise Filter	Select a noise filtering level.
Mirror	Select the checkbox to flip the image horizontally.
Flip	Select the checkbox to flip the image vertically.
LDC (Optical zoom 21X, 30X models only)	Select the checkbox to turn on lens distortion correction.

# Video & Audio

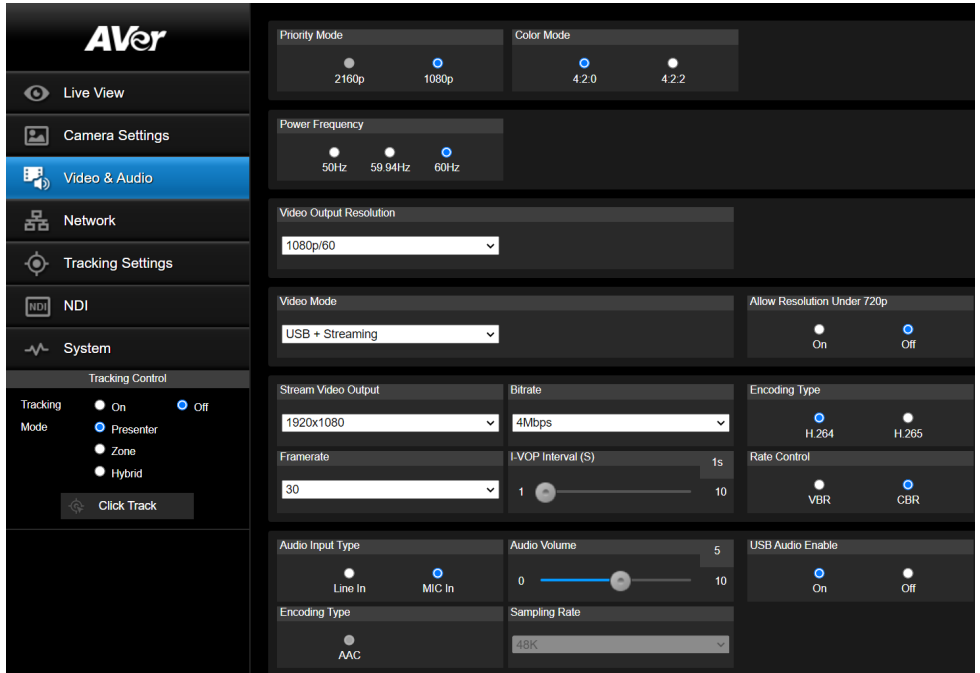

Item	Description
Priority Mode	Select 2160p or 1080p. <ul style="list-style-type: none"> <li>2160p is available for 4K models only, unavailable for TR311HWV2, PTC310HWV2.</li> </ul>
Color Mode	Select a color mode for video. <ul style="list-style-type: none"> <li>4:2:0: Recommended for 3G-SDI.</li> <li>4:2:2: Recommended for HDMI.</li> </ul>
Power Frequency	Select <b>50Hz</b> , <b>59.94Hz</b> or <b>60Hz</b> based on your country and region.
Video Output Resolution	Select a resolution for video output.
Video Mode	Select a video mode according to the output interface you use. <ul style="list-style-type: none"> <li>If you don't see NDI mode, you may need to activate an NDI license.</li> </ul>
Allow Resolution Under 720p	Select <b>On</b> to allow transferring lower resolution video streaming when working with some video conference software such as Teams. It's recommended to select <b>Off</b> if you want to keep better image quality during video call.
Stream Video Output	Select a stream resolution for live view.
Bitrate	Select a bit rate.

Encoding Type (video)	Select <b>H.264</b> or <b>H.265</b> .
Framerate	Select a framerate.
I-VOP Interval (S)	Drag the slider to set the value from <b>1s</b> to <b>10s</b> .
Rate Control	Select <b>VBR</b> or <b>CBR</b> .
Audio Input Type	Select to input audio by <b>Line in</b> or <b>Mic in</b> .
Audio Volume	Drag the slider to set the volume from <b>0</b> to <b>10</b> .
USB Audio Enable	Select from the drop-down list to turn on or off the setting.
Encoding Type (audio)	AAC
Sampling Rate	Select a sampling rate.

# Network

**AVer**

**Network**

**DHCP**  
 On  Off

**Hostname**  
AVer

**NTP**  
 On  Off

**IP Address**  
10.100.90.21

**Netmask**  
255.255.255.0

**NTP Server**  
pool.ntp.org

**Gateway**  
10.100.90.254

**DNS**  
198.95.1.1

Confirm

**RTMP Settings**  
Server URL  
Stream Key  
Start Stream STOP

**RTSP Security**  
 On  Off

**RTSP Audio Enable**  
 On  Off

**HLS Settings**  
Stream URL  
Start Stream STOP

**SRT Settings**  
Destination IP Port Encryption  
1000 ms 8880 None  
Latency Passphrase  
Connect Status: Disconnected Start Stream STOP

**HTTPS**  
 Only  On  Off

**Upload Certificate**  
Choose File No file...hosen Upload

**SSHD**  
 On  Off

**Visca Port Mode**  
Default

**Visca Port Number**  
Port 82381 Save

**802.1x Enable**  
 On  Off

**Eap Method**  
 MD5  TLS  PEAP

**Eap Setting**  
Identity Password

**Client Certificate**  
Import Choose File No file...hosen Upload Private Key Password

**CA Certificate**  
Import Choose File No file...hosen Upload Confirm

**Freed**  
 On  Off

**Camera ID**  
355

**IP Address**  
192.168.1.168

**Port**  
80000

Confirm

Item	Description
DHCP	Set up the network to DHCP or Static IP. <ul style="list-style-type: none"> <li>• <b>DHCP</b>: Select <b>On</b> to assign the related IP settings with the camera automatically. Click <b>Confirm</b> to save the settings.</li> <li>• <b>Static IP</b>: Select <b>Off</b> to manually enter the <b>IP Address</b>, <b>Netmask</b>, <b>Gateway</b> and <b>DNS</b>. Click <b>Confirm</b> to save the settings.</li> </ul>
Hostname	Enter a hostname that is displayed on devices such as an IP router. <ul style="list-style-type: none"> <li>• The default is AVer.</li> </ul>
NTP	Turn Network Time Protocol (NTP) on or off.
RTMP Settings	Stream live video to a video platform such as YouTube. <ol style="list-style-type: none"> <li>1. Enter the <b>Server URL</b> and <b>Stream Key</b> of your video platform. Please refer to the instruction of your platform to obtain the server URL and stream key.</li> <li>2. Click <b>Start Stream</b> to start streaming, <b>Stop</b> to stop streaming.</li> </ol>
RTSP Security	Protect your video stream on media players such as VLC, PotPlayer and QuickTime by ensuring that only authorized users can access it. <ul style="list-style-type: none"> <li>• When <b>Security</b> is turned off:               <ol style="list-style-type: none"> <li>1. Enter your camera's RTSP URL into the media player.</li> <li>2. RTSP URL: rtsp://[camera IP address]/live_st1 Example: rtsp://192.168.1.100/live_st1</li> </ol> </li> <li>• When <b>Security</b> is turned on:               <ol style="list-style-type: none"> <li>1. Enter your camera's RTSP URL, username and password into the media player.</li> <li>2. RTSP URL: rtsp://[username:password]@[camera IP address]/live_st1 Example: rtsp://1:1@192.168.1.100/live_st1</li> <li>3. Username and password: camera's web interface login</li> </ol> </li> </ul>
RTSP Audio Enable	Turn on to stream audio.
HLS Settings	Configure HTTP Live Streaming (HLS) settings to provide adaptive bitrate streaming, which ensures smooth playback and minimizes buffering. <ol style="list-style-type: none"> <li>1. Enter the stream URL obtained from the streaming service or server.</li> <li>2. Click <b>Start Stream</b> to start streaming, <b>Stop</b> to stop streaming.</li> </ol>
SRT Settings	<ul style="list-style-type: none"> <li>• vMix               <ol style="list-style-type: none"> <li>1. Make sure the vMix workstation and your camera are on same network. Copy the workstation's IP address.</li> </ol> </li> </ul>

```

C:\WINDOWS\system32\cmd.exe
Windows IP Configuration

Wireless LAN adapter Local Area Connection* 1:

    Media State . . . . . : Media disconnected
    Connection-specific DNS Suffix  . :

Ethernet adapter Ethernet:

    Connection-specific DNS Suffix  . :
    Link-local IPv6 Address . . . . . : fe80::8013:bd79:8b8c:2339%21
    IPv4 Address. . . . . : 192.168.1.10
    Subnet Mask . . . . . : 255.255.255.0
    Default Gateway . . . . . :

Wireless LAN adapter Wi-Fi:

    Connection-specific DNS Suffix  . : aver.com
    Link-local IPv6 Address . . . . . : fe80::685d:6272:1f05:a46e%11
    IPv4 Address. . . . . : 10.100.200.67
    Subnet Mask . . . . . : 255.255.255.0
    Default Gateway . . . . . : 10.100.200.254

Ethernet adapter Bluetooth Network Connection:

```

2. Go to **Stream** tab > select **SRT (Listener)** from the **Stream Type** drop-down list. Copy the **Port** value.

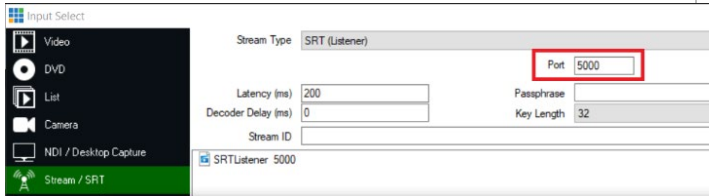

3. Paste the IP address and Port value into **SRT Settings** fields and click **Start Stream**. **Connect Status** will change to **Connected**.

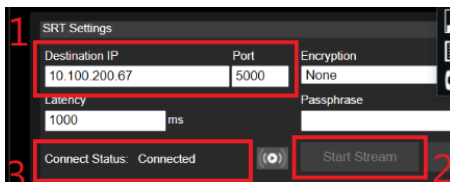

- **OBS (Open Broadcaster Software)**
  1. Make sure the OBS workstation and your camera are on same network. Copy the workstation's IP address.

```

Connection-specific DNS Suffix . : aver.com
Link-local IPv6 Address . . . . . : fe80::f1dc:b0da:87bd:acle%
IPv4 Address. . . . . : 10.100.105.127
Subnet Mask . . . . . : 255.255.255.0
Default Gateway . . . . . : 10.100.105.254

```

2. Open OBS. Add a scene and a source.
3. Enter "srt://[Workstation IP]:[port]?mode=listener" in the **Input** field.  
Example: srt://10.100.105.127:8889?mode=listener

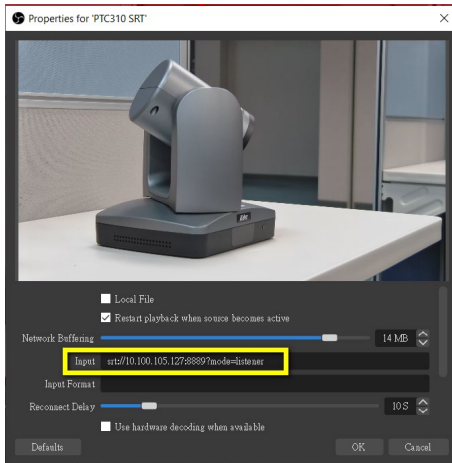

4. If there is no image, right-click on the source > **Transform** > **Fit to screen** to re-scale image.

HTTPS	<p>Enable HTTPS to establish a secure connection between your browser and your camera. To enable HTTPS access on your camera:</p> <ol style="list-style-type: none"> <li>1. Obtain a SSL certificate for encryption and decryption in base-64 encoded format and use a private key in PKCS#8 format (unencrypted).</li> <li>2. Package the required certificate content into PEM format. The SSL certificate uploaded to the camera must be in PEM format.</li> <li>3. Click <b>Choose File</b> to select the certificate file, and then click <b>Upload</b>.</li> <li>4. Turn on HTTPS.</li> </ol>
SSHD	Turn remote debugging from AVer on or off.
Visca Port Mode	Select a VISCA port mode.
Visca Port Number	Enter a VISCA port number.
802.1x Enable	Turn 802.1x Enable on or off.
Eap Method	When <b>802.1x Enable</b> is turned on, select an Eap method.
Eap Setting	Based on your Eap method, complete the authentication and click <b>Confirm</b> .

# Tracking Settings

## Tracking Modes Overview

For details on settings, please refer to their respective chapters.

### Presenter

Frames and follows the presenter on screen.



### Zone

Frames and follows the presenter on screen using up to four presets. When the presenter exits the previous preset, the camera will follow and move to the next preset.



### Hybrid

Hybrid Mode combines Presenter Mode and Zone Mode.

Uses presets when the presenter is inside of presets, frames and follows the presenter when they are outside of presets.



## Tracking Control Panel

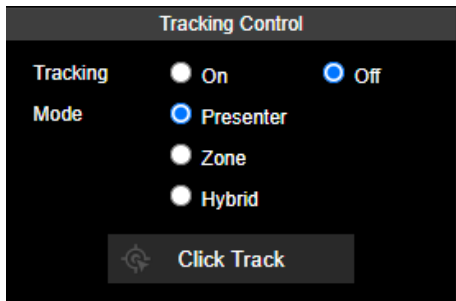

- **Tracking:** Turn tracking on or off.
- **Mode:** Select a tracking mode to frame and follow the presenter in real time as they move. For details on tracking settings, please refer to respective chapters.
- **Click Track:** Presenter Mode lets you switch the presenter you want to track. Click the **Click Track** button to frame everyone on screen in bounding boxes and click to select the presenter you want to track. Selected presenter will be in a red frame.



# Presenter Mode

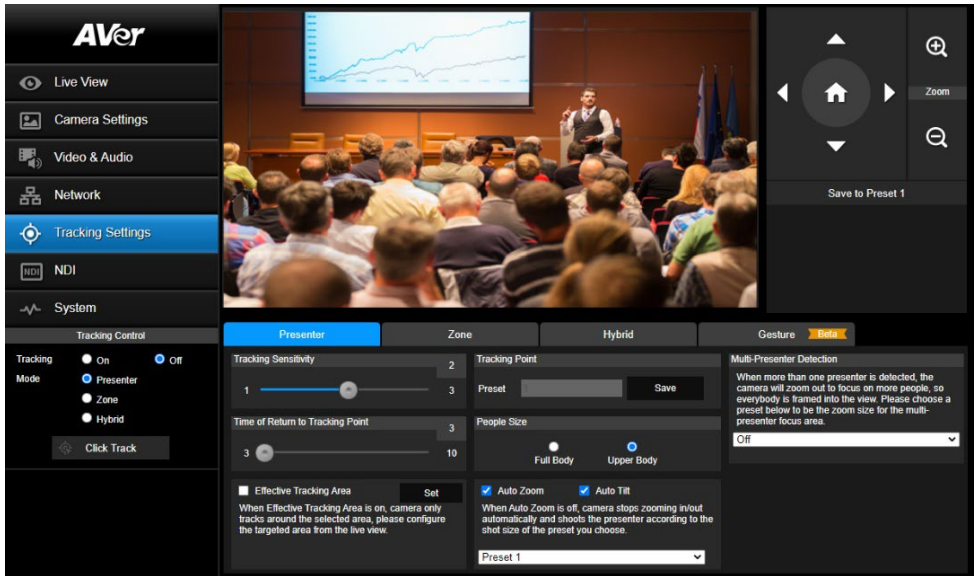

Presenter Mode frames and follows the presenter on screen, and returns to the tracking point (Preset 1) when no one is on screen.

## To set up Presenter Mode:

1. Go to **Tracking Settings > Presenter**.
2. Use pan, tilt and zoom controls to position your camera and click **Save to Preset 1** to save the **Tracking Point**.
3. Configure additional settings:

Item	Description
Tracking Sensitivity	Drag the slider to adjust tracking sensitivity.
Time of Return to Tracking Point	Drag the slider to set an idle time (second) before the camera return to the tracking point.
Effective Tracking Area	Define an effective tracking area. The camera only tracks the presenter inside that area. <ol style="list-style-type: none"> <li>1. Select the checkbox and click <b>Set</b>.</li> <li>2. Drag the upper-left or the lower-right corner of the red square to adjust the size of the tracking area.</li> </ol>
Tracking Point	If no one is on screen, the camera will return to the tracking point (Preset 1).

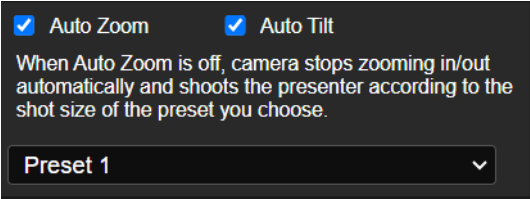
People Size	Frame the presenter's full body or upper body.
Auto Zoom	<ul style="list-style-type: none"> <li>When <b>Auto Zoom</b> is turned off, the zoom ratio will be based on your selected preset from the drop-down list.</li> <li>When <b>Auto Tilt</b> is turned off, the tilt angle will be based on your selected preset from the drop-down list.</li> </ul>
Auto Tilt	
Multi-Presenter Detection	<p>When multiple presenters are detected, the camera will go to your selected Multi-Presenter Detection preset and frame entire group on screen.</p> <ol style="list-style-type: none"> <li>Go to <b>Tracking Settings &gt; Presenter</b>.</li> <li>Make sure <b>Auto Zoom</b> is turned on.</li> <li>Select a preset from the <b>Multi-Presenter Detection</b> drop-down list to turn on Multi-Presenter Detection.</li> </ol> <p><b>Note:</b></p> <ul style="list-style-type: none"> <li>Make sure you have defined the required preset.</li> <li>The preset should cover a wide area where multiple presenters may appear.</li> </ul>

- Turn on **Tracking** and select **Presenter Mode** on the **Tracking Control** panel.

**Note:** Presenter Mode lets you switch the presenter you want to track. Click the **Click Track** button to frame everyone on screen in bounding boxes and click to select the presenter you want to track. Selected presenter will be in a red frame.



### To set up Presenter Mode with the remote control:

1. Use directional buttons to position your camera. Press and hold **Preset**, then press **Number button 1** to save the tracking point (Preset 1).
2. Press **Auto Tracking ON** to turn on Presenter Mode.
3. Press **Upper Body** or **Full body**.
4. To switch presenters, press **Switch**. With each press, cycle through presenters clockwise, starting from the center.

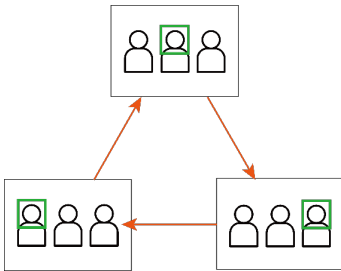

## Zone Mode

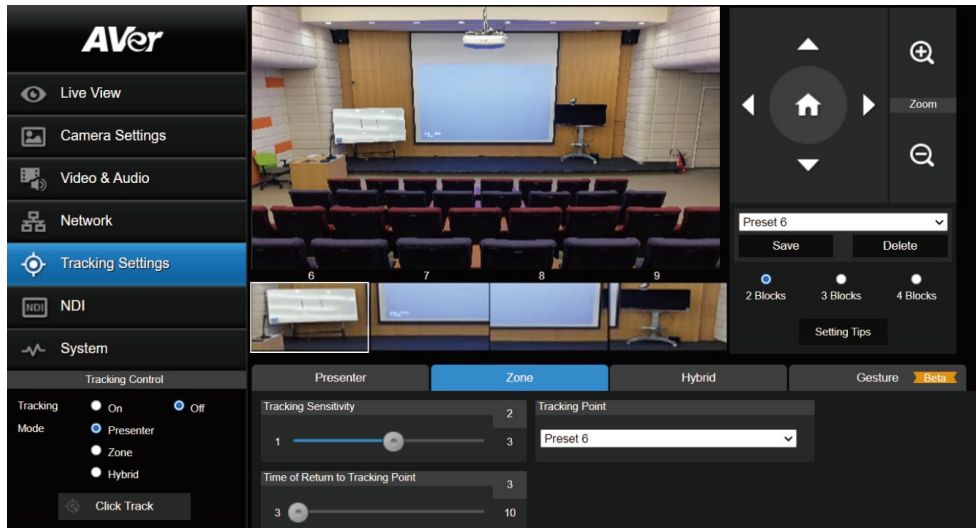

Zone Mode uses up to 4 presets to frame and follow the presenter on screen. When the presenter exits the previous preset, the camera will follow and move to the next preset.

When no one is in the presets, the camera returns to the tracking point (Preset 6 or selected preset).

**Note:** Zone Mode detects any faces or human silhouettes entering the presets. Beside the presenter, make sure there are no other faces or human silhouettes on a poster in the presets to avoid interference.

### To set up Zone Mode:

1. Go to **Tracking Settings > Zone**.
2. Select the number of **Blocks** (presets) you want to track.
3. Select the presets you want to save from the drop-down list. Presets 6–9 are available.

2 Blocks	3 Blocks	4 Blocks
Preset 6, 7	Preset 6, 7, 8	Preset 6, 7, 8, 9

- Use pan, tilt and zoom controls to position your camera and click **Save** to save that position. A thumbnail will appear in the preview. Repeat these steps for all presets.

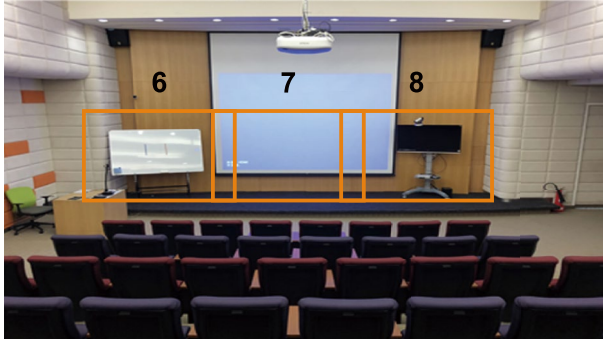

**Note:** Define overlapping presets from left to right for a smooth transition. When the presenter exits the previous preset, the camera will follow and move to the next preset.

- Configure additional settings:

Item	Description
Tracking Sensitivity	Drag the slider to adjust tracking sensitivity.
Time of Return to Tracking Point	Drag the slider to set an idle time (second) before the camera return to the tracking point.
Tracking Point	<p>If no one is in the presets, the camera will return to the tracking point (Preset 6 or selected preset).</p> <div data-bbox="445 906 980 1034" style="background-color: #333; color: #fff; padding: 5px;"> <p>Tracking Point</p> <p>Preset 6 ▾</p> </div>

- Turn on **Tracking** and select **Zone Mode** on the **Tracking Control** panel.



**To set up Zone Mode with the remote control:**

1. Use directional buttons to position your camera. Press and hold **Preset**, then press **Number button 6** to save Preset 6. Repeat these steps for Preset 7.

**Note:** Zone Mode has 2 blocks by default. To select more blocks, access the web interface.

2. Press **Auto Tracking ON** to turn on Presenter Mode
3. Then press and hold **Tracking Point** to switch tracking mode from Presenter Mode to Zone Mode.

## Hybrid Mode

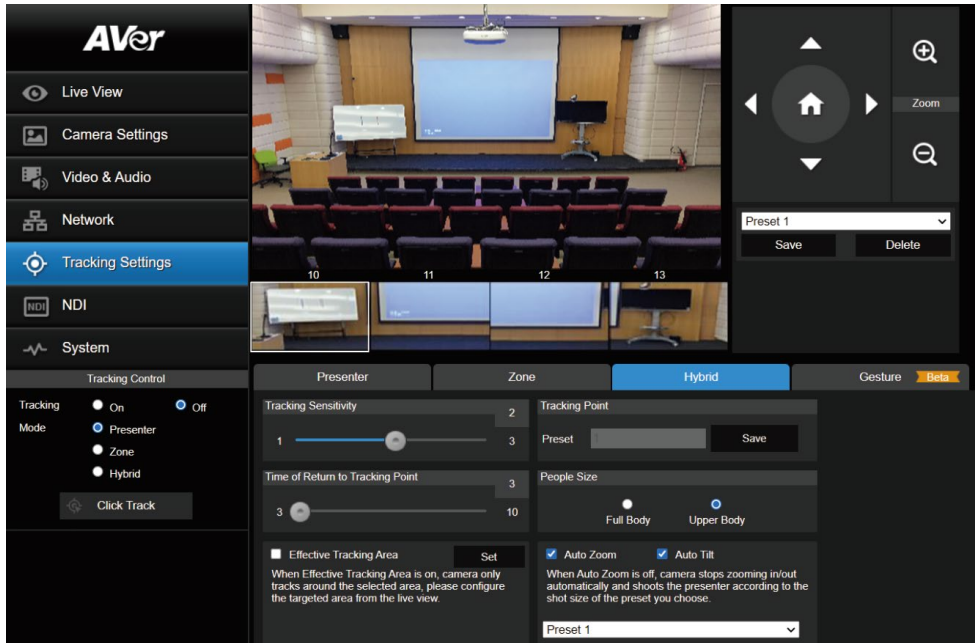

Hybrid Mode combines Presenter Mode and Zone Mode.

Uses presets when the presenter is inside of presets, frames and follows the presenter when they are outside of presets.

When no one is on screen, the camera returns to the tracking point (Preset 1).

### To set up Hybrid Mode:

1. Go to **Tracking Settings > Hybrid**.
2. Use pan, tilt and zoom controls to position your camera and click **Save to Preset 1** to save the **Tracking Point**.
3. Then, select the presets you want to save from the drop-down list. Presets 10–13 are available.

4. Use pan, tilt and zoom controls to position your camera and click **Save** to save that position. A thumbnail will appear in the preview. Repeat these steps for all presets.



**Note:** Do not overlap presets. Leave ample room between presets for a smooth transition.

5. Configure additional settings:

Item	Description
Tracking Sensitivity	Drag the slider to adjust tracking sensitivity.
Time of Return to Tracking Point	Drag the slider to set an idle time (second) before the camera returns to the tracking point.
Effective Tracking Area	Define an effective tracking area. Only presenters inside the area will be tracked. <ol style="list-style-type: none"> <li>Select the checkbox and click <b>Set</b>.</li> <li>Drag the upper-left or the lower-right corner of the red frame to adjust the size of the tracking area.</li> </ol>
Tracking Point	If no one is on screen, the camera will return to the tracking point (Preset 1).
People Size	Frame the presenter's full body or upper body.
Auto Zoom	<ul style="list-style-type: none"> <li>When <b>Auto Zoom</b> is turned off, the zoom ratio will be based on your selected preset from the drop-down list.</li> <li>When <b>Auto Tilt</b> is turned off, the tilt angle will be based on your selected preset from the drop-down list.</li> </ul>
Auto Tilt	<div style="background-color: #333; color: #fff; padding: 10px;"> <input checked="" type="checkbox"/> Auto Zoom      <input checked="" type="checkbox"/> Auto Tilt            When Auto Zoom is off, camera stops zooming in/out automatically and shoots the presenter according to the shot size of the preset you choose.  <div style="border: 1px solid #ccc; padding: 5px; margin-top: 5px;">             Preset 1 <span style="float: right;">▼</span> </div> </div>

6. Turn on **Tracking** and select **Hyrbid Mode** on the **Tracking Control** panel.

**Note:** Presenter Mode lets you switch the presenter you want to track. Click the **Click Track** button to frame everyone on screen in bounding boxes and click to select the presenter you want to track. Selected presenter will be in a red frame.

# Gesture

Control your camera with hand gestures during HDMI output.

The screenshot shows the camera's control interface with the following sections:

- Mode Selection:** Presenter, Zone, Hybrid, and **Gesture Beta** (highlighted).
- Gesture Control Panel:**
  - Tracking+PTZ:** A dropdown menu.
  - When Auto Tracking off:** A note stating "When Auto Tracking off, camera automatically returns to the preset you choose." and a dropdown menu set to "Off".
- Gesture Instructions:**
  - Auto Tracking enable / Switch Presenter:** Raise your hand beside your face (with an open hand) for more than 3 seconds to activate the AutoTracking. Instruct camera to track the person that holds up hand beside his/her face (only enabled when Auto Tracking is on).
  - Auto Tracking disable/Zoom out:** Make a fist beside your face to disable Auto Tracking while it's on, otherwise, perform zoom out.
  - Zoom in:** Position two fingers next to the area you wish to zoom in, and as the camera initiates the zooming process, lower your hand to cease the zoom.
  - Upper/Full body Switch:** Shows four fingers beside your face to switch upper or full body size.
  - Pan/Tilt:** Shows five fingers beside your shoulder and move camera to desired position. Make a fist to stop camera movement.
- Distance Note:** The effective recognized distance of gesture control is 15ft at 1X zoom ratio.

## Note:

- The effective distance is 15 feet at 1X zoom ratio.
- When a gesture is recognized, the LED indicator will flash purple.

## To use gesture control:

1. Select an option from the **Gesture Control** drop-down list:
  - **Off:** Turn off gesture control.
  - **Tracking:** Gesture control is available in tracking modes.
  - **PTZ:** Gesture control is available in PTZ mode.
  - **Tracking + PTZ:** Gesture control is available in all tracking and PTZ modes.
2. You can also select a preset from the bottom drop-down list for the camera to return to when auto tracking is turned off.

# NDI

**Note:** NDI is available for model names with N only.

The screenshot shows the AVer software interface with the NDI settings menu open. The 'NDI' option is selected in the left-hand navigation menu. The settings are as follows:

- Local Device Name:** (Empty text field)
- Device Channel (Camera ID):** AVer\_NDI\_Camera
- Receive Group:** Public
- Reliable UDP:**
- Discovery Server:**
- Discovery Server Address:** 192.168.1.10
- Multicast Server:**
- Multicast Server Mask:** 255.255.255.0
- Multicast Server Address:** 239.255.0.0
- Multicast TTL:** 10

Buttons for 'Confirm' and 'Cancel' are located at the bottom right of the settings panel.

Item	Description
NDI Activate Function	Click to enter your NDI license key. To purchase NDI HX upgrade, please visit NewTek Online Store ( <a href="https://store.newtek.com/ndi-hx-upgrade-for-cameras.html#">https://store.newtek.com/ndi-hx-upgrade-for-cameras.html#</a> )
Local Device Name	Enter a name that identifies your camera group on the NDI software. <ul style="list-style-type: none"> <li>The default is AVer_NDI_Camera.</li> </ul>
Device Channel (Camera ID)	Enter a name that identifies your camera on the NDI software. <ul style="list-style-type: none"> <li>The default is a blank space.</li> <li>A name must have no more than 10 characters. Use number, upper and lower case letter, or special character (! @ % ^ , . / : + ? [ ] { } - _ ~).</li> </ul>
Receive Group	Enter a name for a receive group. <ul style="list-style-type: none"> <li>All devices in the receive group receive the same NDI streams.</li> <li>The receive group should remain <b>public</b>. If this is changed, you will need to join the group through NDI® Access Manager.</li> </ul>

Reliable UDP	Select the checkbox to enable Reliable User Datagram Protocol (RUDP).
Discovery Server	Select the checkbox to enable discovery server to allow devices to discover and connect to each other on a network automatically.
Discovery Server Address	Enter the IP address of a server running a discovery server application.
Multicast Server	Select the checkbox to enable multicast server to allow efficient distribution of NDI streams to multiple receivers without overwhelming the network.
Multicast Server Mask	Enter the network mask to specify the range of IP addresses that are eligible to receive NDI streams.
Multicast Server Address	Enter the IP address of a group of recipients that receive NDI streams from a multicast server.
Multicast TTL	Enter a multicast time to live (TTL) value between 1-255 to control the distance multicast packets can travel.

# System

Item	Description
Upgrade firmware	<p>To upgrade the firmware:</p> <ol style="list-style-type: none"> <li>1. Download the newest firmware from <a href="https://www.aver.com/Downloads/search?q=PTC320UV2">https://www.aver.com/Downloads/search?q=PTC320UV2</a></li> <li>2. On the Web page, go to <b>System &gt; Upgrade firmware</b>.</li> <li>3. Click <b>Choose File</b> to select the firmware.</li> <li>4. Click <b>Upgrade</b> to start upgrading the firmware.</li> <li>5. Refresh the browser after the upgrade process is complete.</li> </ol> <p><b>Note:</b> Keep your camera connected to a power source during firmware upgrade. Network connection will be lost during the process and camera will reboot automatically after upgrading.</p>
Factory Default	Reset the camera to factory default settings.
Login	<p>For first-time login, you'll be prompted to change the username and password:</p> <ul style="list-style-type: none"> <li>• Username: Use 1-32 characters.</li> <li>• Password: Use 8-32 characters and a combination of uppercase letters, lowercase letters, numbers, and symbols</li> </ul>

	(%+ =, - ^/ @. ~). The password cannot be the same as the username.
Language	Change the web interface language.
Reboot	Restart your camera.
Export Log	Export system log.
Power Schedule	Schedule specific times for the camera to reboot or shut down.
Set Date/Time	Set the camera date and time.
Syslog	Turn on to receive technical supports. Enter the <b>IP Address</b> and <b>Port</b> of the receiving device for debug and problem analysis.
Status OSD	Turn on to display preset and zoom ratio on HDMI output.
Setting	Import or export your camera settings
Status Live View	Turn the camera live view on or off.
VISCA Customized Function	Set VISCA customized functions and click <b>OK</b> .
Power Up to Preset	Select a pre-configured preset position from the drop-down list, the camera will move to the preset position when powered up.
Power Off to Preset	Select a pre-configured preset position from the drop-down list, the camera will move to the preset position when powered off.
Power Off Completely	Select a power setting for your camera: <ul style="list-style-type: none"> <li>• <b>On</b>: Shuts down.</li> <li>• <b>Off</b>: Enters Standby mode.</li> </ul>
Sleep to Preset	When no video is transmitted over USB, set up <b>Sleep to Preset</b> and <b>Sleep Timer</b> to move the camera to a defined preset after a period of time for enhanced privacy. <ul style="list-style-type: none"> <li>• To enable: <ol style="list-style-type: none"> <li>1. Make sure the preset has been defined.</li> <li>2. Go to <b>Video &amp; Audio &gt; Theme Mode</b> &gt; choose <b>USB Only</b>.</li> <li>3. Go to <b>Systems &gt; Sleep to Preset</b> &gt; choose a preset.</li> <li>4. Go to <b>Systems &gt; Sleep Timer</b> &gt; select a duration.</li> </ol> </li> <li>• To disable, choose <b>Off</b> from the <b>Sleep to Preset</b> drop-down list or select <b>Off</b> in <b>Sleep Timer</b>.</li> </ul>
Sleep Timer	
Turn on Auto Tracking when using USB Video	Select to turn on auto tracking when streaming over USB. Make sure you have selected <b>USB only</b> in <b>Video Mode</b> .
Help Improving AVer Camera	Opt-in or opt-out of providing anonymous usage data.

# Appendix

## VISCA RS-232 Command Table

Command Set	Command	Command Packet	Comments
CAM_Power	On	8x 01 04 00 02 FF	Power ON/OFF
	Off	8x 01 04 00 03 FF	
CAM_Zoom	Stop	8x 01 04 07 00 FF	
	Tele(Variable)	8x 01 04 07 2p FF	p=0 (Low) to 7 (High)
	Wide(Variable)	8x 01 04 07 3p FF	
	Direct	8x 01 04 47 0p 0q 0r 0s FF	pqrs: Zoom Position PTC310: 0x0000~0x6f20 PTC330: 0x0110~0x5490
CAM_Focus	Stop	8x 01 04 08 00 FF	
	Far (Standard)	8x 01 04 08 02 FF	Each 'Far/Near' needs a 'stop'
	Near (Standard)	8x 01 04 08 03 FF	
	Auto Focus	8x 01 04 38 02 FF	
	Manual Focus	8x 01 04 38 03 FF	
	One Push	8x 01 04 18 01 FF	
	Direct	8x 01 04 47 0p 0q 0r 0s FF	pqrs: Zoom Position
CAM_WB	Auto	8x 01 04 35 00 FF	Normal Auto
	ATW	8x 01 04 35 04 FF	
	Indoor	8x 01 04 35 01 FF	
	Outdoor	8x 01 04 35 02 FF	
	One Push WB	8x 01 04 35 03 FF	One Push WB mode
	Manual	8x 01 04 35 05 FF	Manual Control mode
	One Push	8x 01 04 10 05 FF	One Push WB Trigger
CAM_RGain	Up	8x 01 04 03 02 FF	Manual Control of R Gain
	Down	8x 01 04 03 03 FF	
CAM_Bgain	Up	8x 01 04 04 02 FF	Manual Control of B Gain
	Down	8x 01 04 04 03 FF	
CAM_AE	Full Auto	8x 01 04 39 00 FF	Automatic Exposure mode
	Manual	8x 01 04 39 03 FF	Manual Control mode
	Shutter Priority	8x 01 04 39 0A FF	Shutter Priority Automatic Exposure mode
	Iris Priority	8x 01 04 39 0B FF	Iris Priority Automatic Exposure mode
	Bright	8x 01 04 39 0D FF	Bright Mode (Manual control)
CAM_Shutter	Up	8x 01 04 0A 02 FF	Shutter Setting
	Down	8x 01 04 0A 03 FF	
CAM_Iris	Up	8x 01 04 0B 02 FF	Iris Setting
	Down	8x 01 04 0B 03 FF	
CAM_Gain	Up	8x 01 04 0C 02 FF	Gain Setting
	Down	8x 01 04 0C 03 FF	
CAM_Bright	Up	8x 01 04 0D 02 FF	Bright Setting
	Down	8x 01 04 0D 03 FF	

CAM_Exposure Compensation	Up	8x 01 04 0E 02 FF	Exposure Compensation Amount Setting
	Down	8x 01 04 0E 03 FF	
CAM_Backlight	On	8x 01 04 33 02 FF	Back Light Compensation ON/OFF
	Off	8x 01 04 33 03 FF	
CAM_Preset	Reset	8x 01 04 3F 00 pp FF	pp: Preset Number 0x00~0xFF
	Set	8x 01 04 3F 01 pp FF	
	Recall	8x 01 04 3F 02 pp FF	
CAM_Menu	On/Off	8x 01 06 06 10 FF	Display ON/OFF
Pan-tilt Drive	Up	8x 01 06 01 VV WW 03 01 FF	VV: Pan speed setting 0x01 (low speed) to 0x18 (high speed) WW: Tilt speed setting 0x01 (low speed) to 0x18 (high speed)
	Down	8x 01 06 01 VV WW 03 02 FF	
	Left	8x 01 06 01 VV WW 01 03 FF	
	Right	8x 01 06 01 VV WW 02 03 FF	
	UpLeft	8x 01 06 01 VV WW 01 01 FF	
	UpRight	8x 01 06 01 VV WW 02 01 FF	
	DownLeft	8x 01 06 01 VV WW 01 02 FF	
	DownRight	8x 01 06 01 VV WW 02 02 FF	
	Stop	8x 01 06 01 VV WW 03 03 FF	
	Home	8x 01 06 04 FF	
Reset	8x 01 06 05 FF		
CAM_WDR	On	8x 01 04 3D 02 FF	Wdr ON/OFF
	Off	8x 01 04 3D 03 FF	
CAM_MenuEnter		8x 01 7E 01 02 00 01 FF	Enter Submenu
Tally Lamp ON		8x 01 7E 01 0A 00 02 FF	
Tally Lamp OFF		8x 01 7E 01 0A 00 03 FF	
Freeze	Freeze On	81 01 04 62 02 FF	Freeze On Immediately
	Freeze Off	81 01 04 62 03 FF	Freeze Off Immediately
	Preset Freeze On	81 01 04 62 22 FF	Freeze On When Running Preset
	Preset Freeze Off	81 01 04 62 23 FF	Freeze Off When Running Preset
Auto Tracking	On	8x 01 04 7D 02 FF	Auto tracking ON/OFF
	Off	8x 01 04 7D 03 FF	

CAM_Memory Special	Set	8x 01 04 3F 01 pp FF	These are changeable depending on VISCA Customized Functions web setting: pp: 0x00 To 0xFF normal preset pp: 0x5F => Turn on OSD menu pp: 0xA0 => Full Body pp: 0xA1 => Upper Body pp: 0xA2 => Tracking Point pp: 0xA3 => Switch pp: 0xA4 => Presenter mode (supported in FW v25 or newer) pp: 0xA5 => Zone mode (supported in FW v25 or newer) pp: 0xA6 => Hybrid mode (supported in FW v35 or newer)
Absolute Position	Set	8x 01 06 02 VV WW 0Y 0Y 0Y 0Y 0Z 0Z 0Z 0Z FF	VV: Pan speed setting 0x01 (low speed) to 0x18 (high speed) WW: Tilt speed setting 0x01 (low speed) to 0x18 (high speed) YYYY: Pan Position ZZZZ: Tilt Position
Auto zoom	On	8x 01 04 A0 02 FF	
	Off	8x 01 04 A0 03 FF	
Effective Tracking area	On	8x 01 04 A1 02 FF	
	Off	8x 01 04 A1 03 FF	
RTMP	On	8x 01 04 A2 02 FF	
	Off	8x 01 04 A2 03 FF	
Video mode	IP+Stream	8x 01 04 A3 00 FF	
	USB only	8x 01 04 A3 01 FF	
	NDI only	8x 01 04 A3 02 FF	
	Streaming only	8x 01 04 A3 03 FF	
Reboot	On	8x 01 04 A4 FF	
Preset Affects PTZ & Focus Values Only	On	8x 01 04 A5 02 FF	
	Off	8x 01 04 A5 03 FF	
Relative Zoom Ratio	On	8x 01 04 A6 02 FF	
	Off	8x 01 04 A6 03 FF	
Auto Tilt	On	8x 01 04 A7 02 FF	
	Off	8x 01 04 A7 03 FF	
Auto Zoom/Tilt preset	Set	8x 01 04 A8 pp FF	pp: 0x00 To 0xFF normal preset
Multi presenter	On	8x 01 04 A9 02 FF	
	Off	8x 01 04 A9 03 FF	
Multi presenter preset	Set	8x 01 04 AA pp FF	pp: 0x00 To 0xFF normal preset

Inquiry Command	Command Packet	Reply Packet	Comments
CAM_PowerInq	8x 09 04 00 FF	y0 50 02 FF	On
		y0 50 03 FF	Off
CAM_WBModelInq	8x 09 04 35 FF	y0 50 00 FF	Auto
		y0 50 01 FF	In Door
		y0 50 02 FF	Out Door
		y0 50 03 FF	One Push WB
		y0 50 04 FF	ATW
		y0 50 05 FF	Manual
CAM_RGainInq	8x 09 04 43 FF	y0 50 00 00 0p 0q FF	pq: R Gain
CAM_BGainInq	8x 09 04 44 FF	y0 50 00 00 0p 0q FF	pq: B Gain
CAM_AEModelInq	8x 09 04 39 FF	y0 50 00 FF	Full Auto
		y0 50 03 FF	Manual
		y0 50 0A FF	Shutter Priority
		y0 50 0B FF	Iris Priority
		y0 50 0D FF	Bright
CAM_ShutterPosInq	8x 09 04 4A FF	y0 50 00 00 0p 0q FF	pq: Shutter Position
CAM_IrisPosInq	8x 09 04 4B FF	y0 50 00 00 0p 0q FF	pq: Iris Position
CAM_GainPosInq	8x 09 04 4C FF	y0 50 00 00 0p 0q FF	pq: Gain Position
CAM_BrightPosInq	8x 09 04 4D FF	y0 50 00 00 0p 0q FF	pq: Bright Position
CAM_ExpCompPosInq	8x 09 04 4E FF	y0 50 00 00 0p 0q FF	pq: ExpComp Position
CAM_FocusModelInq	8x 09 04 38 FF	y0 50 02 FF	Auto Focus
		y0 50 03 FF	Manual Focus
CAM_FocusPosInq	8x 09 04 48 FF	y0 50 0p 0q 0r 0s FF	pqrs: Focus Position
zoom_Pos_Inq	8x 09 04 47 FF	y0 50 0p 0q 0r 0s FF	pqrs: Zoom Position
PT_Pos_Inq	8x 09 06 12 FF	y0 50 0Y 0Y 0Y 0Y 0Z 0Z 0Z 0Z FF	YYYY: Pan Position 8A14 to 762C (CENTER 0000) ZZZZ: Tilt Position 468B to E898 (Image Flip: OFF) (CENTER 0000)
CAM_Preset Inq	8x 09 04 3F FF	y0 50 pp FF	Return the last preset number which has been operated pp:01-FF
CAM_Tracking status	8x 09 36 69 02 FF	y0 50 01 FF	On
		y0 50 00 FF	Off
CAM_Tracking_mode	8x 09 36 69 01 FF	y0 50 01 FF	Presenter
		y0 50 02 FF	Zone
		y0 50 03 FF	Hybrid
CAM_Tracking body size	8x 09 36 69 03 FF	y0 50 01 FF	Full body
		y0 50 02 FF	Upper body
CAM_OSD MENU on/off	8x 09 7E 04 76 01 FF	y0 50 02 FF	On
		y0 50 03 FF	Off
CAM_Tally	8x 09 7E 01 0A FF	y0 50 02 FF	On

		y0 50 03 FF	Off
CAM_WDR mode	8x 09 04 3D FF	y0 50 02 FF	On
		y0 50 03 FF	Off
CAM_BLC mode	8x 09 04 33 FF	y0 50 02 FF	On
		y0 50 03 FF	Off
CAM_Live Freeze	8x 09 04 62 01 FF	y0 50 02 FF	Freeze On
		y0 50 03 FF	Freeze Off
CAM_Preset Freeze	8x 09 04 62 02 FF	y0 50 02 FF	Preset Freeze On
		y0 50 03 FF	Preset Freeze Off
Firmware version	8x 09 36 69 04 FF	y0 50 0p 0q 0r 0s 0t 0u 0v 0w FF	fw_ver: p.q.rstu.vw
USB Status	8x 09 36 69 05 FF	y0 50 00 FF	USB cable plug out
		y0 50 01 FF	USB cable plug in
UVC Status	8x 09 36 69 06 FF	y0 50 00 FF	UVC stream off
		y0 50 01 FF	UVC stream on

# Visca over IP Settings

## VISCA over IP

### PORT

Internet protocol	IPv4
Transport protocol	UDP
Port address	52381

### FORMAT

	byte 0	byte 1	byte 2	byte 3	byte 4	byte 5	byte 6	byte 7	byte8 ~ byte23	
func	Payload type		Payload length		Sequence number			Payload (1 to 16 bytes)		
data	Value1	Value2	3~16 (0x001~0x010)		0X00000000 ~ 0XFFFFFFF			VISCA Packet (see page VISCA)		

### Payload type

Name	Value1	Value2	Description
VISCA command	0x01	0x00	Stores the VISCA command.
VISCA inquiry	0x01	0x10	Stores the VISCA inquiry.
VISCA reply	0x01	0x11	Stores the reply for the VISCA command or VISCA inquiry

### Sequence number

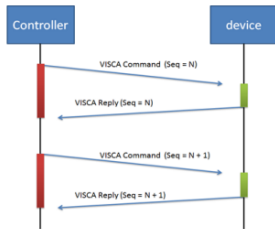

Sequence number = N

# CGI Command

CGI List for Video Transmission					
CGI Item name	URL	Command	Parameter Name	Parameter value	Description
Get JPEG	<u>/snapshot</u>				1280x720 jpg
Get RTSP stream	rtsp://ip/live_st1				

CGI List for Camera Control					
CGI item name	URL	Command	Parameter Name	Parameter value	Description
up start	/cgi-bin?SetPtzf=	1,0,1&(random)			
up end	/cgi-bin?SetPtzf=	1,0,2&(random)			
down start	/cgi-bin?SetPtzf=	1,1,1&(random)			
down end	/cgi-bin?SetPtzf=	1,1,2&(random)			
left start	/cgi-bin?SetPtzf=	0,1,1&(random)			
left end	/cgi-bin?SetPtzf=	0,1,2&(random)			
right start	/cgi-bin?SetPtzf=	0,0,1&(random)			
right end	/cgi-bin?SetPtzf=	0,0,2&(random)			
zoom_in start	/cgi-bin?SetPtzf=	2,0,1&(random)			
zoom_in end	/cgi-bin?SetPtzf=	2,0,2&(random)			
zoom_out start	/cgi-bin?SetPtzf=	2,1,1&(random)			
zoom_out end	/cgi-bin?SetPtzf=	2,1,2&(random)			
set preset:	/cgi-bin?ActPreset=	1,N&(random)			N : position
load preset:	/cgi-bin?ActPreset=	0,N&(random)			N : position
set preset speed	/cgi-bin?Set=preset_speed,3,val	val: {min: 1, max: 6}			
Absolute Position (Pan)	/cgi-bin?Set=ptz_p,3,val	val: {min: 2048, mid: 962944, max: 1925888}			Follows CGI preset speed

Absolute Position (Tilt)	/cgi-bin?Set=ptz_t,3,val	val: {min: 2048, mid: 165696, max: 662784}			Follows CGI preset speed
Absolute Position (Zoom)	/cgi-bin?Set=ptz_z,3,val	val: {min: 2048, mid: 14224, max: 28448}			Follows CGI preset speed

### CGI List for Various Settings

CGI item name	URL	Command	Parameter Name	Parameter value	Description
exposure value	/cgi-bin?Set=	img_expo_expo,3,N&(random)	value	1 ~ 9	N : value
saturation	/cgi-bin?Set=	img_saturation,3,N&(random)	value	0 ~ 10	N : value
contrast	/cgi-bin?Set=	img_contrast,3,N&(random)	value	0 ~ 4	N : value
Tracking on:	/cgi-bin?Set=	trk_tracking_on,3,1			
Tracking off:	/cgi-bin?Set=	trk_tracking_on,3,0			
Reboot	GET(Basic Authentication)	/cgi-bin?OnePush=!			
Factory Reset	GET(Basic Authentication)	/cgi-bin?OnePush=d			
Mode Presenter		/cgi-bin?Set=trk_mode,3,1&X	value	random number	X : value
Mode Zone		/cgi-bin?Set=trk_mode,3,2&X	value	random number	X : value
Mode Hybrid		/cgi-bin?Set=trk_mode,3,3&X			
Mode Get	GET(Basic Authentication)	/cgi-bin?Get=trk_mode,3&_X	- Reply	Presenter trk_mode,3=1 Zone trk_mode,3=2 Hybrid trk_mode,3=3	X : value
Click Track ON	GET(Basic Authentication)	/cgi-bin?Set=trk_up_date_detect,3,1			
Click Track OFF	GET(Basic Authentication)	/cgi-bin?Set=trk_up			

		date_detect,3,0			
Click Track Get detect zone (Humanoid outlines) number	GET(Basic Authentication)	/cgi-bin?Get=trk_detect_num,3			Need to be sent along with Click Track ON command
	- Reply	"trk_detect_num,3=X\r\n"	X: The amount of humanoid outlines, maximum: 50		
Click Track Get detect zone (Humanoid outlines) info	GET(Basic Authentication)	/cgi-bin?GetTrackingDetectZone=X	X: The amount of humanoid outlines, maximum: 50		
	- Reply	"focus:-1\nzone[00]:00,119,720,960\nzone[01]:-1502615204,-1366225632,01,-1366223544"	focus - The number of humanoid outline being tracked. zone[NN]:x,y,w,h - based on 1080P resolution	The upper left corner of the screen is the coordinate reference (0,0), x-coordinate/y-coordinate/w width/h height, based on the upper left corner of the humanoid outline. The number following indicates the number of the tracked person, for example, -1 means that no one is being tracked. If one of the three is being tracked, one of 0, 1 and 2 will appear after the 'focus'.	
Click Track Set target zone	GET(Basic Authentication)	/cgi-bin?Set=trk_as_sign_zone,3,X	X: The number of the human outlines		
	- Reply	http response: ok			
	GET(Basic Authentication)	/cgi-bin?SetString=TrackingFocusZone,[x,y,w,h]			
	- Reply	http response: ok			

Tracking On/Off Get	GET(Basic Authentication)	/cgi-bin?Get=trk_tracking_on,3&_=X	- Reply	On trk_tracking_on,3=1 Off trk_tracking_on,3=0"	X : value
RTMP Start streamming	/cgi-bin?Set=	vdo_rtmp_enable,3,1			
RTMP Stop streamming	/cgi-bin?Set=	vdo_rtmp_enable,3,0			
USB status	GET(Basic Authentication)	/cgi-bin?Get=usb_status_inquire,3			
	- Reply	"usb_status_inquire,3=X\r\n"	X: 0(plug out), 1(plug in)		
UVC status	GET(Basic Authentication)	/cgi-bin?Get=uvc_status_inquire,3			
	- Reply	"uvc_status_inquire,3=X\r\n"	X: 0(stream off), 1(stream on)		
Status get (Modle name & mac & FW_VER)		/cgi-bin?GetString=sys_name&net_mac&sys_fw_version&_ =1635216271678		<a href="http://10.100.105.110/cgi-bin?GetString=sys_name&amp;net_mac&amp;sys_fw_version&amp;_ =1635216271678">http://10.100.105.110/cgi-bin?GetString=sys_name&amp;net_mac&amp;sys_fw_version&amp;_ =1635216271678</a>	
Serial No. get		/cgi-bin?GetSerialNumber&_ =1635216271680		<a href="http://10.100.105.110/cgi-bin?GetSerialNumber&amp;_ =1635216271680">http://10.100.105.110/cgi-bin?GetSerialNumber&amp;_ =1635216271680</a>	
script (Using cURL to update firmware)	curl.exe -X POST --user NAME:PASSWORD -F file1=@./ISP_FILE "http://IP_ADDRESS/system/"			Please download curl (curl for Windows), this is a command line tool for network transferring. Put curl.exe and ISP file in the same folder. and then execute the script to upgrade camera.  For example, ISP file is 0.0000.29.dat , IP address is 10.100.105.109 and	

				<p>username:password is 1:1 , you can enter this script to execute ISP process.</p> <pre>curl.exe -X POST --user 1:1 -F file1=@./0.0.000 0.29.dat "http://10.100.10 5.109/system/"</pre>	
--	--	--	--	--	--

# Pelco P Command

PTC300V2 Pelco-P command

PAN AND TILT COMMANDS		P/T bit(byte4.0) = 0						
func	byte 1	byte 2	byte 3	byte 4	byte 5	byte 6	byte 7	byte 8
	STX	ADDR	data1	data2	data3	data4	ETX	checksum
data	0xA0	0~7F	cmd 1	cmd 2	Pan speed	Tilt speed	0xAF	1~7 XOR

note : speed = 0x00~0x30

byte3 : command 1

bit 7	bit 6	bit 5	bit 4	bit 3	bit 2	bit 1	bit 0
NA	CAM ON	NA	CAM ON/OFF	NA	NA	NA	NA

note : power off : byte3.6 = 0 & byte3.4 = 1

byte4: command 2

bit 7	bit 6	bit 5	bit 4	bit 3	bit 2	bit 1	bit 0
NA	ZOOM Wide	ZOOM Tele	TILT Down	TILT Up	PAN Left	PAN Right	P/T bit 0 (always)

EXTENDED COMMAND SET

P/T bit(byte4.0) = 1

func	byte 1	byte 2	byte 3	byte 4	byte 5	byte 6	byte 7	byte 8
Set Preset XX	0xA0	0~7	0x00	0x03	0x00	Preset #	0xAF	1~7 XOR
Go To Preset XX	0xA0	0~7	0x00	0x07	0x00	Preset #	0xAF	1~7 XOR
Track ON	0xA0	0~7	0x00	0x65	0x00	0x00	0xAF	1~7 XOR
Track OFF	0xA0	0~7	0x00	0x67	0x00	0x00	0xAF	1~7 XOR

note : Preset # : 0x01 ~ 0xFF  
Profile # : 0x01 ~ 0x05

# Pelco D Command

pelco d command

PAN AND TILT COMMANDS		P/T bit(byte4.0) = 0					
	byte 1	byte 2	byte 3	byte 4	byte 5	byte 6	byte 7
func	SYNC	ADDR	cmd 1	cmd 2	data1	data2	checksum
data	0xFF	1~80	cmd 1	cmd 2	Pan speed	Tilt speed	2*6 SUM

note : speed = 0x00~0x30

byte3 : command 1								
	bit 7	bit 6	bit 5	bit 4	bit 3	bit 2	bit 1	bit 0
SENSE	ON	NA	NA	NA	CAM ON/OFF	NA	NA	NA

note : power off : byte3.7 = 0 & byte3.3 = 1

byte4 : command 2								
	bit 7	bit 6	bit 5	bit 4	bit 3	bit 2	bit 1	bit 0
	NA	ZOOM Wide	ZOOM Tele	TILT Down	TILT Up	PAN Left	PAN Right	P/T bit 0(always)

EXTENDED COMMAND SET		P/T bit(byte4.0) = 1					
	byte 1	byte 2	byte 3	byte 4	byte 5	byte 6	byte 7
func	SYNC	ADDR	data1	data2	data3	data4	checksum
Set Preset XX	0xFF	1~8	0x00	0x03	0x00	Preset #	2*6 SUM
Go To Preset XX	0xFF	1~8	0x00	0x07	0x00	Preset #	2*6 SUM
Track ON	0xFF	1~8	0x00	0x65	0x00	0x00	2*6 SUM
Track OFF	0xFF	1~8	0x00	0x67	0x00	0x00	2*6 SUM

note : Preset # : 0x01 ~ 0xFF

Example:

Camera Address: 1

Pan Left at high speed: FF 01 00 04 3F 00 44

Pan Right at medium speed: FF 01 00 02 20 00 23

Tilt Up at high speed: FF 01 00 08 00 3F 48

Tilt Down at medium speed: FF 01 00 10 20 00 31

Stop all actions (Pan / Tilt / Zoom / Iris etc.): FF 01 00 00 00 00 01