

VB342 Pro

4K PTZ Video Bar (Conference Camera)

— User Manual —

Warning

- Hold the bottom of the camera with both hands to carry the camera.
Whether the camera is connected to power or not, do not grab any part of the lens or the lens holder to carry the camera or adjust pan and tilt.
- Do not drop the camera or subject it to physical shock.
- Ensure the power supply voltage is correct before using the camera.
- Do not place the camera where the cord can be stepped on as this may result in fraying or damage to the lead or the plug.
- To reduce the risk of fire or electric shock, do not expose the camera to rain or moisture.
Warranty will be voided if any unauthorized modifications are done to the camera.

Federal Communications Commission Statement

NOTE: This equipment has been tested and found to comply with the limits for a Class A digital device, pursuant to part 15 of the FCC Rules. These limits are designed to provide reasonable protection against harmful interference when the equipment is operated in a commercial environment. This equipment generates, uses, and can radiate radiofrequency energy and, if not installed and used in accordance with the instruction manual, may cause harmful interference to radio communications.

Operation of this equipment in a residential area is likely to cause harmful interference in which case the user will be required to correct the interference at his own expense.

FCC Caution: Any changes or modifications not expressly approved by the party responsible for compliance could void the user's authority to operate this equipment.

This device complies with part 15 of the FCC Rules.

Operation is subject to the following two conditions:

- (1) This device may not cause harmful interference, and
- (2) this device must accept any interference received, including interference that may cause undesired operation.

This Class A digital apparatus complies with Canadian ICES-003. Cet appareil numérique de la classe A est conforme à la norme NMB-003 du Canada.

Warning

This is a class A product. In a domestic environment this product may cause radio interference in which case the user may be required to take adequate measures.

Caution

Risk of explosion if battery is replaced by an incorrect type. Dispose of used batteries according to the instructions.

PSTI Statement of Compliance

Please refer to the following website: <https://www.aver.com/product-security-advisory>

VCCI-A

この装置は、クラス A 機器です。この装置を住宅環境で使用すると電波妨害を引き起こすことがあります。この場合には使用者が適切な対策を講ずるよう要求されることがあります。

(注)本製品同梱の電源ケーブルは、本製品同梱の電源アダプタでのみ使用してください。
本製品同梱の電源ケーブルは、他の電気機器では使用できません。

사 용 자 안 내 문

이 기기는 업무용 환경에서 사용할 목적으로 적합성평가를 받은 기기로서 가정용 환경에서 사용하는 경우 전자파간섭의 우려가 있습니다.

※ 사용자 안내문은 "업무용 방송통신기자재"에만 적용됩니다.

기종별

사용자안내문

A 급 기기
(업무용 방송통신기자재)

이 기기는 업무용(A 급) 전자파적합기기로서 판매자 또는 사용자는 이 점을 주의하시기 바라며, 가정외의 지역에서 사용하는 것을 목적으로 합니다.

DISCLAIMER

No warranty or representation, either expressed or implied, is made with respect to the contents of this documentation, its quality, performance, merchantability, or fitness for a particular purpose. Information presented in this documentation has been carefully checked for reliability; however, no responsibility is assumed for inaccuracies. The information contained in this documentation is subject to change without notice.

In no event will AVer Information Inc. be liable for direct, indirect, special, incidental, or consequential damages arising out of the use or inability to use this product or documentation, even if advised of the possibility of such damages.

TRADEMARKS

"AVer" is a trademark owned by AVer Information Inc. Other trademarks used herein for description purpose only belong to each of their companies.

COPYRIGHT

©2025 AVer Information Inc. All rights reserved. | December 16, 2025

All rights of this object belong to AVer Information Inc. Reproduced or transmitted in any form or by any means without the prior written permission of AVer Information Inc. is prohibited. All information or specifications are subject to change without prior notice.

More Help

For FAQs, technical support, software and user manual download, please visit:

Non-USA

Download Center: <https://www.aver.com/download-center>

Technical Support: <https://www.aver.com/technical-support>

USA

Download Center: <https://www.averusa.com/business/support>

Technical Support: <https://averusa.force.com/support/s/contactsupport>

Contact Information

Headquarters

AVer Information Inc.
8F, No.157, Da-An Rd.,
Tucheng Dist., New Taipei City
236042, Taiwan
Tel: +886 (2) 2269 8535

USA Branch Office

AVer Information Inc., Americas
44061 Nobel Drive, Fremont, CA
94538, USA
Tel: +1 (408) 263 3828
Toll-free: +1 (877) 528 7824

Europe Branch Office

AVer Information Europe B.V.
Westblaak 134, 3012 KM,
Rotterdam, The Netherlands
Tel: +31 (0) 10 7600 550

Japan Branch Office

アバー・インフォメーション株式会社
〒160-0023 日本東京都新宿区
西新宿 3-2-26 立花新宿ビル 7
階
Tel: +81 (0) 3 5989 0290
お客様サポートセンター(固定電
話のみ): +81 (0) 120 008 382

Vietnam Branch Office

Công ty TNHH AVer Information
(Việt Nam)
Tầng 5, 596 Nguyễn Đình Chiểu,
P.3, Quận 3, Thành phố Hồ Chí
Minh 700000, Việt Nam
Tel: +84 (0) 28 22 539 211
Hỗ trợ kỹ thuật: +84 (0) 90 70 080
77

Korea Office

한국 에버 인포메이션 (주)
서울시 종로구 새문안로 92
(신문로 1가,
광화문오피시아빌딩) 1831,
1832 호
Tel: +82 (0) 2 722 8535

Contents

Warning	2
Overview	1
Package Contents.....	1
Optional Accessories.....	2
Parts Info.....	3
LED Indicator.....	4
Remote Control.....	5
Combination Buttons.....	6
Connection	7
Device Connection.....	7
USB 2.0 and USB 3.1 Resolution and Frame Rate.....	7
Bluetooth Dongle Connection.....	8
Ethernet Connection.....	9
Expansion Speakerphone Connection (Optional).....	9
Expansion Microphone Connection (Optional).....	10
RS-232 Connection.....	11
RS-232 Port Pin Definition.....	11
Mini Din 6 to D-Sub 9 Cable Pin Definition.....	11
Connect VB342 Pro to a Camera Controller or Computer.....	12
Installation	13
Wall Mount Installation.....	13
TV VESA Mount Installation (Optional).....	14
Get Started	17
Make a Video Call.....	17
Access the Web Interface.....	17
AVer IP Finder.....	17
Room Management.....	19

Log In for the First Time	20
Web Interface.....	21
PTZ Control.....	21
Overview of PTZ Control.....	21
Save, Load and Clear a Preset	22
Add and Delete Available Presets (Presets 10-127).....	22
Setting.....	23
Overview of the Floating Live View	26
Tracking Mode	27
Gesture Control.....	29
Video Format	31
Network	32
System	33
Audio.....	35
Room Management.....	36
Configure Settings on Room Management	36
EZLive.....	37

Overview

Package Contents



VB342 Pro

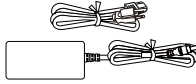

Power Adapter &
Power Cord



Remote Control

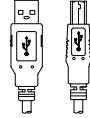

USB 2.0 Type-B to
Type-A Cable (5 m)



USB Type-A to
Type-C Adapter

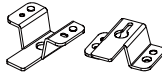

Wall Mount
Bracket (x2)



M5 x 8 mm
Wall Mount Screw (x4)



1/4"-20 L=7.5 mm
Tripod Screw (x3)



Drill Template

Optional Accessories

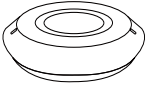

Expansion Speakerphone
10m/ 20m w/ Cable



Expansion Microphone
10m/ 20m w/ Cable

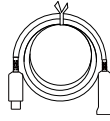

USB 3.1 Extender 10
m/20 m/30 m

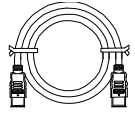

HDMI Cable



USB 3.0 Type-B to Type-A
Cable (3 m)

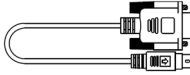

Mini Din 6 to RS-232
Adapter Cable



Audio-out Converter



TV VESA Mount



Bluetooth Dongle

* Optional accessories may vary based on the country or region where sold.

Parts Info

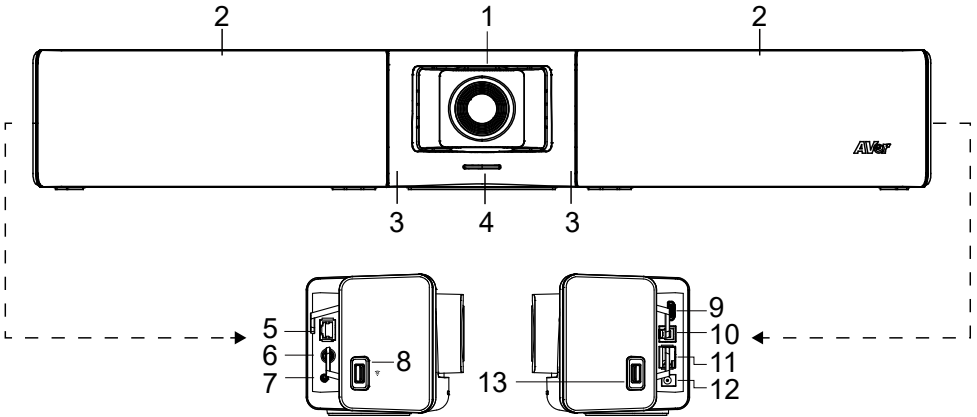

- | | |
|---|---|
| 1. Lens | 7. Phone In (Default) / Audio Out Port* |
| 2. Microphone Array (10 Built-in Microphones) | 8. USB 2.0 Type A Port (for Bluetooth Dongle) |
| 3. IR Sensor | 9. HDMI Output Port (to TV)*** |
| 4. LED Indicator | 10. USB 3.0 Type B Port (for Computer) |
| 5. Expansion Audio Port | 11. RJ-45 Ethernet Port |
| 6. RS-232 Port | 12. DC Power Jack |
| | 13. USB 2.0 Port**** |

*To use the audio out function for HA system, set up with Room Management software and purchase audio-out converter (TRS female to TRRS male) from AVer.

**The HDMI output port supports USB display.

***Do not use a USB extender cable when connecting your Mac computer to the VB342 Pro via the USB 2.0 port. Your Mac computer may not detect the VB342 Pro.

LED Indicator

Color	Status
Solid red	Start-up
Solid orange	Standby
Solid white	Normal
Solid blue	Streaming over USB on Room Management
Solid red	Microphone muted
Solid white	Call on hold
Solid purple	Active call
Blinking white or blue (based on previous status)	Incoming call
Blinking white, blue or purple (based on previous status)	Call waiting
Blinking blue for 2 seconds	Gesture control is activated
Blinking blue for 4 seconds	Performing a gesture command

Remote Control



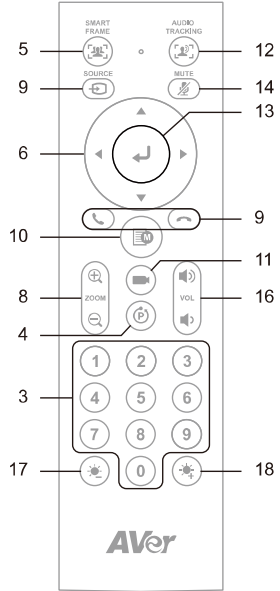
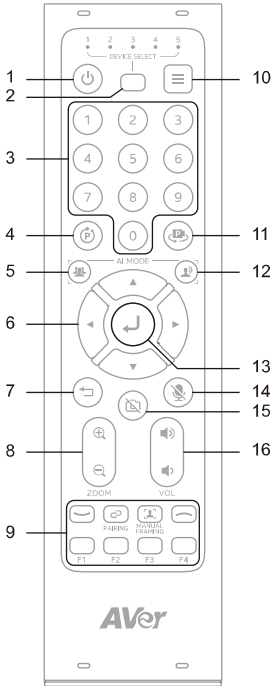

Your device may come with one of the following remote controls.



Name	Function
1. Power	N/A
2. Camera Select	Select 1 to operate the camera. The remote control has been set to 1 at the factory. With each press, cycle through 1-5
3. Number Buttons	<ul style="list-style-type: none"> To save a preset: Press and hold a Number (0-9). To load a preset: Press a Number (0-9).
4. Combination Button	Open combination buttons guide. Refer to < Combination Buttons > for details.
5. SmartFrame	Press to frame entire group on screen. Press and hold to cycle through tracking modes. <ul style="list-style-type: none"> To hide the SmartFrame icon , go to Setting > On-Screen Menu > Off on the web interface or in Room Management.
6. Pan-Tilt Control	Pan and tilt direction control.

7. Back	N/A
8. Zoom In/Out	Zoom in or out.
9. Function Buttons	<ul style="list-style-type: none"> • Call/Answer: Start or answer a call. • Pairing: Turn Bluetooth on or off. • Manual Framing: N/A • Hang Up: End call. • F2: Press and hold to switch between DHCP and Static IP. • F1, F3 and F4: N/A
10. Menu	Open the gesture control guide.
11. Load Preset	With each press, cycle through defined presets.
12. Audio Tracking	Press and hold to cycle through audio tracking modes.
13. Enter	Press to display current AI function on closed caption and autofocus once.
14. Mute	Mute or unmute microphone.
15. Camera Off	N/A
16. Volume	Volume up or down.
17. Brightness -	Decrease image brightness.
18. Brightness +	Increase image brightness.

Combination Buttons

Press consecutively	To
 + 1	Turn wide dynamic range (WDR) on or off.
 + 2	Turn Save Preset on or off.
 + 3	Turn RTMP streaming on or off.
 + 4	Enter sleep mode when not streaming over USB.

Connection

Device Connection

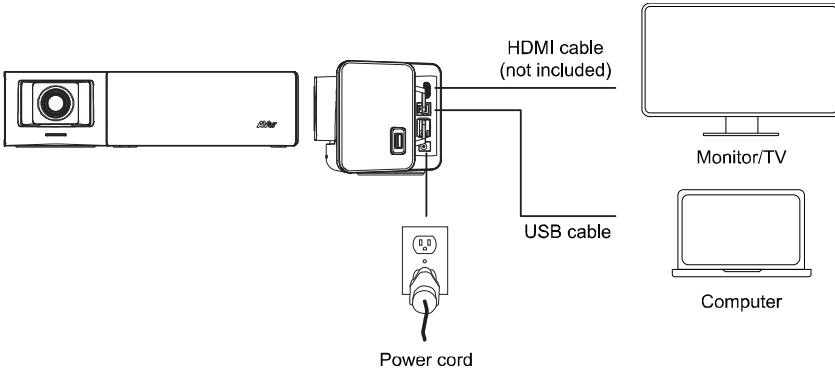

1. Connect your VB342 Pro to a computer using the included USB 2.0 cable, and to a power outlet using the included power cord. Use the cable management slot to secure and manage cables.
2. Connect your VB342 Pro to a TV or monitor using an HDMI cable.

Note: Windows® 7 OS users may require a USB display driver. You can install the USB display driver with Room Management software: Click **Setting** on your camera card > **System** > **Install Driver of USB Display** > **Start**.

USB 2.0 and USB 3.1 Resolution and Frame Rate

USB 2.0		USB 3.1	
YUV	M-JPEG	YUV	M-JPEG
- 640x480 or less resolution, up to 30fps - 720p, up to 10fps	- Up to 4k/30fps - 1080p/60fps	- Up to 1080p/30fps - 720p/60fps	- Up to 4k/30fps - 1080p/60fps

Bluetooth Dongle Connection

Use VB342 Pro as a mobile phone's external audio device.

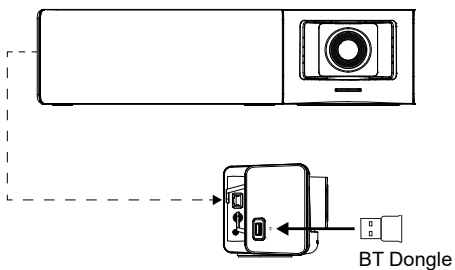

1. Plug the Bluetooth dongle into the USB 2.0 Type-A port before connecting to power.
2. Press the **Pair** button  on the remote control or turn on Bluetooth in Room Management.
3. Open the Bluetooth setting on your phone and select VB342 Pro to connect.

Ethernet Connection

Connect to Ethernet and access your camera's web interface.

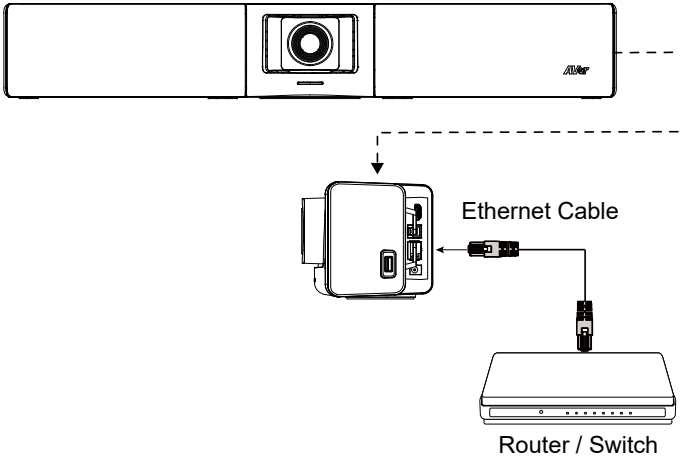

Expansion Speakerphone Connection (Optional)

Connect the expansion audio port (red) on your camera to the expansion port (yellow) on the expansion speakerphone using the included RJ-45 cable.

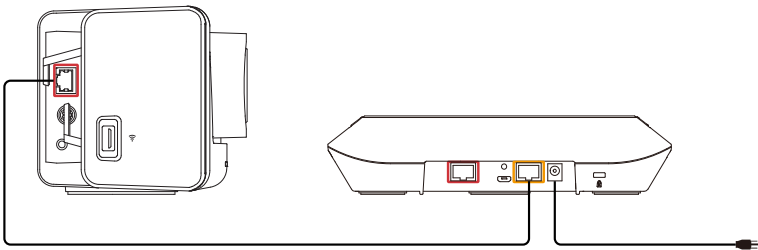

- The expansion speakerphone comes with a 10 m or 20 m cable.
- When the expansion speakerphone is connected to a video bar, the expansion speakerphone can't be daisy-chained to other expansion speakerphones.

Expansion Microphone Connection (Optional)

Connect the expansion audio port (red) on your camera to the mic out port (yellow) on the expansion microphone using the included RJ-45 cable.

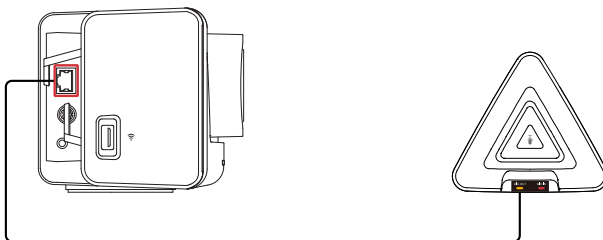

- The expansion microphone comes with a 10 m or 20 m cable.
- When the expansion microphone is connected to a video bar, the expansion microphone can't be daisy-chained to other expansion microphones.

RS-232 Connection

RS-232 Port Pin Definition

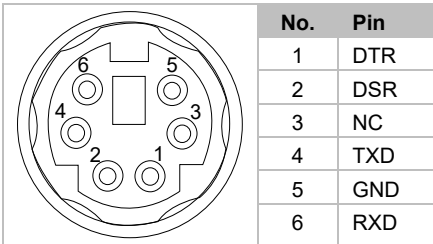

Mini Din 6 to D-Sub 9 Cable Pin Definition

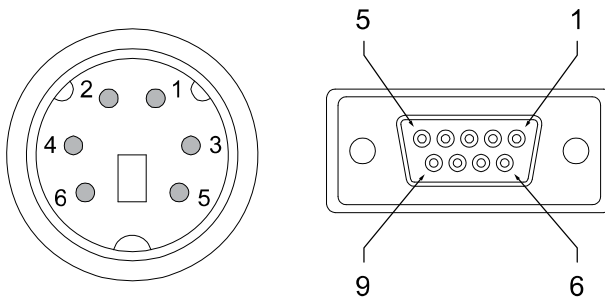

Connect VB342 Pro to a Camera Controller or Computer

- Connection using AVer mini din 6 to RS-232 adapter cable

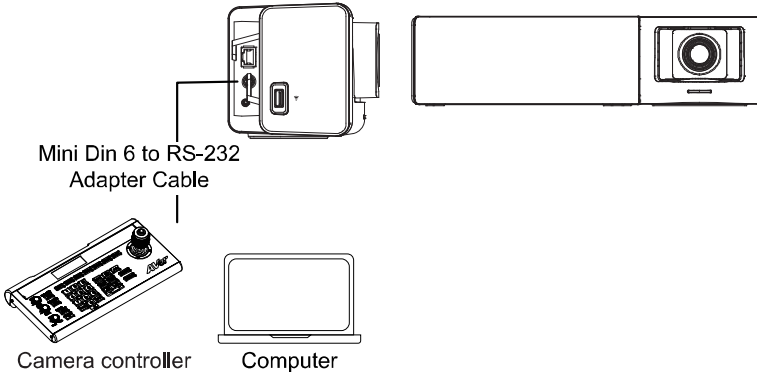

- Pin connection without using AVer Mini Din 6 to RS-232 adapter cable

Mini DIN6		DB9
Camera		Camera controller, PC
1. DTR	→	6. DSR
2. DSR	→	4. DTR
4. TXD	→	2. RXD
6. RXD	→	3. TXD
		1. DCD
		5. GND
		7. RTS
		8. CTX
		9. RI

Installation

Wall Mount Installation

1. Level and tape the drill template to the wall. Drill pilot holes through the template and into the wall.

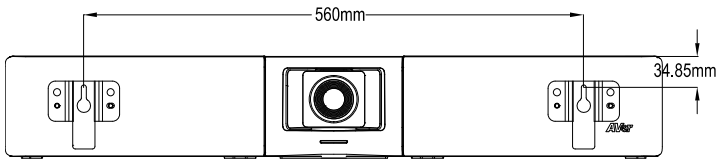

2. Remove the template and Insert anchors.
Cement wall: M4 x 20 mm self-tapping screws (x2) + plastic conical anchors
Wooden wall: M4 x 20 mm self-tapping screws (x2)
3. Insert the included wall mount screws through the wall mount brackets and tighten to the rear panel of the camera.

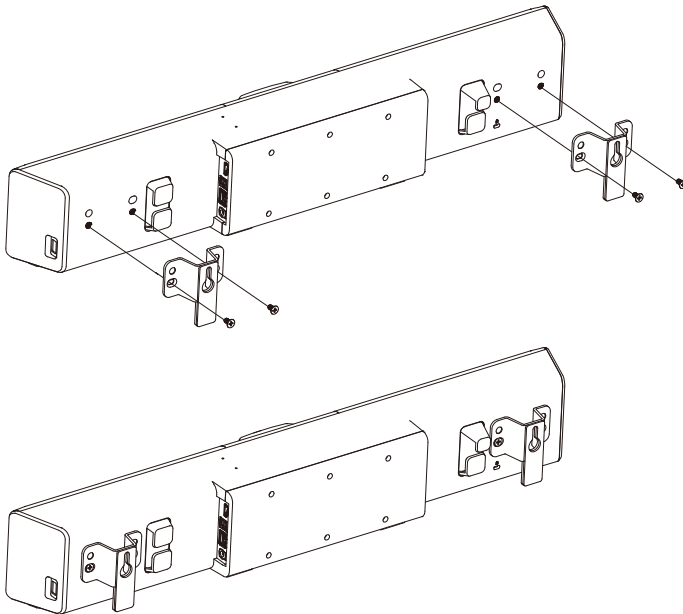









4. Align the wall mount brackets to the screws on the wall and hang the camera.

TV VESA Mount Installation (Optional)

Package Contents:



- | | |
|---|---|
|  Screw(M5*10) x 2 |  Silicone washer x 2 |
|  Screw(M6*15) x 4 |  Metal washer x 2 |
|  Screw(M6*20) x 4 |  Washer(M6) x 4 |
|  Screw(M8*20) x 4 |  Washer(M8) x 4 |
|  Screw(M8*30) x 4 | |

1. Fix the screw (M5*10) with silicone washer in suitable holes (1~5).

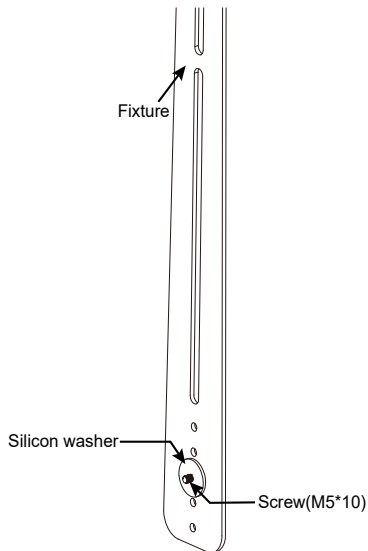

2. Secure the fixture on the rear side panel of the camera. Don't screw tight at this stage. You can select among the two screw holes for screwing the fixtures.

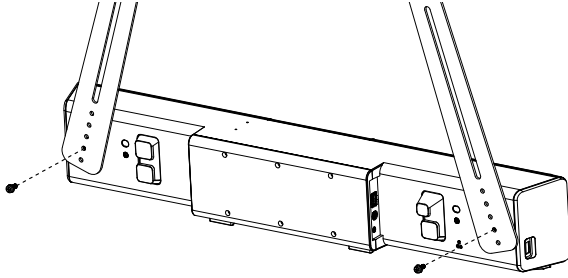

3. Place the metal washers on the mount holes of TV.
[Note] If users do not need to install the mount rack of TV, just skip step 3 to 5 and go to step 6.

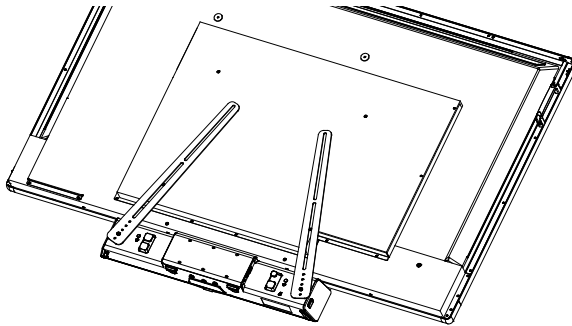

4. Place mount rack of TV on top of fixture.

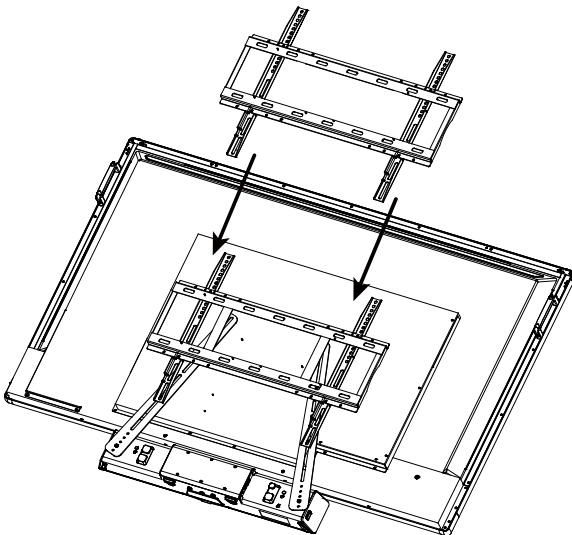

5. Secure the mount rack and fixture on the TV. Please do not screw tight at this stage. Then, adjust the mount rack and fixture to an appropriate position if needed. Finally, tightly screw all screws.

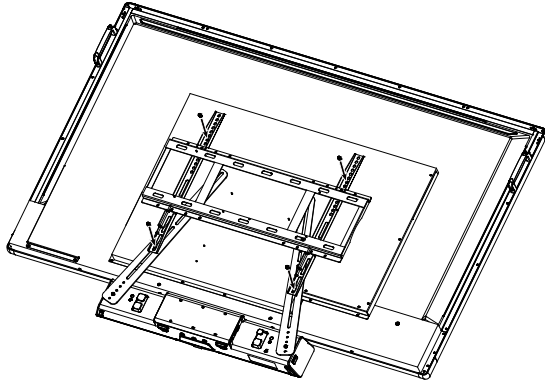

6. If users don't need to install mount rack of TV, then, secure the fixture on the TV. Then, adjust the fixture to an appropriate position if needed. Finally, tightly screw all screws.

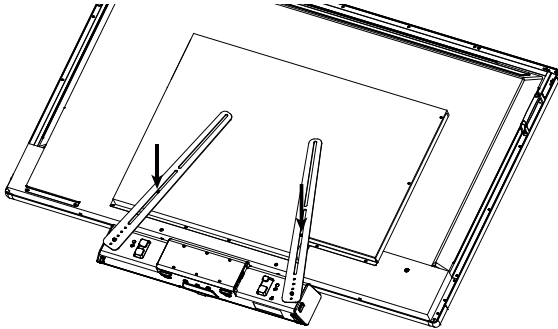

7. The camera can be mounted on top or bottom of the TV. Both ways of installation are the same and please follow the steps described above.

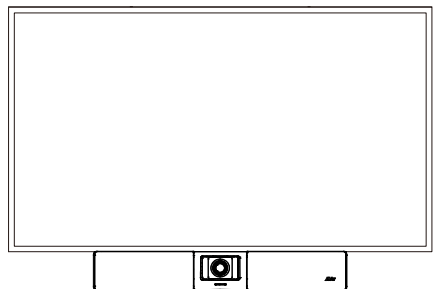
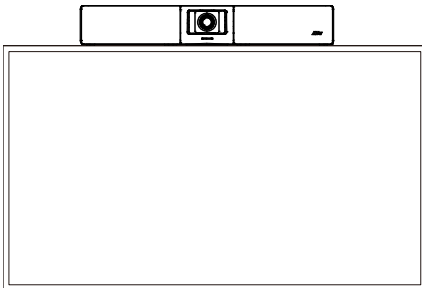

Get Started

Make a Video Call

The VB342 Pro is a plug-n-play device. Open your video conferencing software and select the VB342 Pro for **Video** and **Audio**.

Access the Web Interface

To access the web interface of your device, you can use any of the following software to find its IP address:

- AVer IP Finder
- Room Management

Note:

- The device's default network is DHCP.
- The device's default password is **aver4321**.

AVer IP Finder

The screenshot shows the AVer IP Finder application window. It has a title bar with the text "AVer IP finder for USB-CAM v1.0.1002.3". The main interface is divided into several sections:

- Network Device:** A dropdown menu showing "Realtek PCIe GbE Family Controller" and a "Search" button.
- Login:** A dialog box with a "Password" field.
- Network Setting:** A section containing a "Search Result" table and "Settings" for network configuration.

The "Search Result" table is as follows:

No.	Status	Progress	Model Name	Device Name	FW version	IPv4 Address	MAC Address	IPv6 Address
<input type="checkbox"/> 1	Working		CAM550	CAM550	0.0.8004.71	10.100.90.75:80	00:18:1a:60:4...	[]:80
<input type="checkbox"/> 2	Working		CAM570	CAM570	0.0.8102.36	10.100.90.79:80	36:69:88:11:1...	[]:80
<input type="checkbox"/> 3	Working		FONE700	FONE700	0.0.8300.81	10.100.90.172:80	00:18:1a:60:3...	[]:80
<input type="checkbox"/> 4	Working		ProAV CAM-P1	ProAV CAM-P1	0.0.9900.09	10.100.90.63:80	00:18:1a:0c:b...	[]:80
<input type="checkbox"/> 5	Working		VB342 Pro	VB342 Pro	0.0.7804.06	10.100.90.68:80	00:18:1a:0c:b...	[]:80

The "Settings" section includes radio buttons for "DHCP" (selected) and "Static IP". To the right, there are input fields for "Start IP Address", "End IP Address", "Subnet Mask", "Gateway", and "Primary DNS". A checkbox at the bottom left is labeled "Don't start auto search this time!". An "Apply" button is located at the bottom right.

To access the web interface:

1. Download and install AVer IP Finder to your computer from AVer Download Center (<https://www.aver.com/download-center>) and launch the software.
2. Click **Search** to see available devices on the same local area network (LAN).

Note:

- Make sure your device is connected to the internet.
 - AVer IP Finder and your device must be on the same LAN.
3. Double-click on your device's IP address in the **IPv4 Address** column to open the web interface in your browser.

To change the network setting to DHCP or static IP:

1. Select the checkbox of your device.
2. Enter the default or changed password in the **Login** field.
3. Select **DHCP** or **Static IP**, then enter your network settings if applicable in the **Settings** section.
4. Click **Apply**.

Room Management

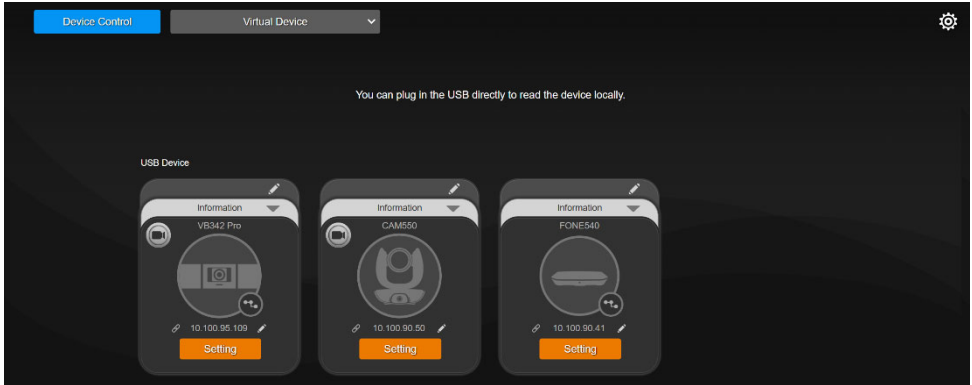

To access the web interface:

1. Download and install Room Management to your computer from AVer Download Center. (<https://www.aver.com/download-center>) and launch the software.

Note:

- Make sure your device is connected to the internet.
 - Room Management and your device must be on the same LAN.
 - Recommended browser: Chrome 76 and above, Firefox 69 and above.
2. Connect your device to your computer with the included USB cable. Your device should appear under the **Device Control** page.
 3. Click the **hyperlink** icon  on the device card to open the web interface in your browser.

To change the network setting to DHCP or static IP:

1. Click the **pencil** icon  on the device card.
2. Select **DHCP** or **Static IP**, then enter your network settings if applicable.
3. Click **Confirm**.

Log In for the First Time

When you log in for the first time, enter the default password **aver4321**. You will be prompted to set up a new account and password. The account and password cannot be the same.

- Account: Use 1-32 characters.
- Password: Use 8-32 characters and a combination of uppercase letters, lowercase letters, numbers, and symbols (! \$ % ' () * + , - . / < = > ? @ [\] ^ _ { } ~).

Web Interface

PTZ Control

Overview of PTZ Control

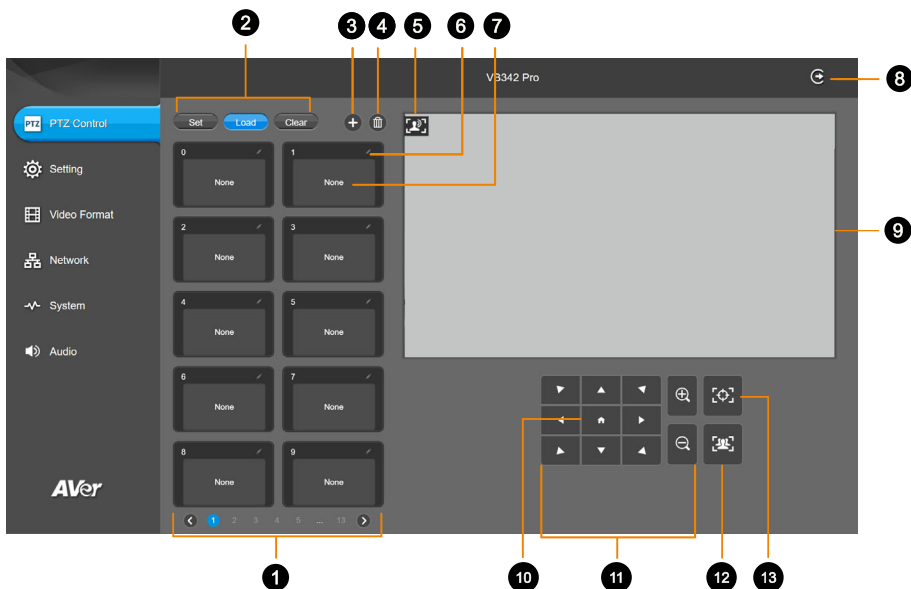

1. Presets 0-9

2. Preset Function Buttons

Save, load and clear a preset.

3. Add Available Presets

There are 10 available presets 0-9 by default. Click the plus icon to add up to 128 available presets.

4. Delete Available Presets

Click a trashcan icon to delete available presets.

5. Audio Tracking and Presentation Mode Icon

6. Name

Click the pencil icon to name a preset.

7. Preset Thumbnail

8. Log Out

Log out of your account and close the web interface.

9. Live View

10. Pan-Tilt Reset

Reset the pan-tilt position to the center.

11. Directional Pad and Zoom

12. SmartFrame

Click the SmartFrame icon  to frame entire group on screen.

Note: The SmartFrame icon  appears on video when turned on. To hide the icon, go to the **Setting** tab > **On-Screen Menu** > **Off** on the web interface.

13. One-Touch Focus

Click to autofocus once.

Save, Load and Clear a Preset



To save a preset:

1. Use the pan, tilt and zoom controls to position your camera.
2. Select **Set**, then a preset number to save that position.
3. Select **Yes** when prompted. A thumbnail of your preset will appear.

Add and Delete Available Presets (Presets 10-127)

There are 10 available presets 0-9 by default.

Click the plus icon to add up to 128 available presets, or click the trashcan icon to delete available presets.

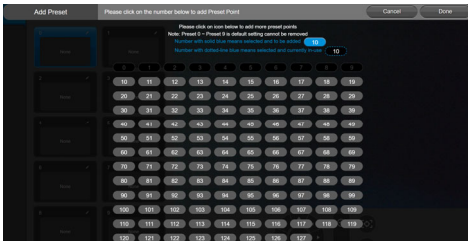

Add

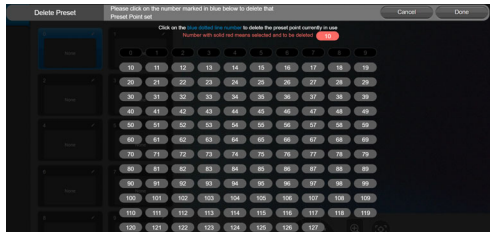

Delete

To add an available presets:

1. Select the plus icon, then select the preset numbers you want to add.
2. Select **Done**.

To delete an available preset:

1. Select the trashcan icon, then select the preset numbers you want to delete.
2. Select **Done**.

Setting

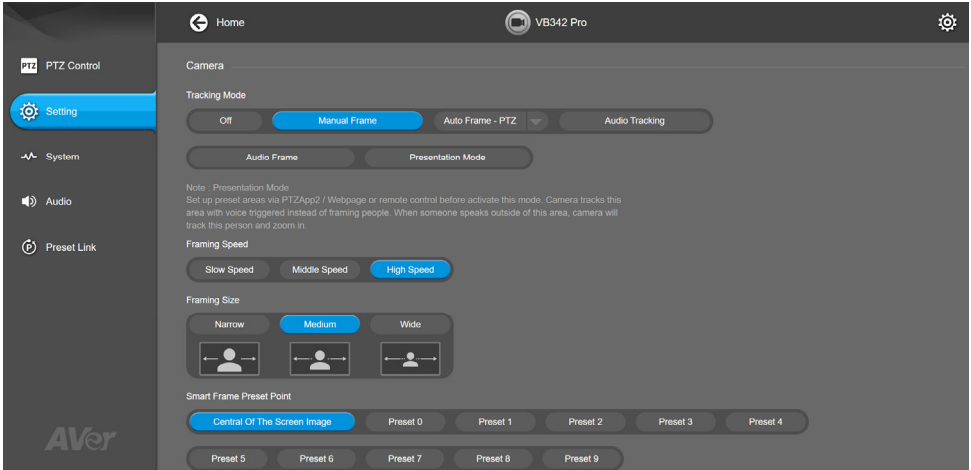

Camera

Item	Description
Tracking Mode	Select a tracking mode. Refer to < Tracking Mode > for details.
Framing Speed	Select a duration before auto frame. <ul style="list-style-type: none"> • Slow: 5 seconds before auto frame. • Middle: 3 seconds before auto frame. • High: 1 second before auto frame.
Framing Size	Select a framing size to include or remove excess space on either side of the subject.
SmartFrame Preset Point	Select a position as the detection area when using SmartFrame to frame entire group on screen.
Audio Tracking Response Speed	Select an audio tracking response speed. Slower response speeds can be useful for ignoring short utterances during audio tracking. <ul style="list-style-type: none"> • Slow Speed: 4 second before audio tracking. • Middle Speed: 2 seconds before audio tracking. • High Speed: Fastest audio tracking response speed.
Audio Tracking Idle Interval	Select a duration for the camera to frame entire group after it detects no sound. If Off is selected, the camera will stay at the last position.
Gesture Control	Turn Gesture Control on or off. <ul style="list-style-type: none"> • The effective distance is up to 5 meters. • Click the question mark icon to see a list of gesture commands or refer to <Gesture Control> for details.

Audio Fence	<p>When Audio Fence is turned on:</p> <ul style="list-style-type: none"> • Select a narrow or wide audio fence to capture only the voices within it. • You won't be able to use pan, tilt, zoom controls, SmartFrame and tracking modes.
Audio Fence Mode	
Autofocus	Automatically focus after each pan, tilt and zoom, or automatically focus continually.
Camera Focus	Adjust the focal length manually by dragging the slider or automatically.
Home Position	Select a home position that your camera moves to when powered on.
Sleep Position	Select a home position that your camera moves to when entering standby mode.
Sleep Timer	<p>Set a duration before standby mode.</p> <ul style="list-style-type: none"> • When transmitting video over USB, RTSP or RTMP, the camera won't enter standby mode.
On-Screen Menu	<p>Turn On-Screen Menu on or off.</p> <ul style="list-style-type: none"> • Off: Displays no icons or notifications. • On: Displays icons or notifications. • Load Preset Off: Displays all icons and notifications except load preset.
Save Preset	<p>Turn Save Preset on or off.</p> <ul style="list-style-type: none"> • When Save Preset is turned off, you won't be able to save presets using the remote control, web interface, hotkeys or VISCA commands.

Image

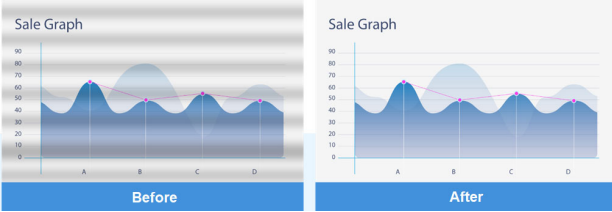
Item	Description
Image Flip	Flip the image vertically.
Image Mirror	Flip the image horizontally.
True WDR	Turn True Wide Dynamic Range (WDR) on or off.
Flicker Decrease on IFP / Monitor	Turn Flicker Decrease on IFP / Monitor on or off. 
Frequency	Select a frequency.
White Balance	Select a white balance setting: <ul style="list-style-type: none"> • Manual: Adjust the white balance manually by dragging the slider. • Auto: Adjust the white balance automatically.
Noise Reduction	Select a noise reduction level.
Brightness	Select a brightness level.
Sharpness	Select a sharpness level.
Saturation	Select a saturation level.
Low Light Compensation	Turn Low Light Compensation on or off.
Low Resolution under 720p (except 848*480)	Enable to transmit video in 720p or lower.
Enlarge Total Zoom Up to 15x	Enable or disable Enlarge Total Zoom Up to 15x.
Video Frame Rate	Select a video frame rate.

RS-232

Item	Description
ADDR	Select your settings to set up an RS-232 connection.
Baud Rate	
Protocol	
VISCA over IP	

Overview of the Floating Live View

- The floating live views opens automatically in the **Setting, Video Format, Network** and **System** tabs.
- To open the floating live view again after closing, click on the camera icon on top of **Setting, Video Format, Network** and **System** tabs.

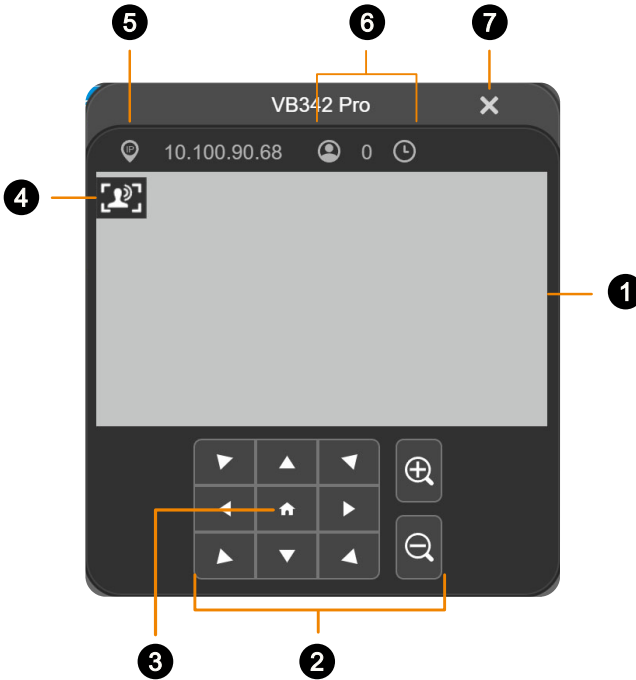

1. Live View

2. Directional Pad and Zoom

3. Pan-Tilt Reset

Reset the pan-tilt position to the center.

4. Audio Tracking and Presentation Mode Icon

5. IP Address

6. Head Count and Video Transmission Duration

Click the head count icon to display head count and the duration of your video transmission. Click the icon again to hide the information.

7. Close

Click the X icon to close the floating live view and stop transmitting video.

Tracking Mode

Manual Frame

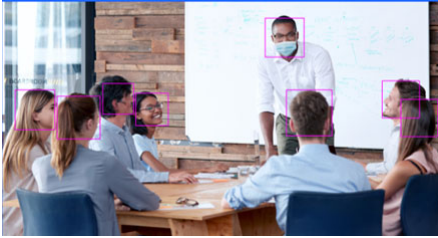

Frames manually using the SmartFrame button  to frame entire group on screen once.

Auto Frame

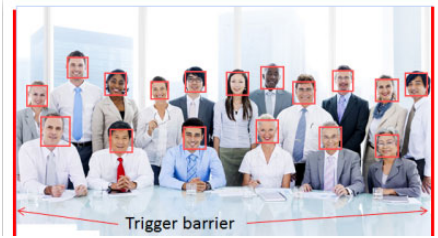

Frames entire group on screen automatically using true pan, tilt and zoom (True PTZ) or electronic pan, tilt and zoom (ePTZ).

If no one is in view, the camera will default to preset 0.

- The camera auto frames every time a subject enters or leaves the screen.
- If Auto Frame happens too frequently, set a duration before auto frame in the **Setting** tab > **Framing Speed**.

Audio Tracking (True PTZ)

Frames active speaker on screen.

If no one is speaking, the camera will stay at the last position or default to group framing after your selected **Audio Tracking Idle Interval**.

- You can set a duration before the camera default to group framing in the **Setting** tab > **Audio Tracking Idle Interval**.
- You can select a group framing detection area in the **Setting** tab > **SmartFrame Preset Point** (defaults to the center of the screen).

Audio Frame (ePTZ)

Frames active speaker on screen.

If no one is speaking, the camera will stay at the last position or default to group framing after your selected **Audio Tracking Idle Interval**.

- You can set a duration before the camera default to group framing in the **Setting** tab > **Audio Tracking Idle Interval**.
- You can select a group framing detection area in the **Setting** tab > **SmartFrame Preset Point** (defaults to the center of the screen).

Presentation Mode

A combination of presets (not Preset Framing) and Audio Tracking.

Uses presets when active speaker is speaking inside of presets; uses Audio Tracking and frames active speaker on screen when they are speaking outside of presets.





If no one is speaking, the camera will stay at the last position or default to group framing after your selected Audio Tracking Idle Interval.

- Make sure you have defined presets for audio tracking. Presets 1-9 are available. Preset 0 defaults to the home position.
- You can set a duration before the camera default to group framing in the Setting tab > Audio Tracking Idle Interval.
- You can select a group framing detection area in the **Setting** tab > **SmartFrame Preset Point** (defaults to the center of the screen).

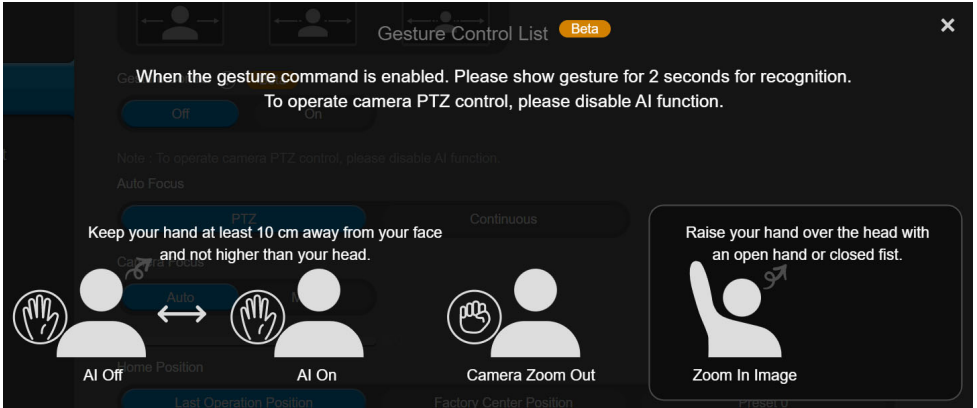
Gesture Control

- Turn on Gesture Control in the **Setting** tab > **Gesture Control**.
- The effective distance is up to 5 meters.



Gesture	Description
 <p data-bbox="76 906 320 930">Turn Auto Frame on or off</p>	<p data-bbox="353 762 1009 850">Place your hand next to your face with your palm open and facing the camera for 2-3 seconds to turn Auto Frame on or off. Keep your hand 10cm away from your face.</p>
 <p data-bbox="76 1104 154 1128">Zoom In</p>	<p data-bbox="353 957 910 981">Raise your hand over your head for 2-3 second to zoom in.</p> <ul data-bbox="353 1013 1031 1257" style="list-style-type: none"> • Tracking Mode will be turned off when you zoom in or out with gestures. To turn on Tracking Mode again, do one of the following: <ol data-bbox="389 1104 1031 1257" style="list-style-type: none"> 1. Use gesture to turn on Auto Frame. 2. Long press the SmartFrame button  on the remote control to switch between tracking modes. 3. Web interface: go to the Setting tab > Tracking Mode. 4. Room Management: go to the Setting tab > Tracking Mode.
 <p data-bbox="76 1407 171 1431">Zoom Out</p>	<p data-bbox="353 1264 1020 1319">Place your fist next to your face with your fist facing the camera for 2-3 seconds to zoom out. Keep your fist 10cm away from your face.</p> <ul data-bbox="353 1351 1031 1495" style="list-style-type: none"> • Tracking Mode will be turned off when you zoom in or out with gestures. To turn on Tracking Mode again, do one of the following: <ol data-bbox="389 1441 1031 1495" style="list-style-type: none"> 1. Use gesture to turn on Auto Frame. 2. Long press the SmartFrame button  on the remote control to

switch between tracking modes.

3. Web interface: go to the **Setting** tab > **Tracking Mode**.

4. Room Management: go to the **Setting** tab > **Tracking Mode**.

Video Format

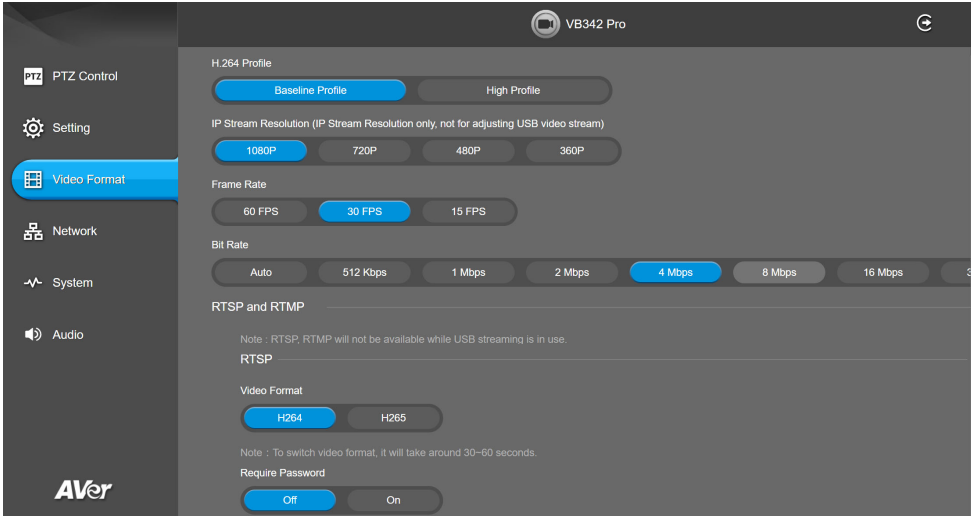

Item	Description
H.264 Profile	Select a profile for streaming live.
IP Stream Resolution	Select a resolution for streaming over IP.
Frame Rate	Select a frame rate.
Bit Rate	Select a bit rate. <ul style="list-style-type: none"> To live stream on Facebook, we recommend a bit rate under 4Mbps.

RTSP and RTMP

Item	Description	
RTSP	Video Format	Select a video format.
	Require Password	Turn Require Password on or off.
	Set RTSP Access Password	Set or change an RTSP access password.
	RTSP URL Address	Displays RTSP URL address.
RTMP	Server URL	Copy and paste your video platform's server URL and stream key.
	Stream Key	
	Start Using RTMP	Click Start to start streaming, Stop to stop streaming.

Network

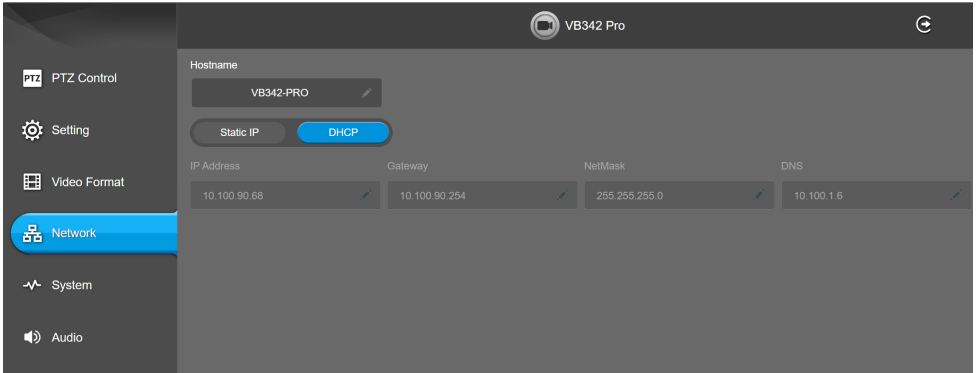

Item	Description
Hostname	Click the pencil icon to edit a hostname. Use upper and lowercase letters and numbers.
Static IP, DHCP	Set up static IP or DHCP. If Static IP is selected, enter your network settings to set up a static IP connection and click Confirm .

System

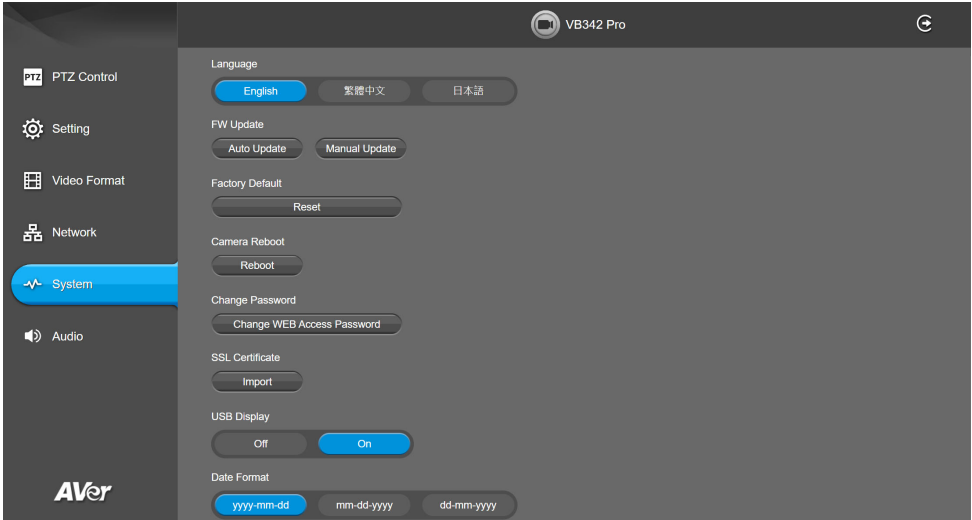

Item	Description
Language	Select a language for the web interface.
Firmware Update	Update your camera's firmware. <ul style="list-style-type: none"> • Auto Update: Checks and updates online. • Manual Update: Update the firmware using a file offline. <p>Note: The camera will reboot and the connection will be lost. Please wait a few minutes and keep the power cable connected. Unplugging the cable during this process may damage the device.</p>
Factory Default	Reset your camera to factory default settings. You can choose to keep the IP address by selecting the checkmark. <ul style="list-style-type: none"> • If you forgot your password, use Room Management to reset the web interface password to the default aver4321.
Camera Reboot	Reboot the camera.
Change Password	Change the web interface password. Refer to < Log In for the First Time >. <ul style="list-style-type: none"> • If you forgot your password, use Room Management to reset the web interface password to the default aver4321.
SSL Certificate	Upload an SSL certificate.
USB Display	The HDMI output port supports USB display. Turn USB display on or off.
Date Format	Select a date format.
Time Format	Select a time format.
Time Correction Mode	Select a time correction mode.

	<ul style="list-style-type: none"> • Auto: Enter your Network Time Protocol (NTP) server URL to synchronize the clock. The default NTP server is located in the US. • Manual: Click the pencil icon to set up the clock.
Allow Providing of Anonymous Usage Data	Opt-in or opt-out of providing usage data.
Information	Displays your camera information such as IP address.

Audio

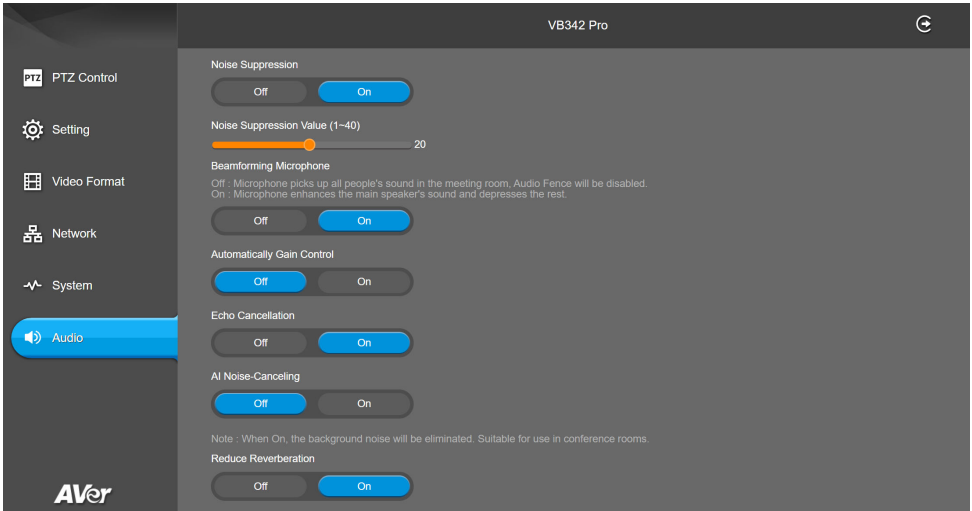

Item	Description
Nosie Suppression	Reduce ambient noise. Adjust the noise suppression value by dragging the slider.
Beamforming Microphone	Reinforce active speaker's voice and reduce ambient noise.
Automatically Gain Control	Turn automatic gain control on or off.
Echo Cancellation	Reduce echoes.
AI Noise-Canceling	Reduce the sound of keyboard typing.
Reduce Reverberation	Reduce reverberation within a room.
Phone In Jack	Select an option based on the device connected to the phone in port and use case: <ul style="list-style-type: none"> • Phone In: Connect a phone to communicate with remote participants. • 3.5 mm Microphone Only: Use only your connected external microphones as audio source. • 3.5 mm Microphone Mix In: Use both the expansion speakerphone and your connected external microphones as audio source. • Line Out: Designed for hearing augmentation system. <ul style="list-style-type: none"> - Please purchase an audio-out adapter (TRS female to TRRS male) from AVer. - Do not connect external speakers. Doing so may interfere with the built-in speakes and microphones.

Room Management

Configure Settings on Room Management

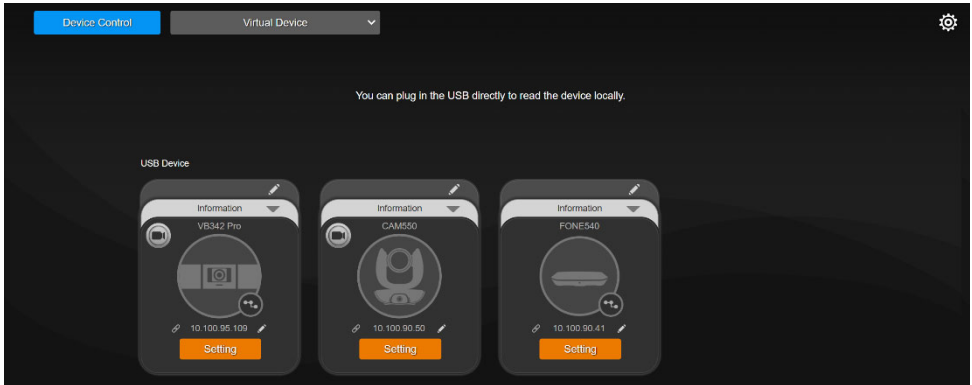

1. Download and install Room Management to your computer from AVer Download Center. (<https://www.aver.com/download-center>) and launch the software.
2. Connect your device to your computer using the included USB cable. Your device should appear under the **Device Control** page.
3. Click **Setting** to control video and audio settings.

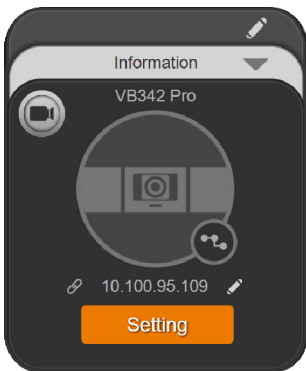

EZLive

Please go to <https://www.aver.com/download-center> to download the AVer EZLive software. After downloading, double-click on the file and follow the on-screen instructions to complete the installation.

During a video call, EZLive can help user to do:

- (1) Camera ePTZ
- (2) Volume control for the speaker connected
- (3) Capture camera's still images
- (4) Record video
- (5) Live stream to YouTube, Livehouse.in, USTREAM, etc.
- (6) Camera Zoom in/out
- (7) Capture PC screen shot
- (8) Record PC screen video
- (9) Set up livestream
- (10) Open file management to retrieve photos and video files
- (11) Livestream setting
- (12) Drawing tool.

