

AVer PTZ Link

— **User Manual** —

DISCLAIMER

No warranty or representation, either expressed or implied, is made with respect to the contents of this documentation, its quality, performance, merchantability, or fitness for a particular purpose. Information presented in this documentation has been carefully checked for reliability; however, no responsibility is assumed for inaccuracies. The information contained in this documentation is subject to change without notice.

In no event will AVer Information Inc. be liable for direct, indirect, special, incidental, or consequential damages arising out of the use or inability to use this product or documentation, even if advised of the possibility of such damages.

TRADEMARKS

“AVer” is a trademark owned by AVer Information Inc. Other trademarks used herein for description purpose only belong to each of their companies.

COPYRIGHT

© 2025 AVer Information Inc. All rights reserved. | August 29, 2025

All rights of this object belong to AVer Information Inc. Reproduced or transmitted in any form or by any means without the prior written permission of AVer Information Inc. is prohibited. All information or specifications are subject to change without prior notice.

More Help

For FAQs, technical support, software and user manual download, please visit:

Non-USA

Download Center: <https://www.aver.com/download-center>

Technical Support: <https://www.aver.com/technical-support>

USA

Download Center: <https://www.averusa.com/education/support>

Technical Support: <https://averusa.force.com/support/s/contactsupport>

Contact Information

Headquarters

AVer Information Inc.
8F, No.157, Da-An Rd.,
Tucheng Dist., New Taipei City
236042, Taiwan
Tel: +886 (2) 2269 8535

USA Branch Office

AVer Information Inc., Americas
44061 Nobel Drive, Fremont,
CA 94538, USA
Tel: +1 (408) 263 3828
Toll-free: +1 (877) 528 7824

Europe Branch Office

AVer Information Europe B.V.
Westblaak 134, 3012 KM,
Rotterdam, The Netherlands
Tel: +31 (0) 10 7600 550

Japan Branch Office

アバー・インフォメーション
株式会社
〒160-0023 日本東京都新宿区
西新宿 3-2-26 立花新宿ビル 7
階
Tel: +81 (0) 3 5989 0290
お客様サポートセンター(固定電
話のみ): +81 (0) 120 008 382

Vietnam Branch Office

Công ty TNHH AVer
Information
(Việt Nam)
Tầng 5, 596 Nguyễn Đình
Chiểu, P.3, Quận 3, Thành phố
Hồ Chí Minh 700000, Việt Nam
Tel: +84 (0) 28 22 539 211
Hỗ trợ kỹ thuật: +84 (0) 90 70
080 77

Korea Office

한국 에버 인포메이션 (주)
서울시 종로구 새문안로 92
(신문로 1가,
광화문오피시아빌딩) 1831,
1832 호
Tel: +82 (0) 2 722 8535

Contents

Overview	1
Compare Versions and Features.....	1
System Requirements	1
Supported AVer Devices.....	2
Supported Microphones	3
Audio-Technica.....	3
Biamp.....	7
Bosch.....	11
ClearOne.....	16
Nureva	19
Sennheiser.....	23
Shure	26
Yamaha.....	31
Install AVer PTZ Link.....	32
Minimize and Quit AVer PTZ Link.....	32
Connections	33
Get Started	34
User Interface.....	34
Device Group List.....	35
Add Devices	37
Assign a Priority Group	39
Set a Preset	40
IP Cameras	40
USB Cameras	41
Set up Voice Tracking	43
Channel Mode.....	43
Multiple Speakers Mode Conditions.....	46

Active Position (Premium).....	47
Supported Devices.....	47
Square Microphone Calibration.....	48
Round Microphone Calibration.....	53
Add a Coverage Area.....	56
AVer PTZ Link System Settings.....	58
System.....	58
License.....	60
Camera Setting.....	63
HTTP Request.....	64
Help Center.....	65
About.....	65
Privacy Policy.....	65
Troubleshoot.....	66

Overview

AVer PTZ Link is an application software that connects AVer cameras to third-party microphone systems (supported models) from Audio-Technica, Biamp, Bosch, ClearOne, Nureva, Sennheiser, Shure to Yamaha.

It provides IP- and USB-based control and enables users to turn AVer cameras into voice-tracking cameras by setting presets. It also enables users to create virtual cameras, perform automatic video switching, as well as tracking the presenter when human tracking is enabled in the Premium version.

Compare Versions and Features

	Free	Premium (60-Day Free Trial)
IP connectivity	✓	✓
USB connectivity (Windows only)	✓	✓
Virtual camera (Windows only)		✓
Automatic video switching (Windows only)		✓
Active position (Windows only)		✓
Human tracking		✓
AVer camera + microphone groups	5	25
Microphone channels	8	128
Presets	256	256

System Requirements

	Minimum	Recommended
OS	Windows 7 (64-bit) or later macOS 10 or later	Windows 7 (64-bit) or later macOS 10 or later
CPU	Intel Core i5 10th Generation	Intel Core i7-10875H or greater
GPU		NVIDIA GeForce RTX 2070 or greater
RAM	8 GB	16 GB DDR4 or greater
Free storage space	800 MB	800 MB

Supported AVer Devices

Professional Tracking Cameras

- Single Lens

TR211	TR311HWV2	TR310
TR315	TR313V2	TR311
TR315N	TR323V2	TR311HN
TR335	TR323NV2	TR313
TR335N	TR333V2	TR331
TR615	PTC310HWV2	TR333
	PTC310UV2	PTC310
	PTC320UV2	PTC310N
	PTC320UNV2	PTC310U
	PTC330UV2	PTC330
		PTC330U

- Dual Lens

TR535	TR530+
TR535N	PTC115+
	PTC500+

Professional PTZ Cameras (Do not support human tracking)

PTZ211	PTZ310
PTZ231	PTZ310N
PTZ310UV2	PTZ310W
PTZ310UNV2	PTZ330
PTZ330UV2	PTZ330N
PTZ330UNV2	PTZ330W

Video Conferencing Cameras (Do not support active position)

CAM520 Pro2	VC520 Pro3
CAM520 Pro3	VC550
CAM550	
CAM570	

Distance Learning Camera

DL30

Important Note on Voice Tracking Installation

When installing voice tracking systems, consider the environment, materials, and distances to ensure optimal performance. Assess the room size, layout, and acoustics, as these factors impact accuracy. Different surfaces affect sound reflection and absorption, influencing effectiveness. Measure and maintain appropriate distances between devices and the coverage area for clear tracking. To achieve the best experience, connect with an AVer technical expert who can tailor the installation to your specific needs.

Supported Microphones

Third-party microphone systems may require setup in their manufacture software.

Audio-Technica

ATND1061LK/DAN

ATUC-50

ATUC-IR

To set up ATND1061LK/DAN Beamforming Ceiling Array Microphone:

1. Open Digital Microphone Manager. Go to **Settings & Maintenance**  > **System Settings** > **Network** > **IP Control Settings**.
2. Turn on **Notification** and **Camera Control Notification**.

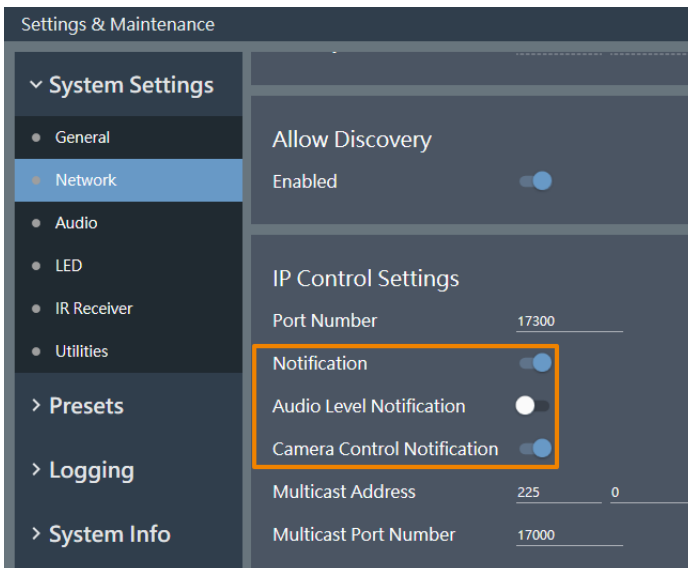

3. Select a microphone in the main area.
4. Go to **Camera > Camera Area**. Add a Camera Area by dragging it within the microphone pickup area. Each Camera Area group corresponds to AVer PTZ Link channel 1-8.

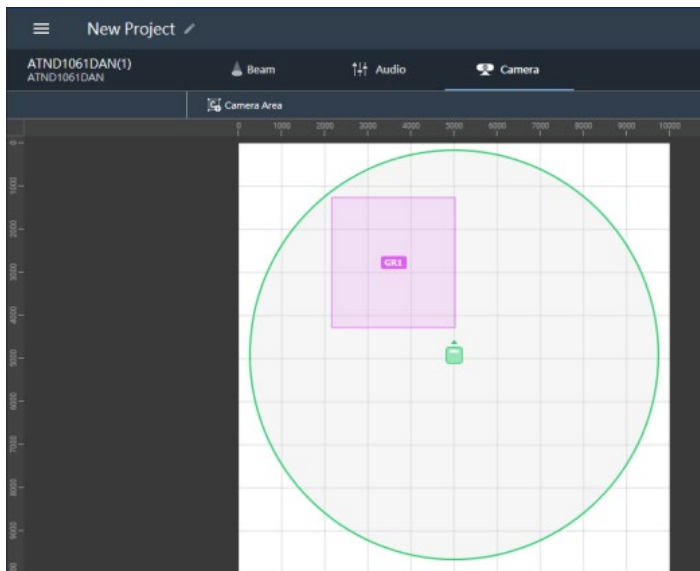

To set up ATUC-IRCU infrared control unit:

1. On the ATUC-IRCU Web Remote interface, go to **Settings & Maintenance > System Settings > Network > IP Control Settings**.
2. Turn on **Notification**.

Note: If a powered-off ATUC-IRDU appears to be sending audio signal in AVer PTZ Link, turn on **Audio Level Notification** to resolve the issue.

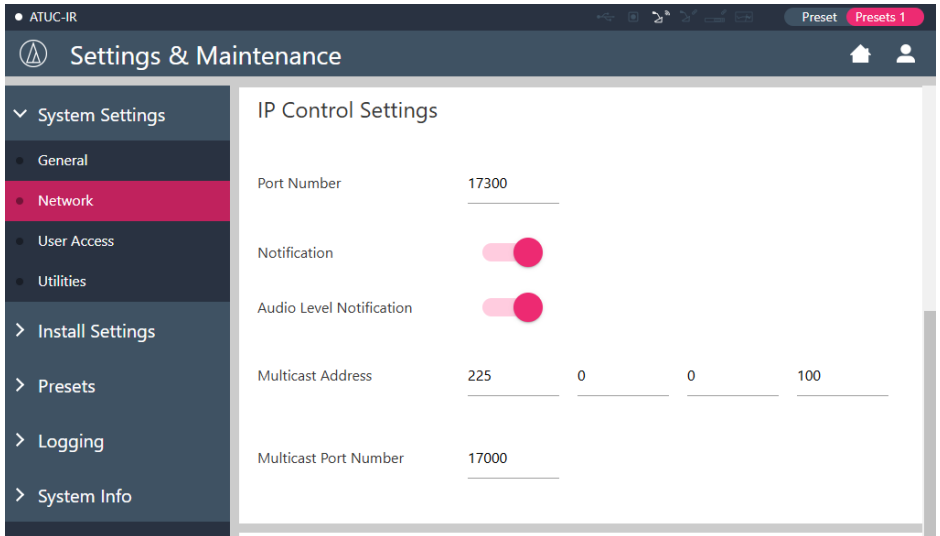

To pair ATUC-50 / ATUC-IR with AVer camera presets:

- Each ATUC-50DU or ATUC-IRDU discussion unit corresponds to an AVer PTZ Link channel.
- A discussion unit whose talk button is pressed first takes priority over others until it is mute. For example, Channel 1 (pressed first) takes priority over Channel 2 whose talk button is also pressed.

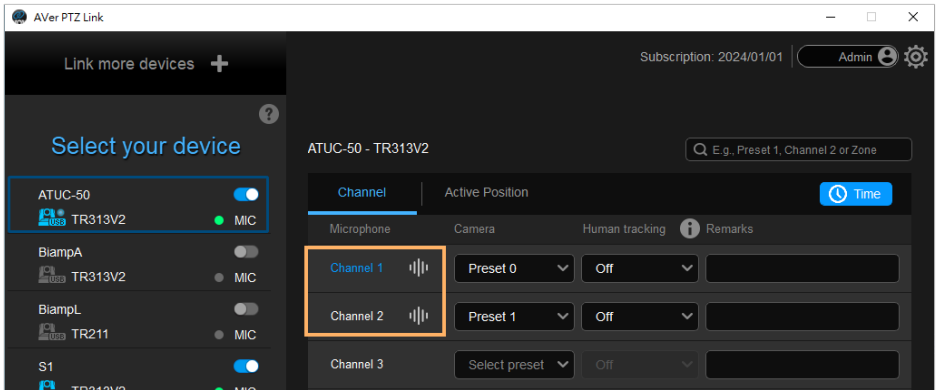

Biamp

Tesira Digital Signal Processor

Parlé Ceiling Microphones (requires Parlé product revision A or B)

Hardware and Channels Overview

Tesira Digital Signal Processor	Tesira Forte X, Tesira Forte Rackmount, Tesira Server IO, Tesira Server.
Parlé TCM-X	Plenum network box + one ceiling-mount microphone array
Parlé TCM-XA	Plenum network box with built-in amplifier+ one ceiling-mount microphone array
Parlé TCM-XEX	One expansion ceiling-mount microphone array

Up to 2 ceiling microphone arrays are permitted per network box (one TCM-X or TCM-XA with TCM-XEX).

Each ceiling microphone array has 8 channels. PTZ Link divides the microphones' horizontal angles into 8 equal parts, which correspond to PTZ Link Channel 1–8.

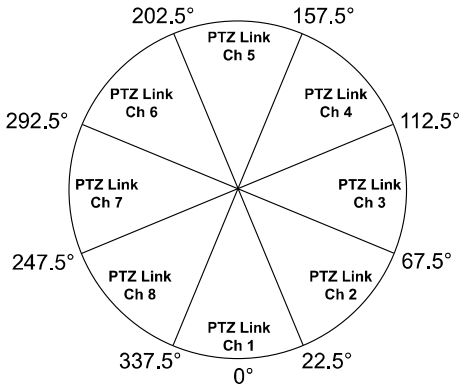

Microphone	Channel Start/End
AVerParleMic1	1-8 (ceiling mic 1) 9-16 (ceiling mic 2)
AVerParleMic2	17-24 (ceiling mic 1) 25-32 (ceiling mic 2)
AVerParleMic3	33-40 (ceiling mic 1) 41-48 (ceiling mic 2)
AVerParleMic4	49-56 (ceiling mic 1) 57-64 (ceiling mic 2)
AVerParleMic5	65-72 (ceiling mic 1) 73-80 (ceiling mic 2)
AVerParleMic6	81-88 (ceiling mic 1) 89-96 (ceiling mic 2)

To enable system security:

You can protect 3rd party media control access for the Tesira system using username and password.

1. After the DSP has been configured, connect to the unprotected Tesira system with Tesira Designer Software.
2. Open the **System** menu > **Security** menu > **Manage System Security...**
3. Click the **Protect System...** button to create the admin user and password.

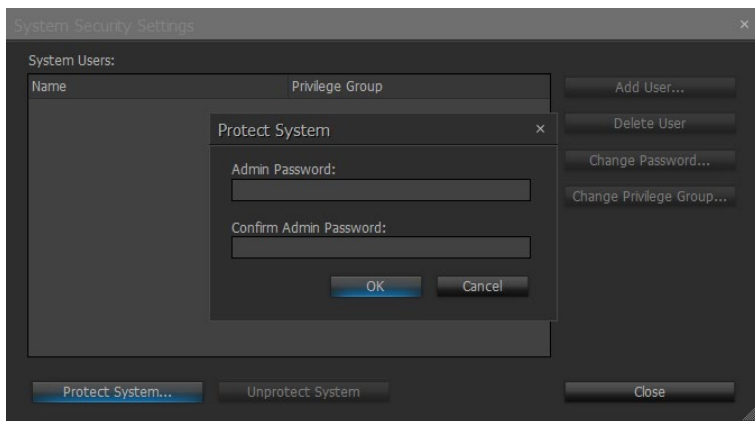

4. You'll be prompted to enter the same set of username and password when connecting to Biamp microphones in PTZ Link.

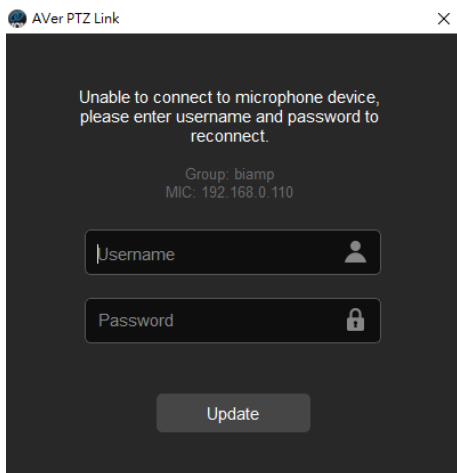

To set up Parlé TCM-X microphones:

1. Open Tesira Design Software.
2. After the TCM-X microphone has been added to the layout, the instance tag of the Parlé microphone block or Logic Meter block to be controlled must use the following naming schemes.

To check or rename the instance tag of a specific block, click on that block, go to **Properties** panel > **DSP Properties** tab > **Instance Tag**.

- Parlé microphone block: **AVerParleMicX** (X=1–6 starting with 1)

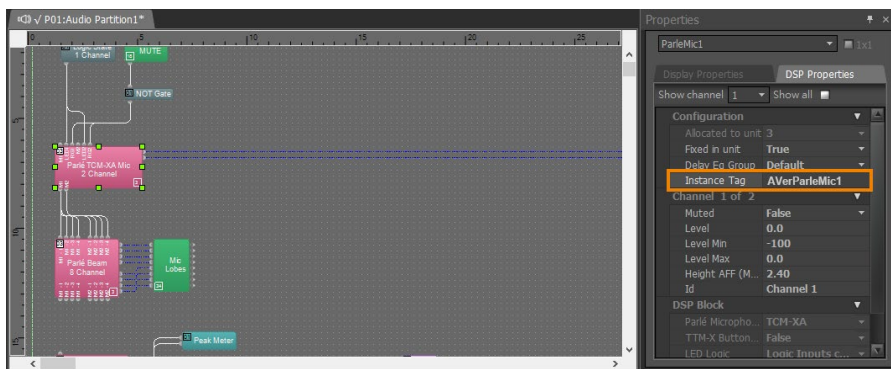

- Logic Meter Parle Processing active mic output: **AVerActiveMic**

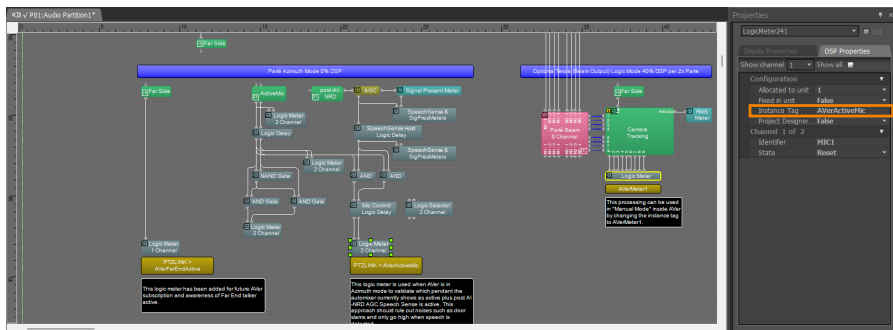

- Logic Meter block: **AVerMeterX** (X=1–4 starting with 1)

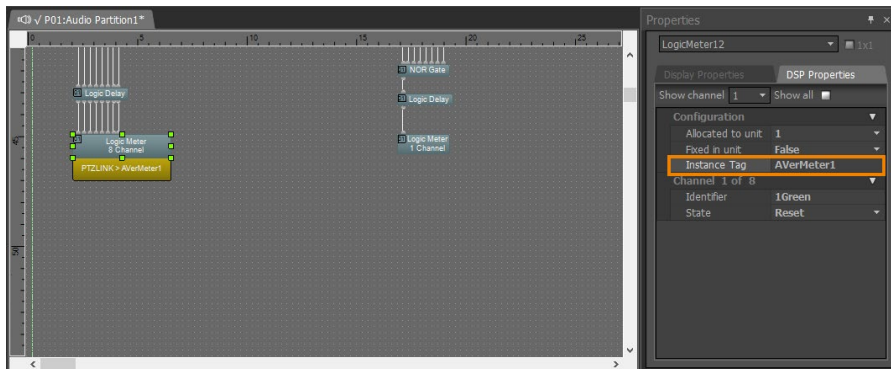

3. Click **Channel Configure** and select a pickup mode in AVer PTZ Link. Then click **Save**.

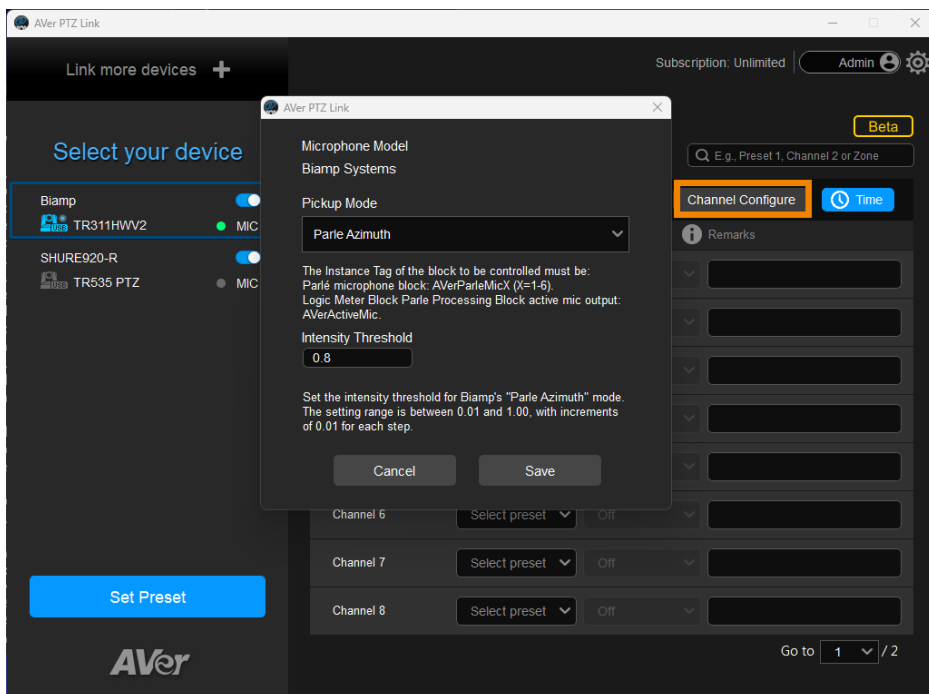

Bosch

CCS 1000 D Digital Discussion System

DICENTIS Conference System

DICENTIS Wireless Conference System

- Each CCS 1000 D Control Unit supports up to 80 Discussion Devices.
- Assign each CCS 1000 D Discussion Device to one AVer PTZ Link channel by changing the seat name.
- A discussion unit whose talk button is pressed first takes priority over others until it is mute. For example, Channel 1 (pressed first) takes priority over Channel 2 whose talk button is also pressed.

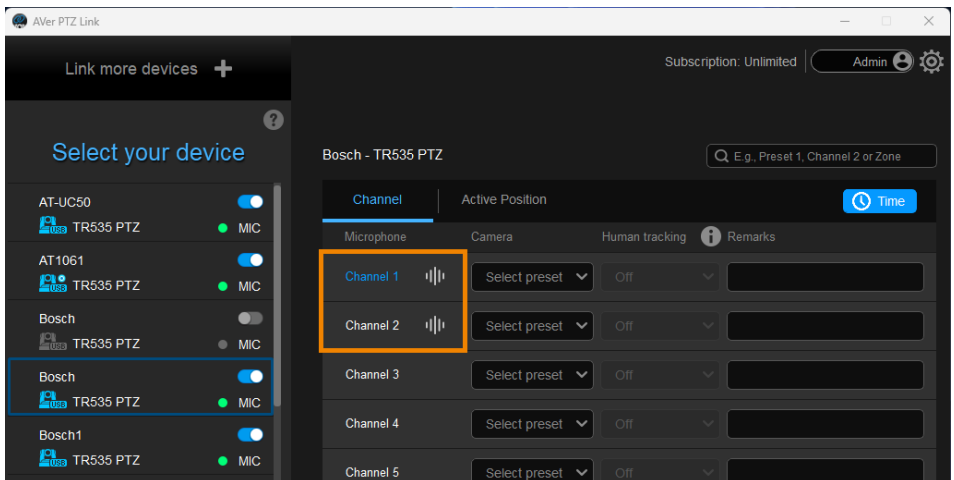

To set up CCS 1000 D:

1. Connect to the CCS 1000 D Control Unit via IP. Access the web interface with an administrator account.
2. Go to **System Settings > Users**, create a user for AVer PTZ Link with the default username/password **ptzlink/ptzlink**. The password can be changed later. For **User rights**, select **Manage meeting**.

The screenshot shows the 'User settings' page with a list of users. A plus sign icon is circled in orange, indicating the 'Add new user' action. Below it, the 'Add new user' modal is open, showing the following fields and options:

First name	<input type="text" value="AVer"/>	User rights:	<input type="button" value="Manage meeting"/>	<input type="button" value="Configure"/>
Last name	<input type="text" value="Information"/>		<input type="button" value="Prepare meeting"/>	<input type="button" value="Prepare system"/>
Username	<input type="text" value="ptzlink"/>		<input type="button" value="Modify users"/>	
Password	<input type="text" value="ptzlink"/>			
Confirm password	<input type="text" value="ptzlink"/>			

Buttons: Cancel, Save, Change password

3. Go to **System Settings > Network and general settings > General settings**, deselect **Automatically shut down the system when not used** to avoid entering standby mode.

The screenshot shows the 'Network and general settings' page. The 'General settings' section is highlighted with an orange box, showing the following option:

<input type="checkbox"/> Automatically shutdown the system when not used
--

Buttons: Change network settings, Factory default

4. Go to **System Settings > Seats**, rename the **Seat name** ending with a space and a number to assign each discussion device to one PTZ Link channel of the same number.

Seat settings

(2-2)	Seat name	Mode	Camera	Pre-position
<input type="checkbox"/>	Seat 1	Normal	None	
<input type="checkbox"/>	Seat 2	Normal	None	

Selection mode

Home Back

Seat 1 corresponds to channel 1, seat 2 to channel 2, and so on.

- You'll be prompted to enter the same set of username and password when connecting to Bosch microphones in AVer PTZ Link.

Note:

CCS 1000 D Control Unit allows one login at a time. When connecting CCS 1000 D Discussion Devices to AVer PTZ Link, make sure you are not logged in anywhere else.

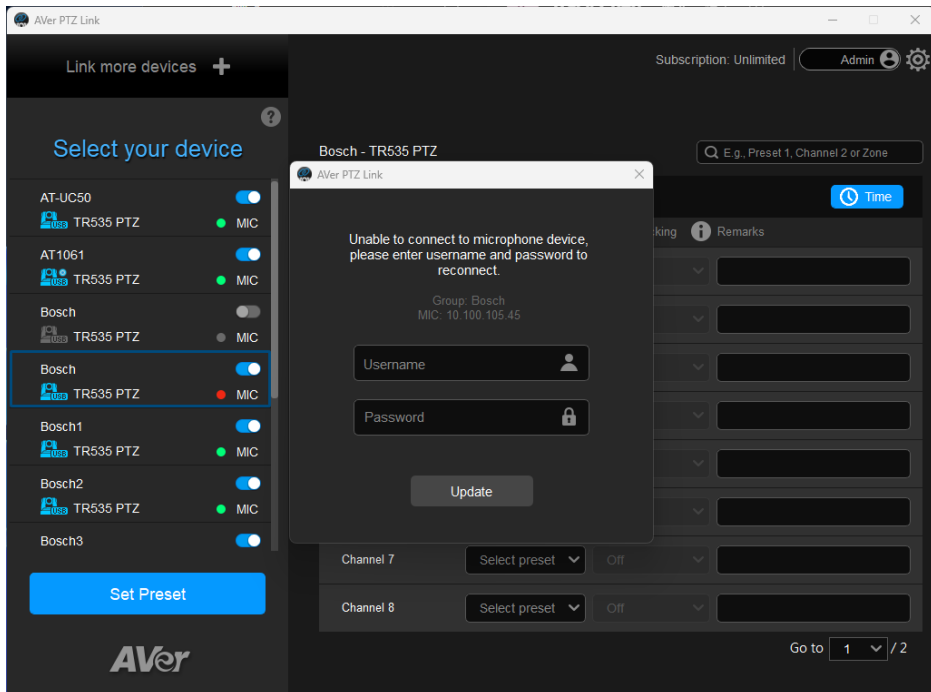

- **To log in to DICIENTIS System Server:**

1. Open **Remote Desktop Connection** on your computer. Enter the DICIENTIS server name printed on the product label.

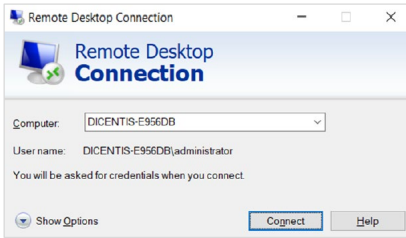

2. Enter the credentials you purchased from Bosch. On security message pop-up window, click **Yes**.

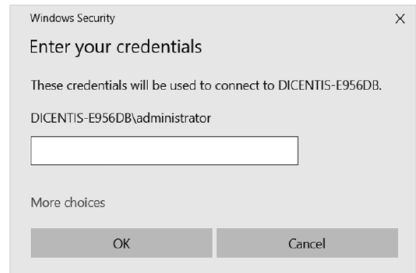

3. Open **Bosch Meeting Application**, enter your credentials to log in. Go to **Configure** for further meeting room and user settings.



4. Click **Users** and click the Add icon to add a new user. In **Security**, select **Admin** as the User group, and then click **Change Password**.

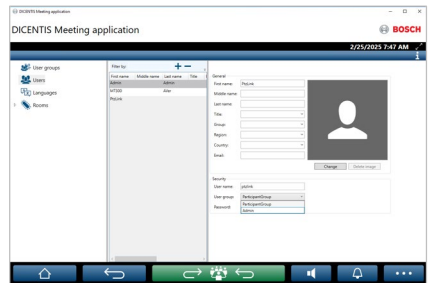

5. Enter the default password: **ptzlink**. When finished, click **OK**.

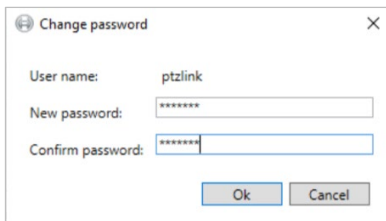

6. Go to **Rooms > Seats and devices** to assign each microphone to MT300 channels. Seat 1 corresponds to channel 1, seat 2 to channel 2, and so on.

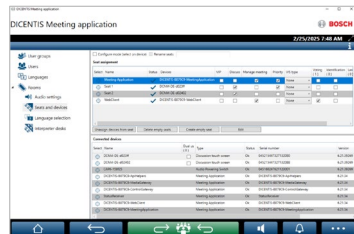

ClearOne

BMA 360 + CONVERGE® Pro 2 DSP Mixers

- CONVERGE® Pro 2 connects up to 3 daisy-chained BMA 360 microphone arrays.
- AVer PTZ Link assigns 12 channels to each BMA 360. Unused channels are retained in the assigned BMA 360.

Daisy-Chained	Channel Start/End
1 st BMA 360	1-12
2 nd BMA 360	13-24
3 rd BMA 360	25-36

- When adding your device in PTZ Link, select your MIC channels in the drop-down list according to the number of BMA 360 daisy-chained.

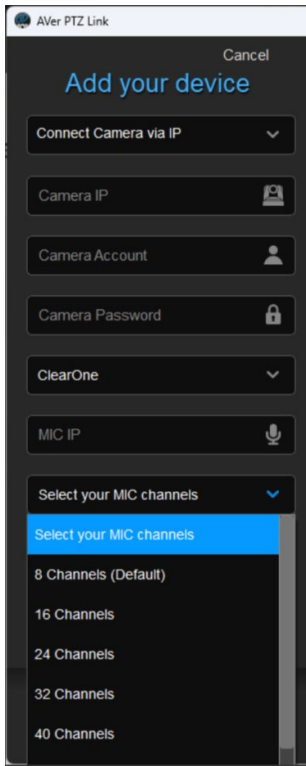

BMA 360D

- Use CONSOLE AI Lite software to select preset beam patterns for common room or custom pattern for unique floorplans of up to 12 beams.
- Each microphone beam corresponds to one PTZ Link channel of the same number.

BMA 360DX

- Use CONSOLE ONE software to select preset beam patterns for common room or custom pattern for unique floorplans of up to 12 beams.
- After connecting, select **Channel Properties**, then click **DX** next to **Beamformer**.

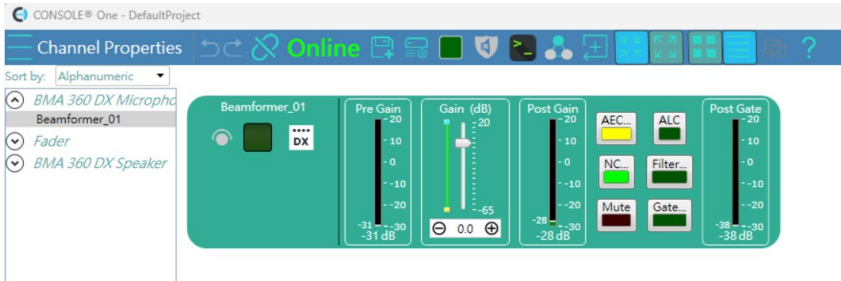

- Click **Advanced**. Clear the check box for **Last Beam On** to disable this function. Otherwise, the Focused Channel will remain on the last channel and will not disappear even when no sound is detected.
- Each microphone beam corresponds to one PTZ Link channel of the same number.

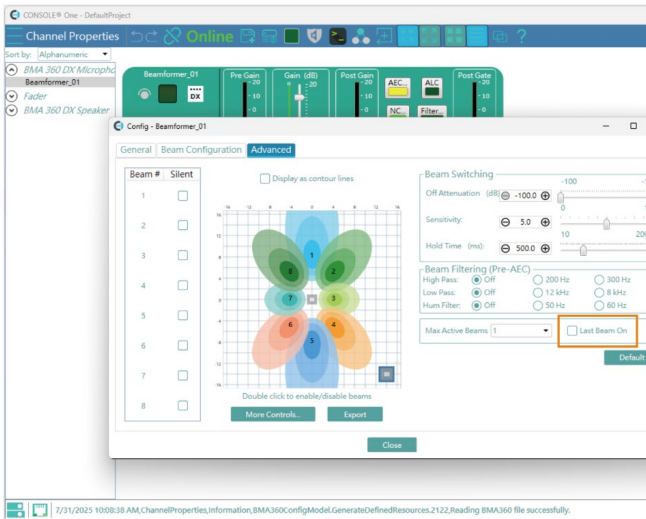

Nureva

HDL300

HDL310

Dual HDL300

HDL410

To set up HDL microphones:

- Nureva Console Client:
 1. Turn on **Enable camera tracking integration**.
 2. Enter the IP address of the computer running AVer PTZ Link in the **Allowed host names / IP addresses** field.

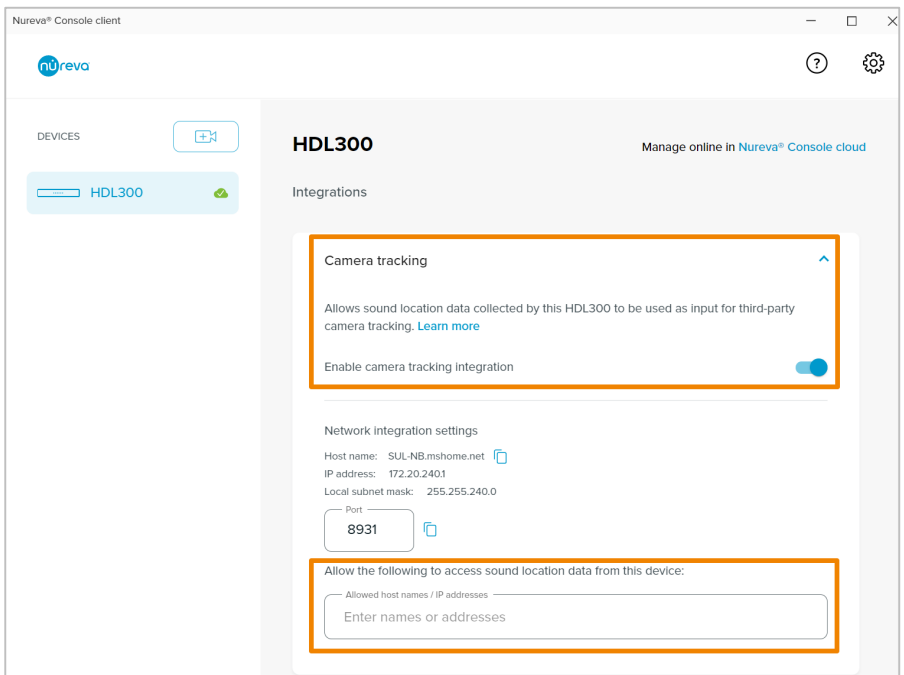

- AVer PTZ Link:

AVer PTZ Link divides HDL microphones' horizontal angles into 8-24 equal parts, which correspond to AVer PTZ Link channel 1-24.

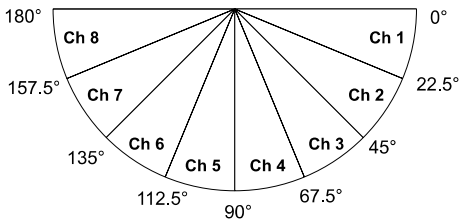

Enter the IP address of the computer running Nureva Console Client as **MIC IP** in AVer PTZ Link.

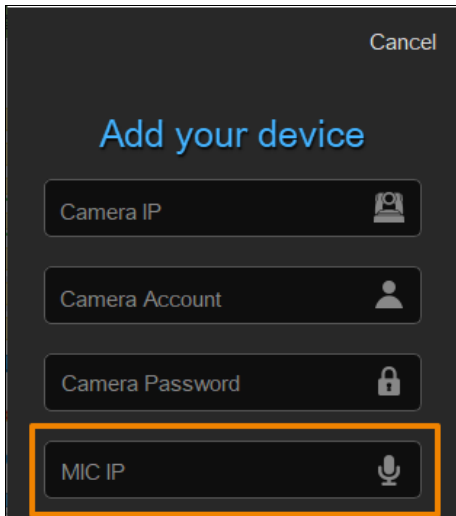

To add a coverage area for HDL410 in AVer PTZ Link:

1. Click **Channel Configure** on the main page.

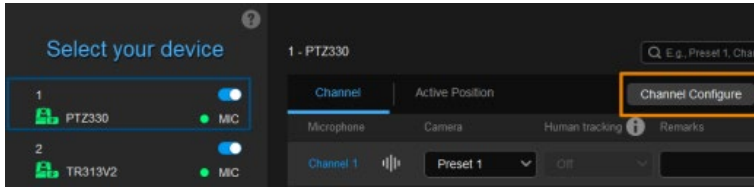

2. Select **Coverage** from the **Pickup Mode** drop-down list.
3. Click **Coverage Map Setting** > Click **Add Coverage**.

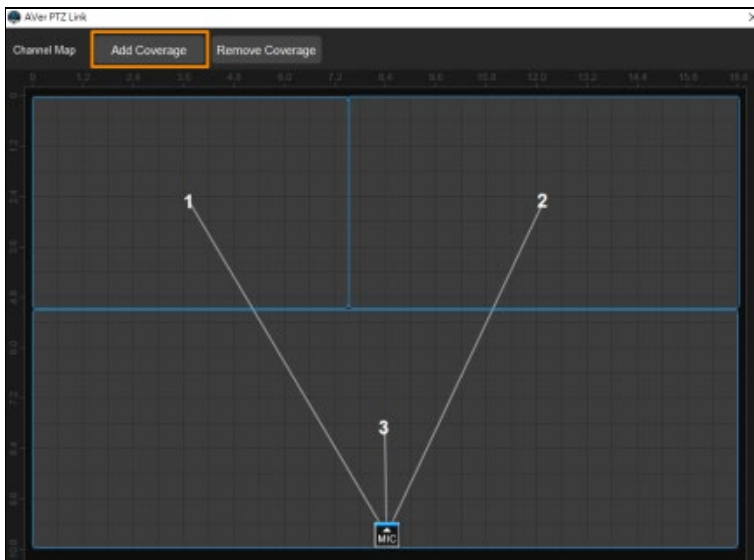
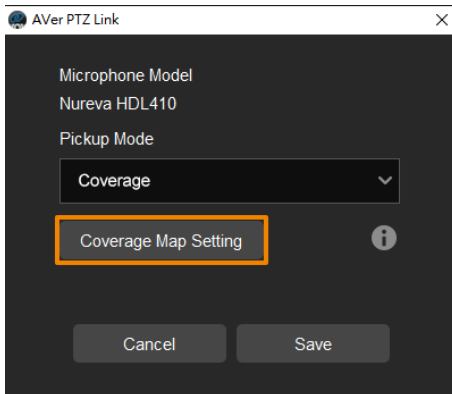

4. Add a coverage area by dragging it.

- You can add up to 8 coverage areas per microphone.
- When coverage areas overlap, the microphone will default to the area with the smaller number.

Sennheiser

TeamConnect Ceiling 2

TeamConnect Ceiling Medium

EW-DX EM 2

EW-DX EM 2 Dante

EW-DX EM 4 Dante

EW-DX TS 3-Pin (and compatible microphones)

EW-DX TS 5-Pin (and compatible microphones)

AVer PTZ Link divides TeamConnect Ceiling 2's and TeamConnect Ceiling Medium's horizontal angles into 8-24 equal parts, which correspond to AVer PTZ Link channel 1-24.

- **TeamConnect Ceiling 2**

An Exclusion Zone set in Sennheiser Control Cockpit also affects the corresponding channel in AVer PTZ Link.

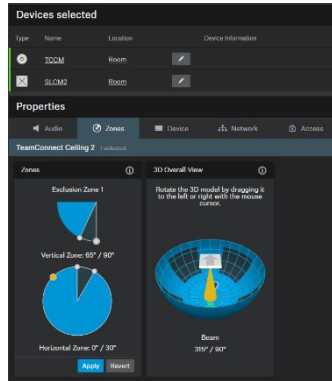
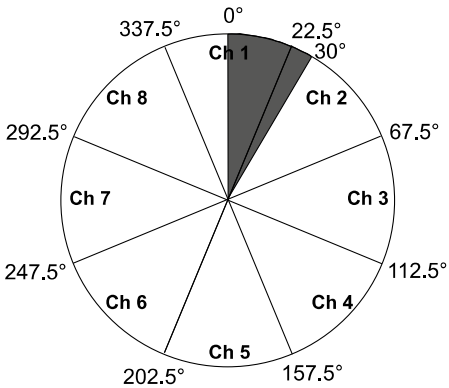

Sennheiser Control Cockpit

- **TeamConnect Ceiling Medium**

The 3rd party media control access for TeamConnect Ceiling Medium is encrypted and protected using username and password. It has to be enabled using Sennheiser Control Cockpit before use.

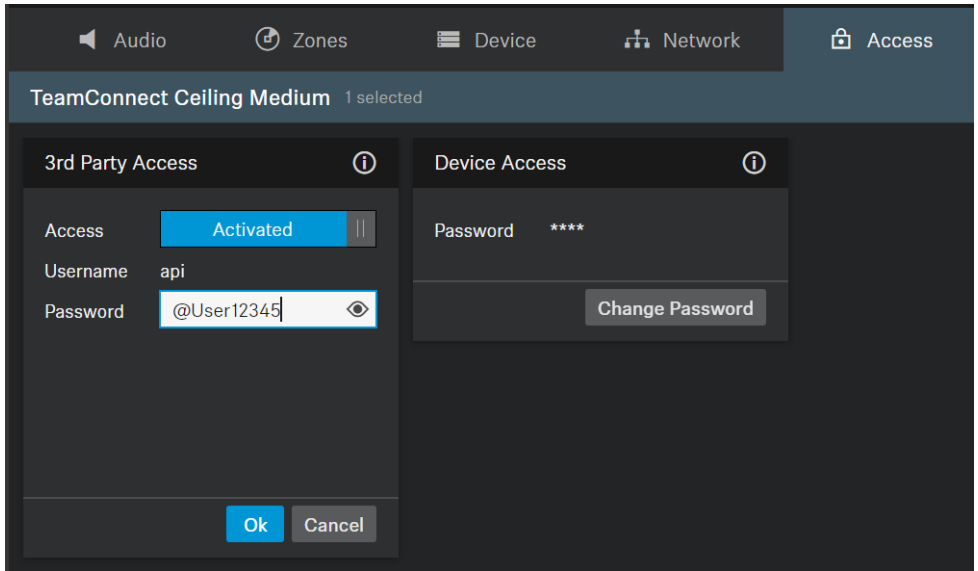

To set a 3rd Party device control password:

1. Open Sennheiser Control Cockpit. Go to the **Access** tab in the device configuration page.
2. Activate the toggle switch.
3. Enter a password.
4. You can use the username "api" and configured password for your API calls.

Note:

- If you deactivate 3rd party access, the previously set password will be deleted.
- Password must be at least 10 characters and no more than 64 characters. Use at least one lowercase letter, one uppercase letter, one number and one special character (!#\$%&()*+,-./:;<=>?@[^_{}~).

- **EW-DX EM-4 Dante and MAT 153 + MEG 14-40**

Each transmitter (MAT 153) will connect to EW-DX 1-4, which correspond to AVer PTZ Link channel 1-4.

You may log in to Sennheiser Control Cockpit to view the status of each transmitter.

For connecting the receiver with the transmitters, please refer to Sennheiser official website:

<https://www.sennheiser-sites.com/responsive-manuals/en/ew-d/ew-d/ew-dx-connecting-synchronizing-em.html>

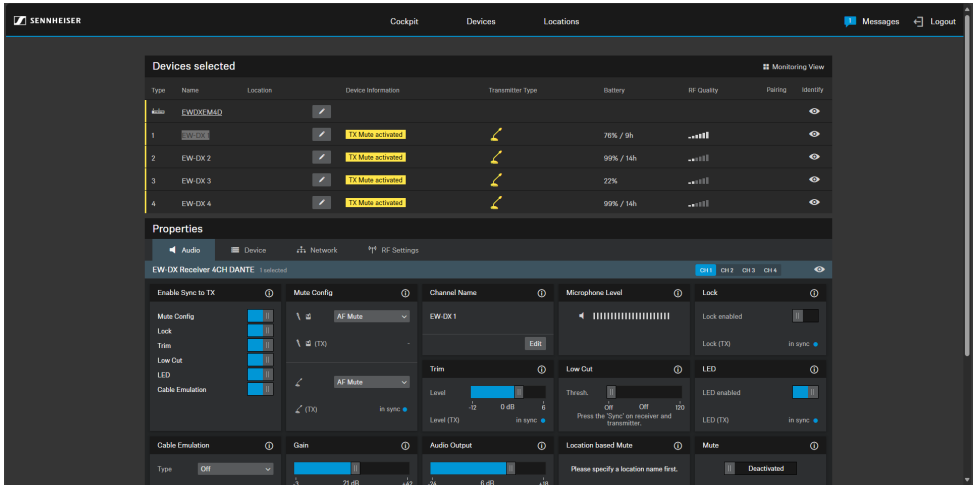

Shure

Shure® IntelliMix® P300 Audio Conferencing Processor

Shure® IntelliMix® Room Audio Processing Software

Shure® MXA310 Table Array Microphone

Shure® MXA710 Linear Array Microphone

Shure® MXA910 Ceiling Array Microphone

Shure® MXA920-S / MXA920-R Ceiling Array Microphone

Shure® Microflex® Complete Wireless (MXCW) System

- **MXA310 Table Array Microphone**

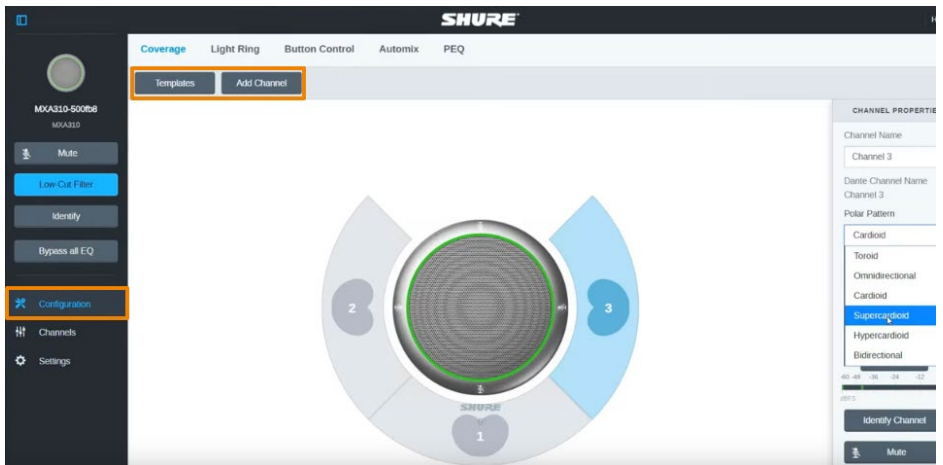

Web Application

1. Open the **Configuration** tab.
2. Select a template from the multi-channel options. Or select **Add Channel** to add more than 1 channel. AVer PTZ Link does not support single channel for the MXA310.

- **MXA910 Ceiling Array Microphone**

The screenshot displays the Shure MXA910 web application interface. At the top, there are control buttons for 'Mute', 'Bypass all EQ', 'EQ contour', 'Coverage', 'Channels', and 'IntelliMix'. Below these are 'Bypass IntelliMix' and 'Revert to defaults' buttons. The main area shows eight channels (Channel 1 to Channel 8) and an 'Automix Out' section. Each channel has a 'Send to mix' button, a gain meter, and a gain control knob. Below the gain controls are buttons for 'AGC', 'Solo', 'Priority', 'Always on', and 'Mute'. The 'Automix Out' section has buttons for 'AEC', 'NR', 'PEQ', 'Comp', 'Delay', and 'Mute'. On the right side, there is a 'Properties' panel with a diagram of the microphone array and a 'Settings' section. The 'Settings' section includes 'Automix mode' set to 'Gating', 'Automix gain meter' (unchecked), 'Maximum open channels' set to '8', and 'Leave last mic on' (unchecked). Below these are 'Off attenuation (dB)' set to '-40' and 'Hold time (ms)' set to '400'. The Shure logo is visible in the bottom right corner.

Web Application

Go to **IntelliMix > Automixer Properties > Deselect Leave last mic on.**

- **MXA920-S / MXA920-R Ceiling Array Microphone**

Note: To integrate with supported AVer camera tracking system via active talker positions, refer to [<Active Position>](#).

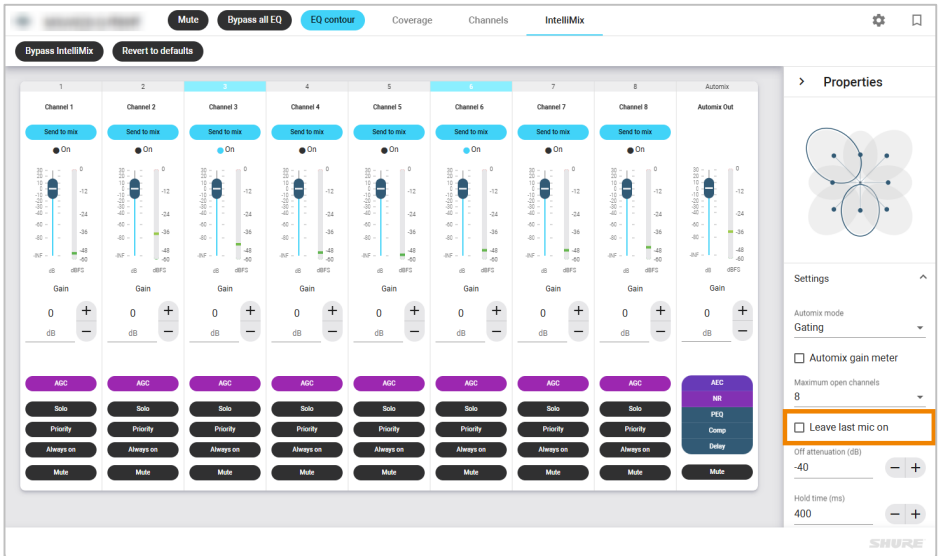

Web Application

To manually position up to 8 lobes:

1. Go to **Settings > General > Turn off Automatic coverage.**

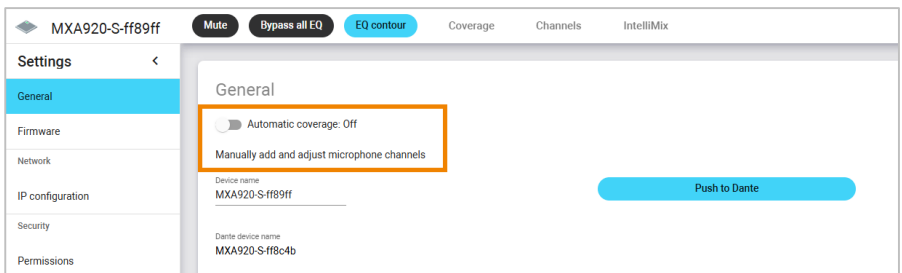

2. Go to **IntelliMix > Automixer Properties > Deselect Leave last mic on.**
3. Click **Channel Configure** in AVer PTZ Link > Select **Lobe** as **Pickup Mode**: The lobes you have positioned in the MXA920's web application. They correspond to AVer PTZ Link channel 1-8.

4. Select **Channel Information**, use the drop-down menu to choose one of the following options :
- Automixer Gate Out** (default; detects all sounds)
 - Talker Position** (is triggered by human voices)

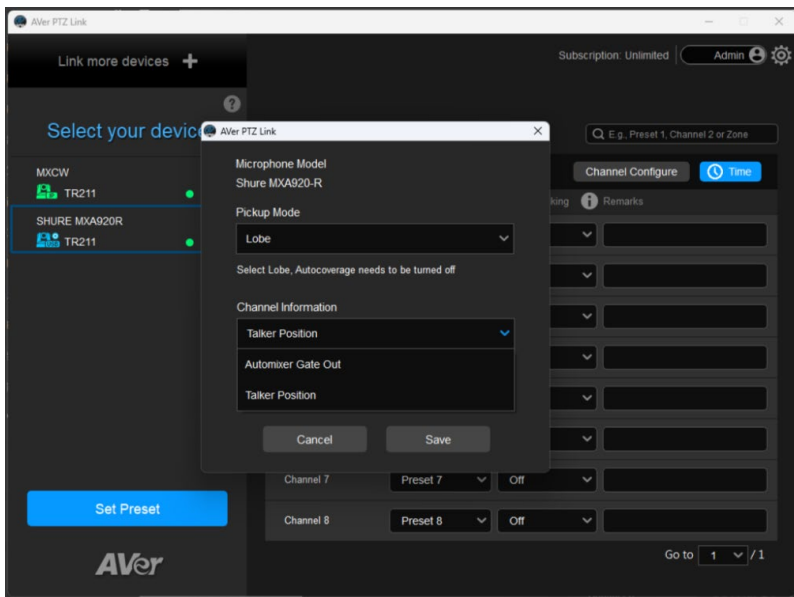

To add a mix of up to 8 dynamic and dedicated coverage areas:

1. Go to **Settings > General > Turn on Automatic coverage.**

The default setting is a 30 by 30 foot (9 by 9 meter) dynamic coverage area.

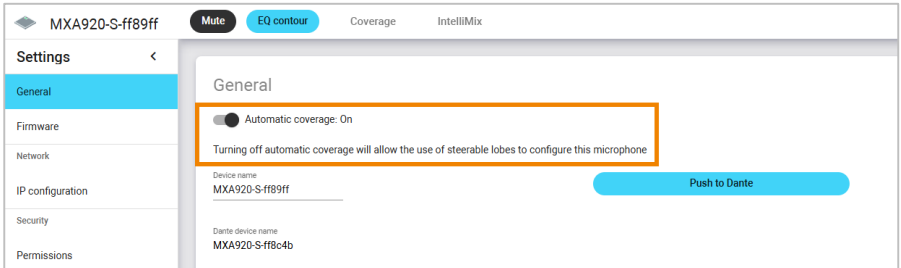

2. To add more coverage areas, go to **Coverage > Add coverage.**
3. Click **Channel Configure** in AVer PTZ Link > select **Coverage** as **Pickup Mode**: The coverage areas you have added in the MXA920's web application. They correspond to AVer PTZ Link channel 1-8.
4. Select **Channel Information**, use the drop-down menu to choose one of the following options :
Automixer Gate Out (default; detects all sounds)
Talker Position (is triggered by human voices)

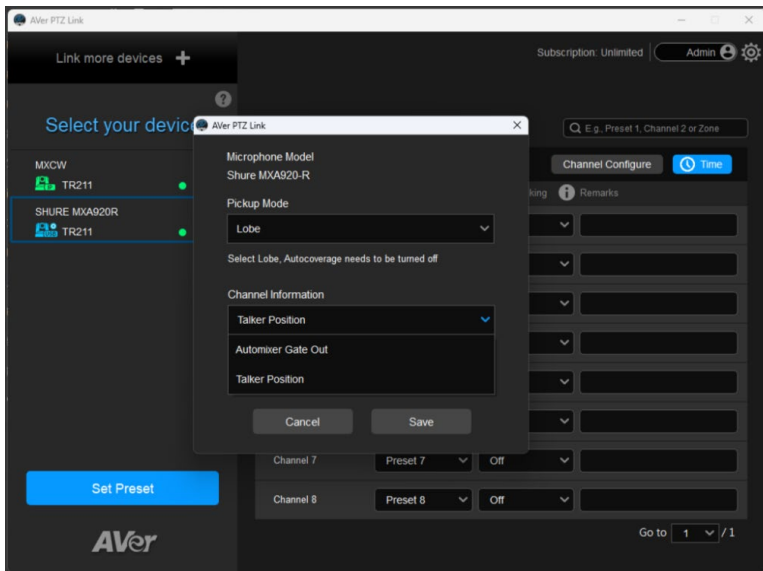

Yamaha

RM-CG Ceiling Array Microphone

RM-TT Tabletop Array Microphone

RM-CR Remote Conference Processor

RM-W Wireless Microphone System

- AVer PTZ Link divides RM-CG's horizontal angles into 8-24 equal parts, which correspond to AVer PTZ Link channel 1-24.

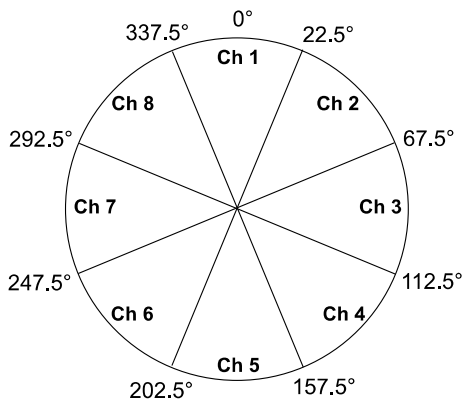

- AVer PTZ Link voice tracking function requires linking more than one RM-TT or RM-W microphones for location data.
- When linking these microphones to the RM-CR Remote Conference Processor, enter the processor's IP address as **MIC IP** in AVer PTZ Link.

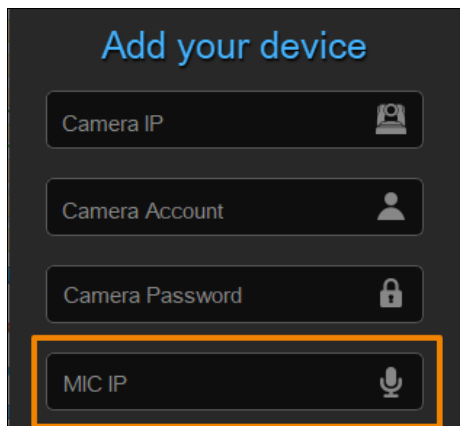





Install AVer PTZ Link

1. Download AVer PTZ Link from AVer Download Center. (<https://www.aver.com/download-center>).
2. Double-click the downloaded .exe file.
3. Follow the instructions to install AVer PTZ Link.



Minimize and Quit AVer PTZ Link

You can minimize AVer PTZ Link to the taskbar or a floating window during a video conference.

To minimize AVer PTZ Link to the taskbar:



1. Go to **Settings**  > **System** > disable **Screen widget**.
2. Click the minimize button  on the top-right corner of the AVer PTZ Link window.
3. To make the minimized AVer PTZ Link active, click the **Show hidden icons** arrow  on the taskbar, right-click the AVer PTZ Link icon , and select **Open AVer PTZ Link**.

To minimize AVer PTZ Link to a floating window:

1. Go to **Settings**  > **System** > enable **Screen widget**.
2. Click the minimize button  on the top-right corner of the AVer PTZ Link window.
3. To make the minimized AVer PTZ Link active, click the maximize button  on the floating window.

To quit AVer PTZ Link:

Click the X button  on the upper-right corner of the AVer PTZ Link window.

Or click the **Show hidden icons** arrow  on the taskbar, right-click the AVer PTZ Link icon  and select **Exit**.

Connections

It is recommended to connect all devices to the same local area network (LAN). Or UDP port-52381 and TCP port-2202 must be available between devices.

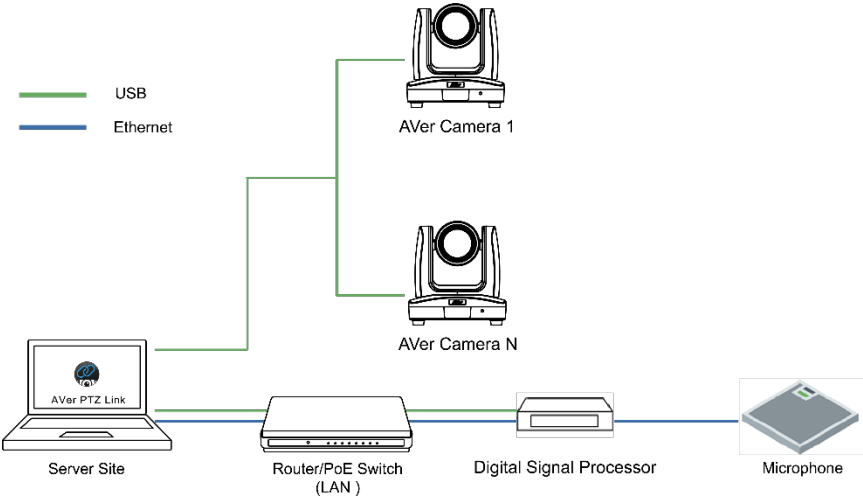
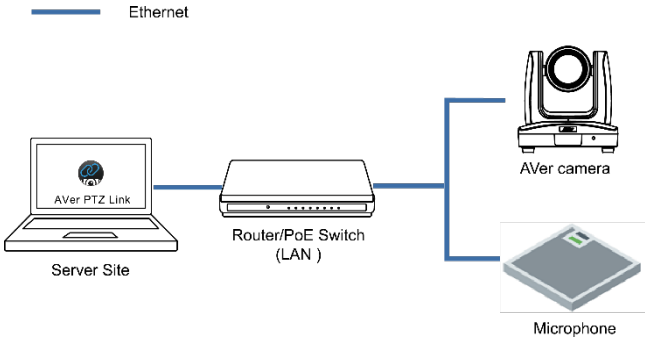

Get Started

User Interface

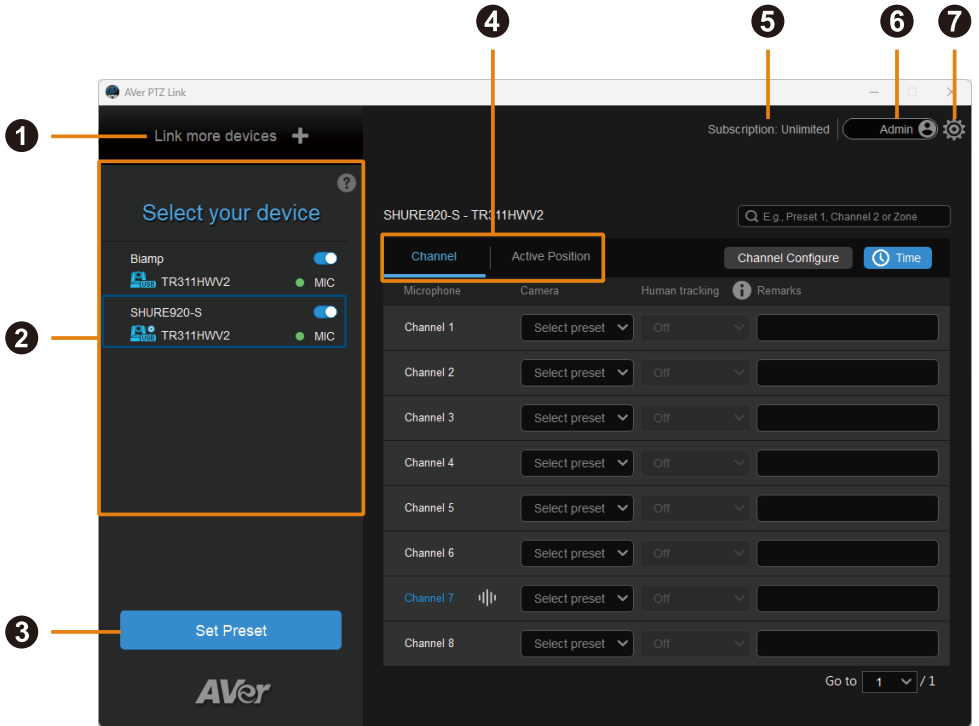

1. Link more devices +

Add cameras and microphones.

2. Device Group List

Displays added camera and microphone groups.

3. Set Preset

4. Voice Tracking Modes

5. Subscription or Free Trial Status

6. Account Type

An admin has full access of functions.

To switch to an **Admin** account, click the toggle and enter the admin account password. To switch back to a **User** account, exit and restart AVer PTZ Link.





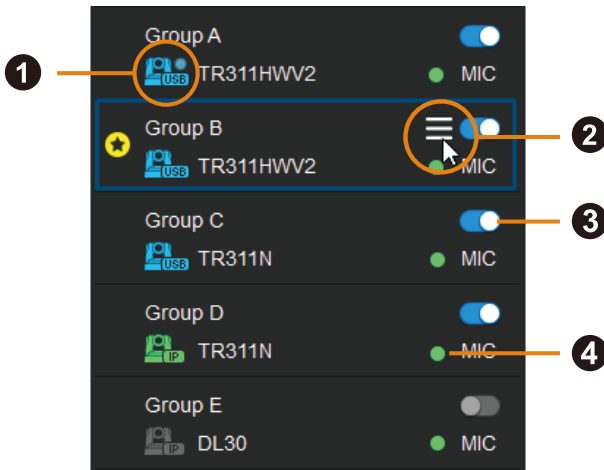

7. System Settings

Device Group List



1. Camera Status

Click the **question mark** icon  for descriptions.

Icon	Status
	Device online.
	Device offline
	Virtualcam is sent to the third party program
	Virtualcam is enabled
	Incorrect account or password
	Inactivated

2. Hamburger Menu



Hover your cursor over a device group to see the hamburger menu.

- Edit: Edit the device group.
- Delete: Delete the device group.
- Priority: Assign a priority group .

3. Toggle

Enable or disable a device group.

4. Microphone Status

 Green	Online
 Gray	Offline

Add Devices

Cancel

Add your device

Admin

Connect Camera via IP

Camera IP

Camera Account

Camera Password

Audio-Technica

MIC IP

Select your MIC channels

Device Name

Link

AVer

Add up to 5 camera + microphone groups (free) or 25 camera + microphone groups (premium).

1. Click **Link more devices +** on the top-left corner of the interface.
2. Select **Connect Camera via IP** or **Connect Camera via USB** from the drop-down list.

Note:

- Make sure you have turned off sleep mode on the connected USB camera.
- The resolution of connected USB camera for video conference must be 720p or higher.

3. Enter the camera and microphone information.

Items	Description
Camera IP	Enter the IP address of the camera. You can add both online and offline cameras.
Camera Account	Enter the account of the camera.
Camera Password	Enter the password of the camera.
MIC Brand	Select the microphone brand.
MIC IP	Enter the IP address of the microphone.
MIC Channels	Select the number of microphone channels.
Device Name	Enter a name for the device group in fewer than 20 characters.

4. Click **Link** to add the camera and microphone group to the device group list.

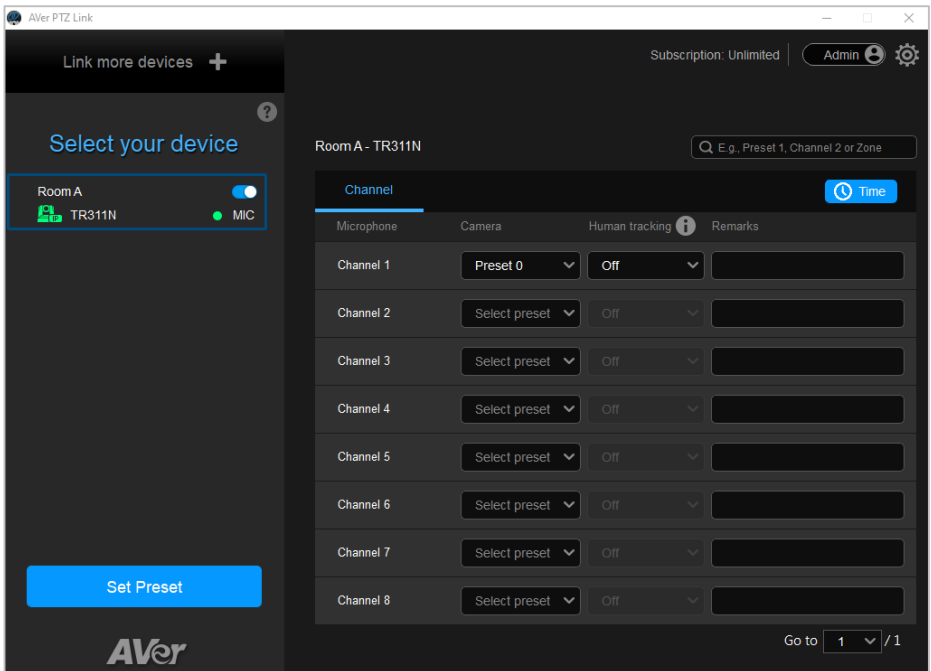

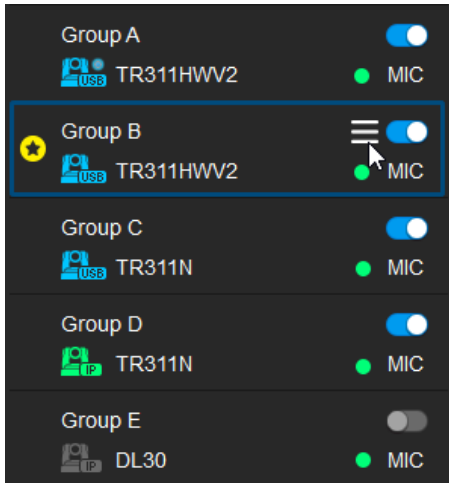

5. You can also assign a priority Group if multiple device groups share the same camera (Refer to [Assign a Priority Group](#)).

Assign a Priority Group



You can assign a priority group for the camera to go to when:

- Multiple groups share a camera.
- Microphone detects no sound (default preset 0).
- Multiple Speakers Mode activates (default preset 0).
- Microphone detects far end speakers (Sennheiser microphones only, default preset 0)

1. Hover the cursor over a group, then click the **hamburger** icon .
2. Select **Priority**. The **star** icon  will indicate a priority group.
3. To cancel priority, deselect **Priority**.

Set a Preset

IP Cameras

1. Click to select an IP camera on the device group list.

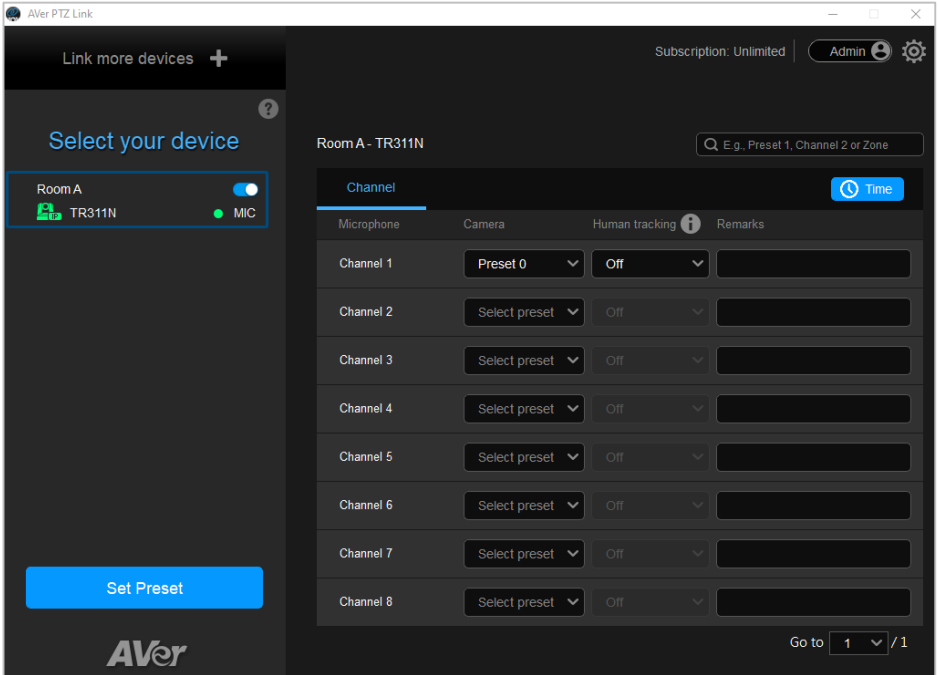

2. Click **Set Preset**. The camera web interface will open in your browser.
3. On the web interface, go to **Live View > Preset**.
4. Position the camera using pan, tilt and zoom controls, enter a preset number (0–255) in the **Save Preset** field, then click **Save**.

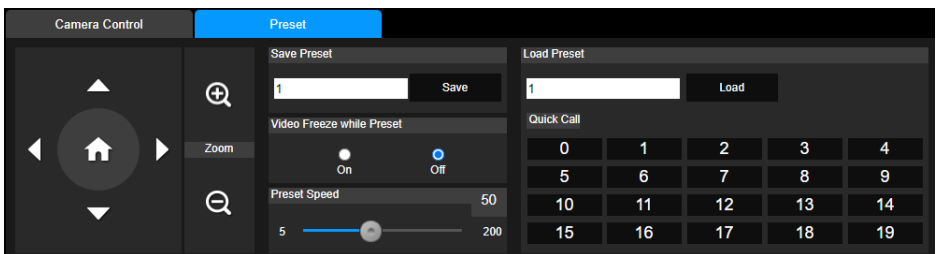

USB Cameras

1. Click to select a USB camera on the device group list.

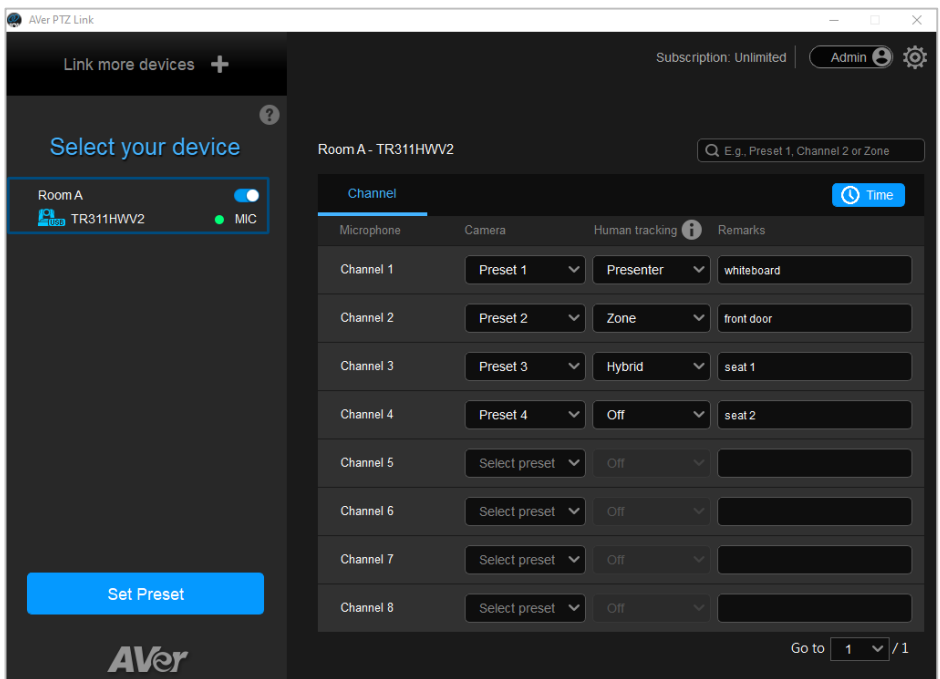

2. Click **Set Preset**. A live view window will appear.
3. Select the USB camera from the drop-down list on the control panel.



4. Click to select a preset number you want to save, position the camera using pan tilt and zoom controls, then click **Save**.

You may return to your defined position at any time by clicking the preset number.

Set up Voice Tracking

Channel Mode

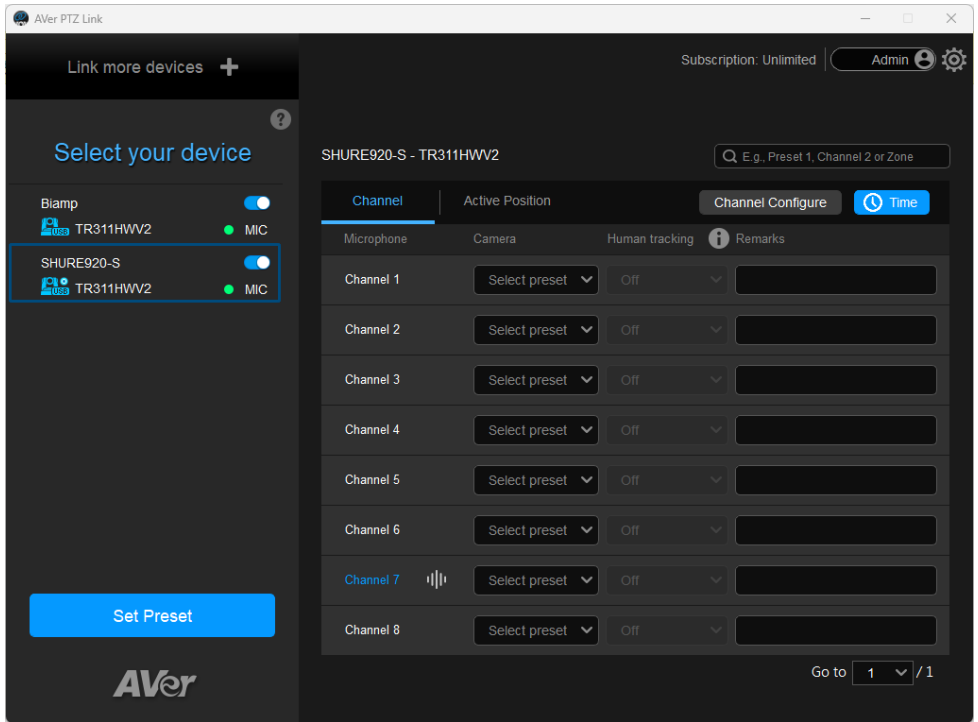

Pairing microphone channels with presets turns AVer cameras into voice tracking cameras. When the camera detects sound from a microphone channel, the camera will go to the paired preset.

An **audio signal** icon  will identify which channels detect voice, while a blue highlight will indicate an active channel.

1. Make sure you have defined the required presets (Refer to [<Set a Preset>](#)) and configured microphones (Refer to [<Supported Microphones>](#)).
2. Click to select a device group. A blue frame will indicate that it is selected.
3. Go to **Channel**, then select a preset from the drop-down list for each microphone channel.

4. You can also select a **Human tracking** mode to follow the presenter in real time. Make sure you have configured tracking modes on the camera web interface.

Example:



Microphone detects voice



Camera goes to preset



Presenter Tracking

Note: Tracking modes may vary depending on your AVer camera model. Make sure you have configured tracking modes on the camera web interface.

5. Add **Remarks** to identify the location.

Note: Remarks can also appear as text overlays on the live view for USB cameras. Go to **System Settings > Camera Setting > turn on Display channel remarks on virtual camera.**

6. Click the **Time** button  to set a delay before the camera goes to a preset.

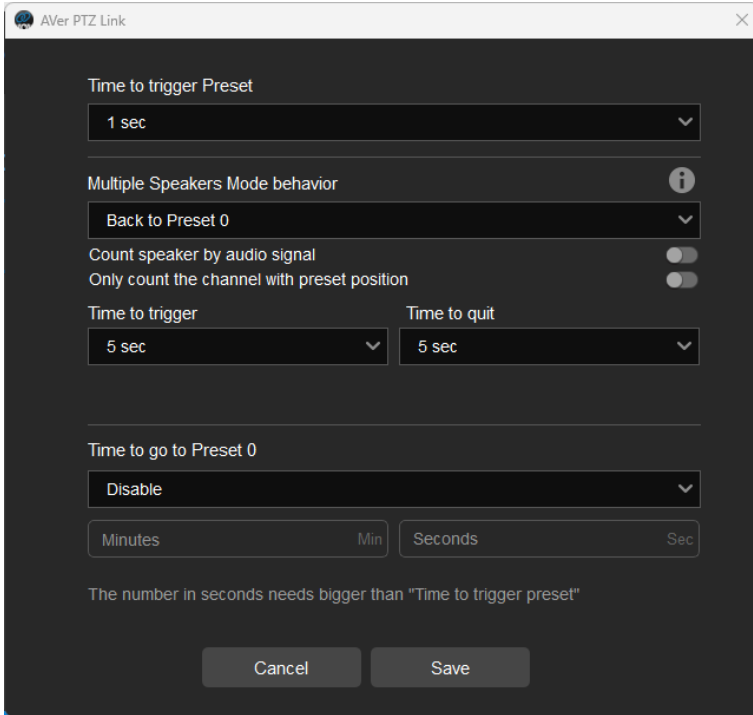

Item	Description
Time to trigger Preset	Set a delay before the camera goes to a preset.
Multiple Speakers Mode behavior	<p>When multiple voices are detected, Multiple Speakers Mode activates and the camera goes to preset 0 of the last camera to minimize disorienting movements. Refer to Multiple Speakers Mode Conditions for details.</p> <ul style="list-style-type: none"> • Enable Multiple Speakers Mode by selecting Back to Preset 0. • You can also assign a different preset for the camera to go to. Refer to Assign a Priority Group.
Time to go to Preset 0	<p>Set a delay before the camera goes to preset 0 of the last camera when the microphone detects no sound.</p> <ul style="list-style-type: none"> • You can also assign a different preset for the camera to go to. Refer to Assign a Priority Group. • The duration of Time to go to Preset 0 must be longer than Time to trigger Preset.

<p>Far end speakers trigger Preset 0 (Sennheiser microphones only)</p>	<p>If the microphone detects voice from the far end of the room, such as during a video conference, the camera will go to preset 0 of the last camera.</p> <ul style="list-style-type: none"> You can also assign a different preset for the camera to go to. Refer to <Assign a Priority Group.>
--	--

Multiple Speakers Mode Conditions

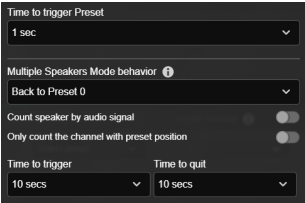
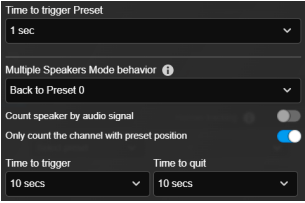
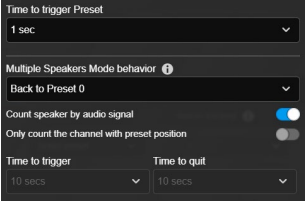
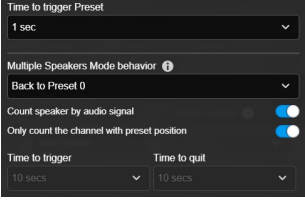
Conditions	Enter Mode	Leave Mode	
<p>Active channel (default)</p>	<p>3 active channels are active in a set time (Time to trigger).</p>	<p>Fewer than 3 active channels are active in a set time (Time to quit).</p>	
<p>Active channel with preset</p>	<p>3 active channels with presets are active in a set time (Time to trigger).</p>	<p>Fewer than 3 active channels with presets are active in a set time (Time to quit).</p>	
<p>Audio signal channel Suitable for gooseneck discussion units</p>	<p>2 or more audio signal channels are active at the same time.</p>	<p>1 or no audio signal channel is active at the same time.</p>	
<p>Audio signal channel with preset Suitable for gooseneck discussion units</p>	<p>2 or more audio signal channels with presets are active at the same time.</p>	<p>1 or no audio signal channel with preset is active at the same time.</p>	

Note: The durations of **Time to trigger** and **Time to quit** must each be at least 3 times that of **Time to trigger preset**.

Active Position (Premium)

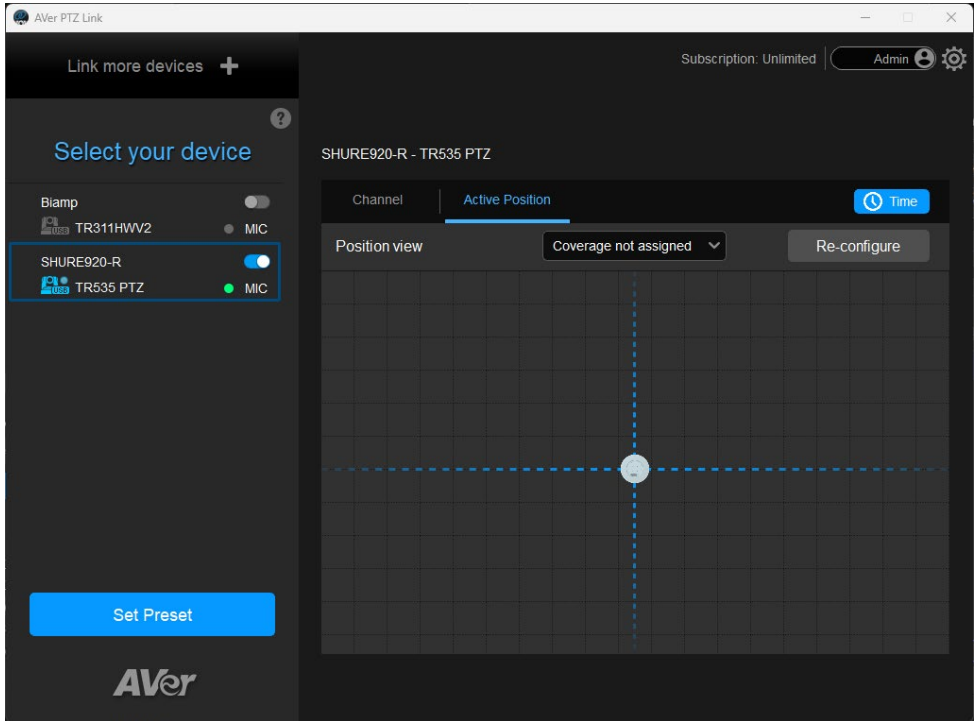

Active Position reports active talker positions from supported microphones in the form of X, Y, Z coordinates to deliver enhanced camera tracking.

Supported Devices

USB-connected [supported AVer cameras](#)

Shure® MXA920-S / MXA920-R / MXA901 Ceiling Array Microphone

Square Microphone Calibration

1. Make sure the camera has been paired with a microphone.
2. Click to select a device group. A blue frame will indicate that it is selected.

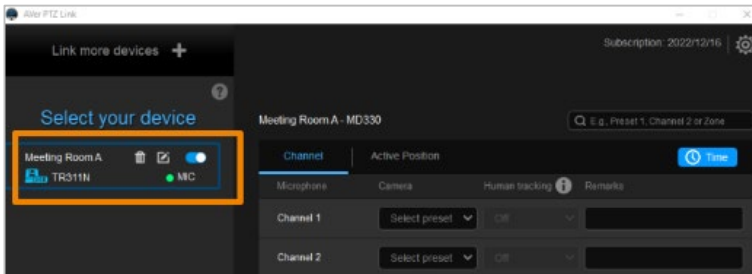

3. Click the **Active Position** tab and follow the setup wizard. Click the question mark  in the top-right corner for instructions.

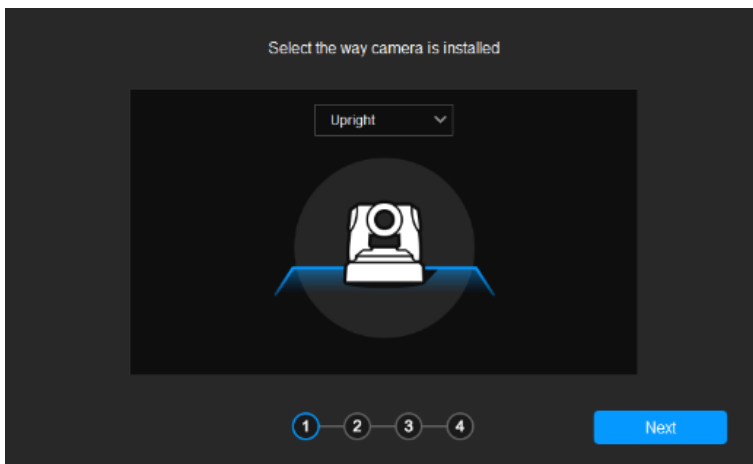

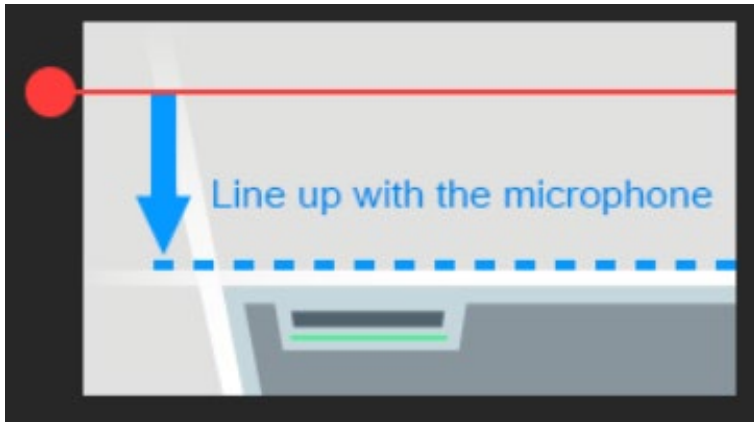

Dragging the red dot to align the red line to the top or bottom edge of the microphone.

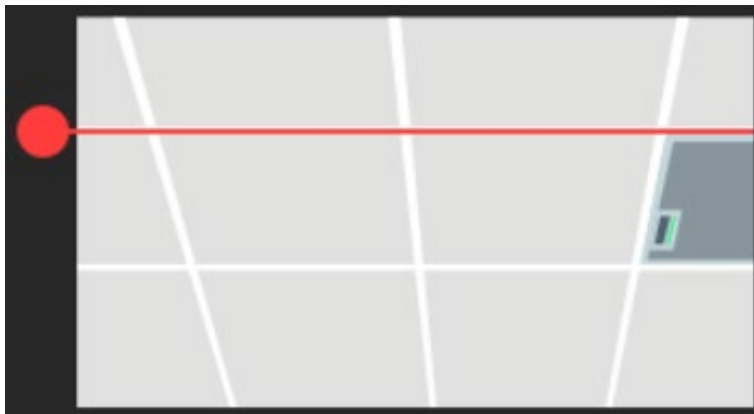

The microphone doesn't need to be in the center of the live view, as long as the red line is aligned to the edge. Adjust the camera angle using pan, tilt and zoom controls, if the microphone appears at a slight angle.

Locate the first 3 corners of the microphone

Set the red coordinates in a clockwise direction accordingly. Make sure each coordinate aims at the top left, top right, and bottom right corner of the microphone.

You may control the camera position using pan, tilt, zoom on the panel.

[Note] The first coordinate of the microphone must be positioned at the top left corner regardless of where the microphone logo is.

Next

Starting from the top left, locate 3 microphone corners in a clockwise direction with a red cross.

Locate the corners of the microphone

PTZ Control

Preview

1

Back

1 2 3 4

Set

Reset

Next

Click **Set**. The saved location will appear in the thumbnail.

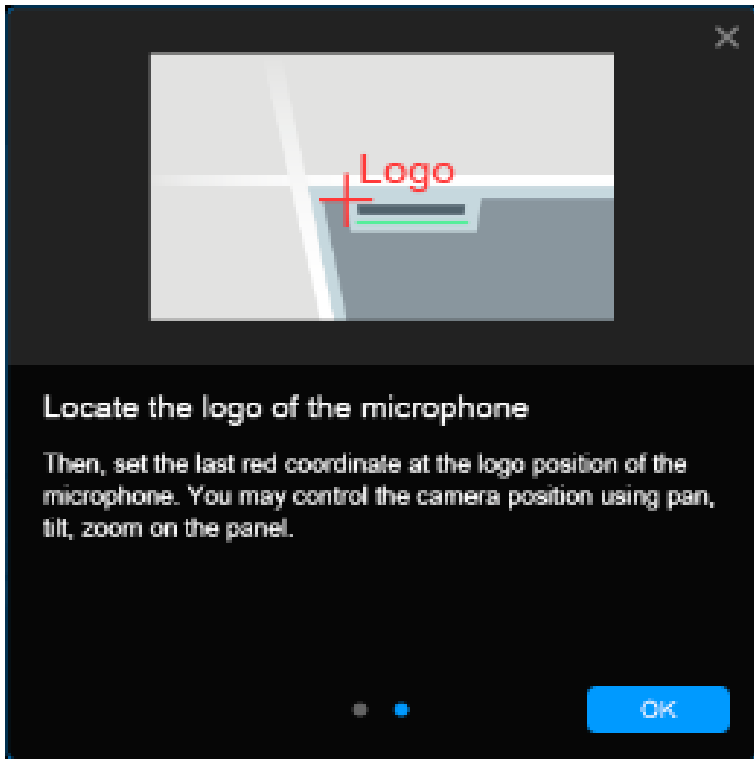

Finally, locate the logo on the microphone to indicate its orientation. Depending on the microphone orientation, the logo corner may be the same as one of the 3 corners.

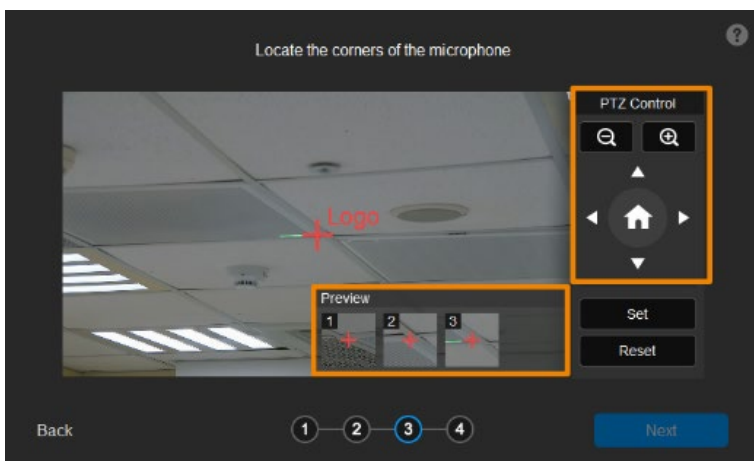

Click **Next** after locating 3 corners and the logo. Or click **Reset** to relocate all of them.

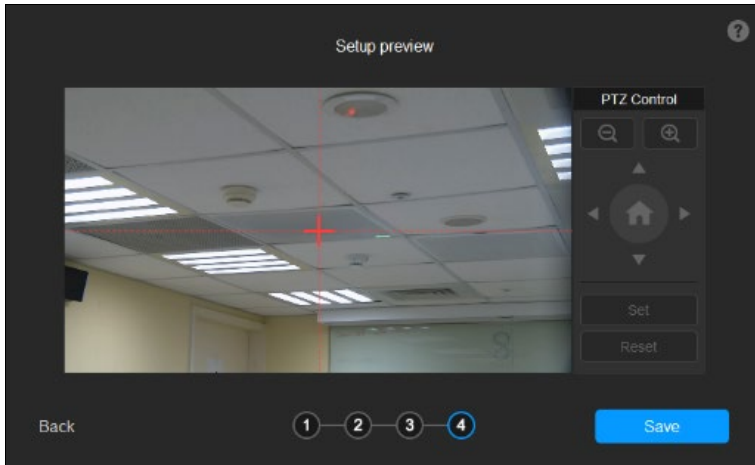

Make sure the red cross appears in the center of the microphone, and click **Save**. Or click **Back** to reconfigure.

Round Microphone Calibration

1. Make sure the camera has been paired with a microphone.
2. Click to select a device group. A blue frame will indicate that it is selected.

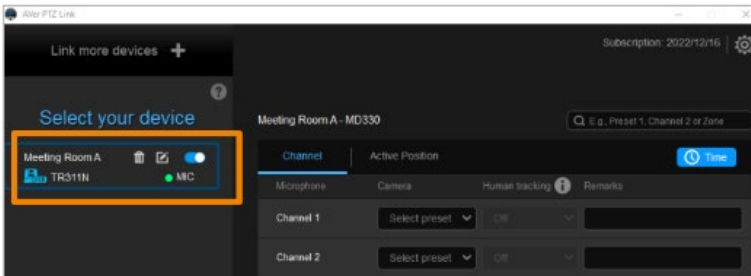

3. Click the **Active Position** tab and follow the setup wizard.
Click the question mark  in the top-right corner for instructions.

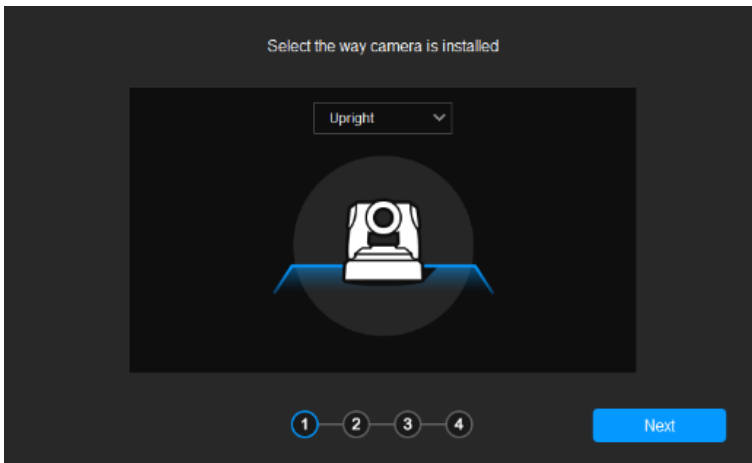

Locate the microphone center

Set the red coordinate at the microphone center.

Drag the red lines to check if the red coordinate is at the microphone center.

Make sure the red lines cover the inner circular edge of microphone.

[Note] Adjust the camera zoom to see the microphone and LED clearly.

[Note] Make the red lines cover the inner circular edge of microphone rather than the outer edge of microphone.

OK

Dragging the red dot to align the red lines to the top and left edge of the inner diameter so that the red cross appears at the center.

AVer PTZ Link

Locate the top point of the microphone

Set the red coordinate at the top point of the inner circular edge of microphone.

[Note] Locate the top point on the inner circular edge of microphone rather than the outer edge of microphone.

Back

Next

Reset

PTZ Control

Locate the top point of the inner diameter with the red cross.

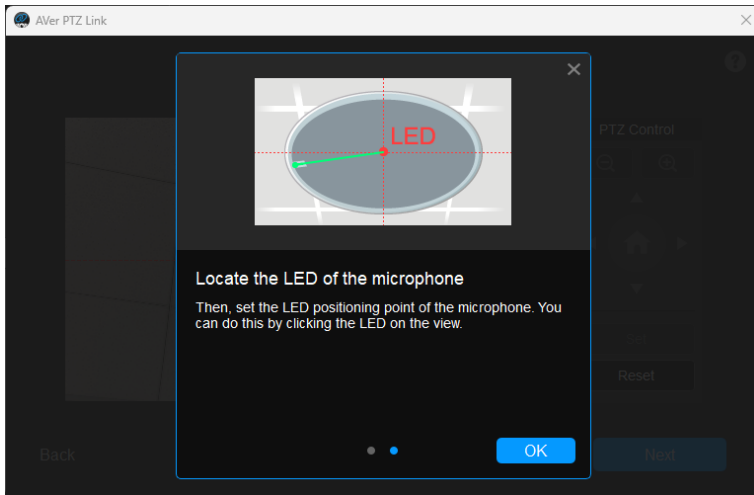

Click to mark the position of the LED.

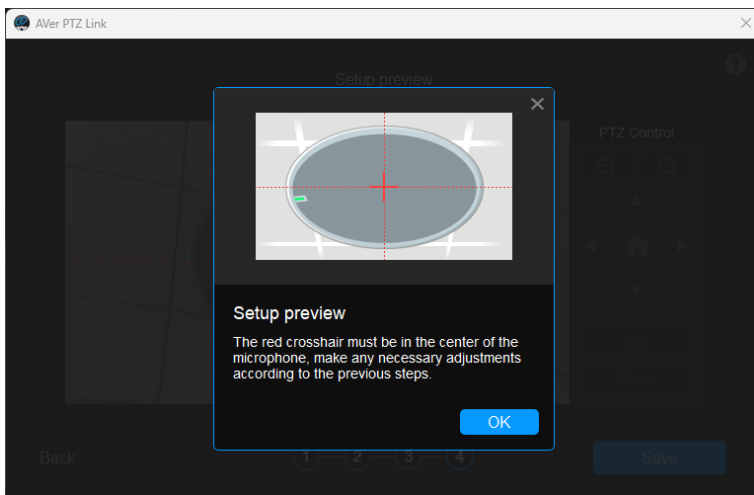

Make sure the red cross appears in the center of the microphone, and click **Save**. Or click **Back** to reconfigure.

Add a Coverage Area

1. On the MXA920 web application, go to **Settings > General > Automatic coverage**.
2. Turn on **Automatic coverage** to add a mix of up to 8 dynamic and dedicated coverage areas,. The default setting is a 30 by 30 foot (9 by 9 meter) dynamic coverage area.

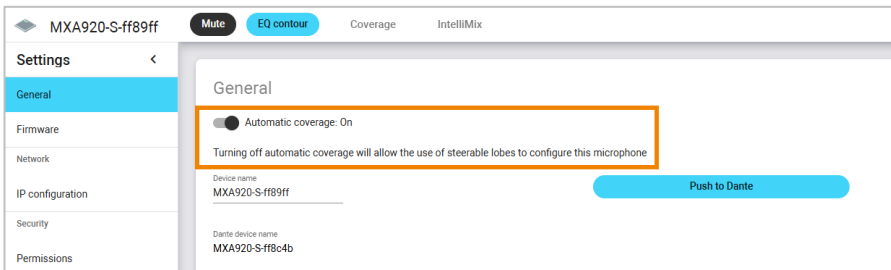

3. To add more coverage areas, go to **Coverage > Add coverage**.
4. Go to **Active Position** in AVer PTZ Link > select **Coverage not assigned** to use all coverage areas.
Or select a coverage area that you have added in the web application from the drop-down list. Talker positions outside of the selected coverage area won't be picked up by AVer PTZ Link.

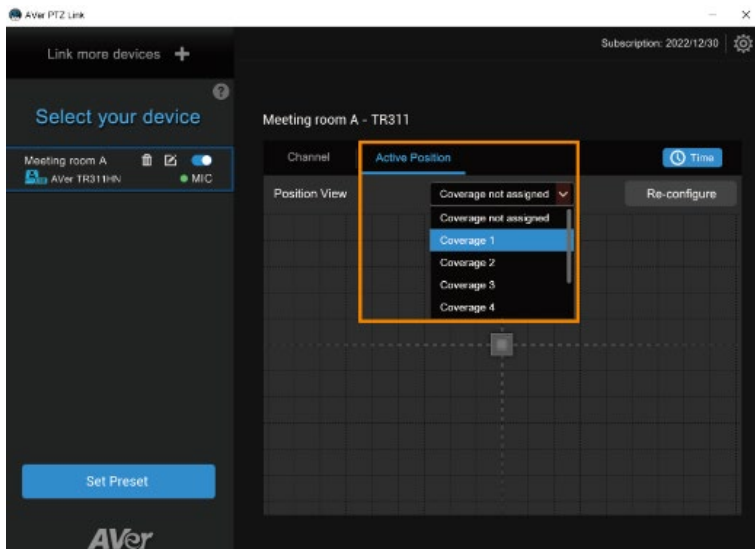

- To change coverage areas, click **Re-configure**.

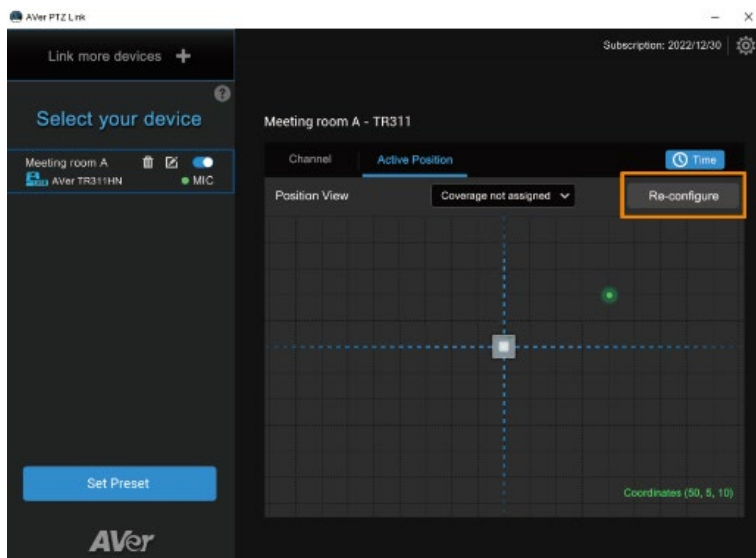



AVer PTZ Link System Settings

Click the **System settings** icon  on the upper right corner of the main page to configure system settings.

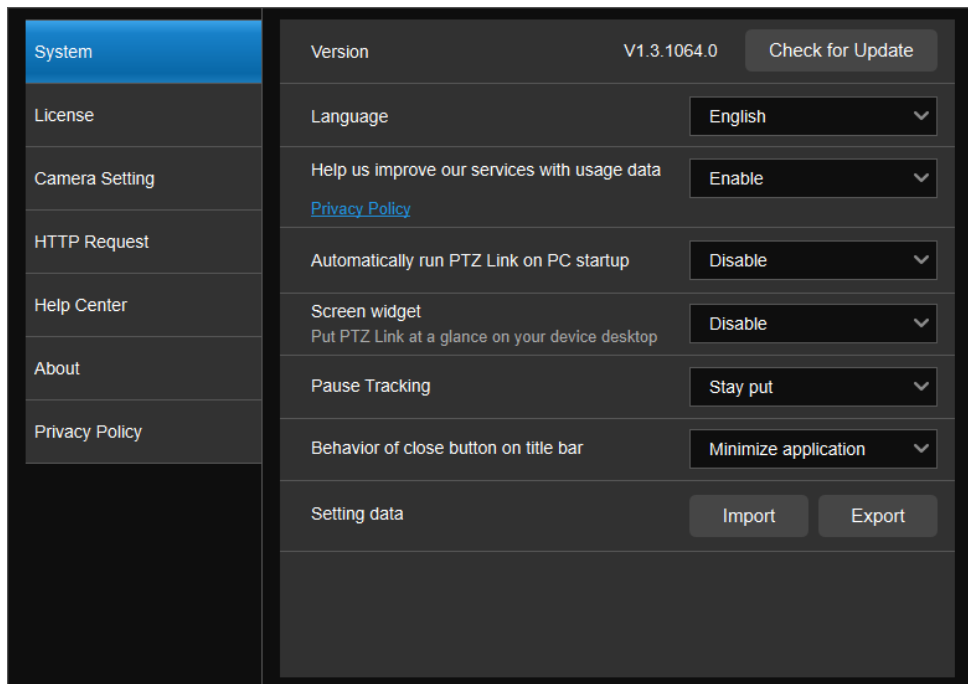
System



System	Version	V1.3.1064.0	Check for Update
License	Language	English	▼
Camera Setting	Help us improve our services with usage data	Enable	▼
HTTP Request	Privacy Policy		
Help Center	Automatically run PTZ Link on PC startup	Disable	▼
About	Screen widget	Disable	▼
Privacy Policy	Put PTZ Link at a glance on your device desktop		
	Pause Tracking	Stay put	▼
	Behavior of close button on title bar	Minimize application	▼
	Setting data	Import	Export

Item	Description
Version	View software version and check for update.
Language	Select a preferred language.
Help us improve our services with usage data	Opt-in to or opt-out of providing usage data.
Automatically run AVer PTZ Link on PC startup	Add AVer PTZ Link to run at startup.
Screen widget	<ul style="list-style-type: none">• Enable or disable a floating window when minimizing AVer PTZ Link.<ul style="list-style-type: none">-  Disable all devices on the device group list. Or set the camera's pause position in Pause Tracking.-  Resume all devices on the device group list.

	<ul style="list-style-type: none"> -  Maximize AVer PTZ Link. • The screen widget also works in Zoom.
Pause tracking	Select if a camera stays at the last position or return to Preset 0 when tracking is paused.
Behavior of close button on title bar	Choose to minimize or quit AVer PTZ Link when closing the window.
Setting data	Export or import device settings such as camera-microphone pairs, presets, and channels when changing computers. This data doesn't include license information.

License

Enter your license key to upgrade to the premium version.

- One license key can only be activated on one computer.
- To transfer your license key to another computer, deactivate the license key from your old computer and activate it on your new computer.

To start a 60-day free trial:

1. Go to the **License** tab, then click **Start Free Trial**.

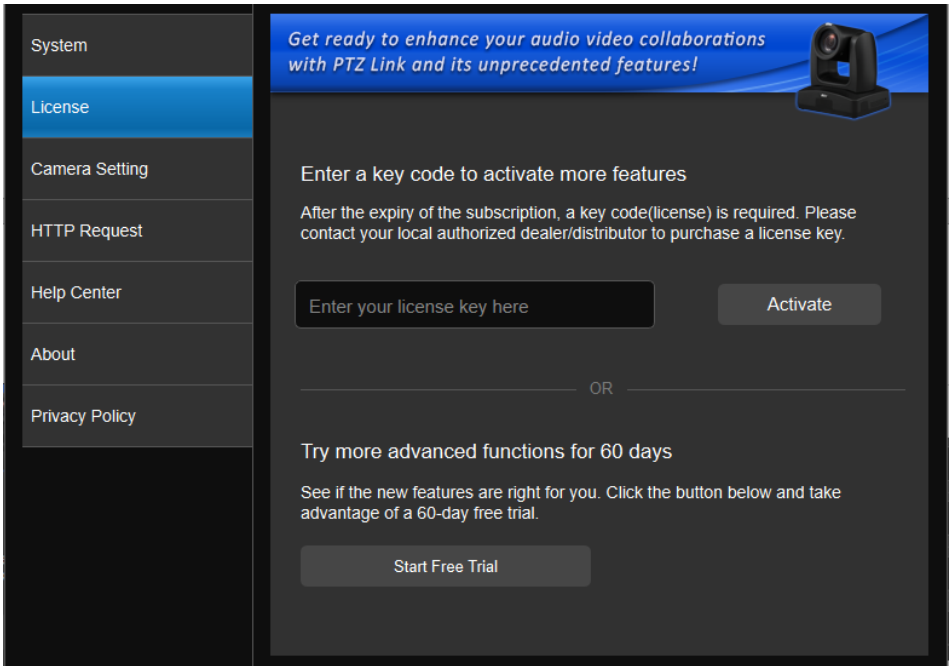

2. Subscribe for the latest updates on AVer PTZ Link.

3. Your free trial starts immediately. Check the free trial expiration date on the **License** tab or on the upper-right corner of the main page.

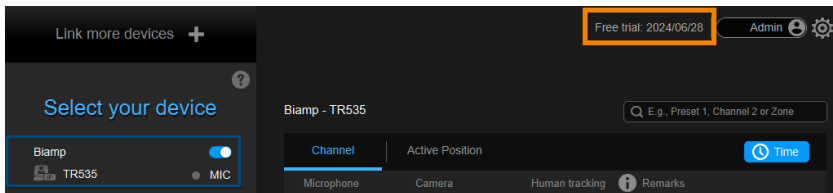
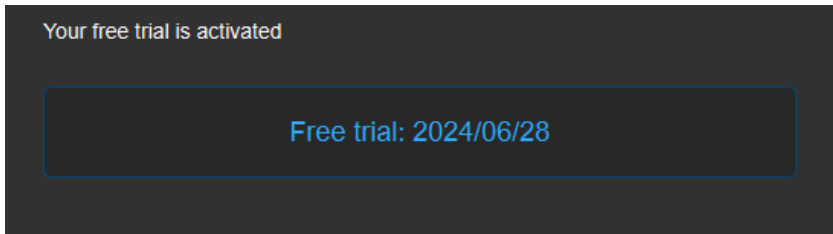

To activate the license key:

1. Go to the **License** tab, enter your license key, and click **Activate**.

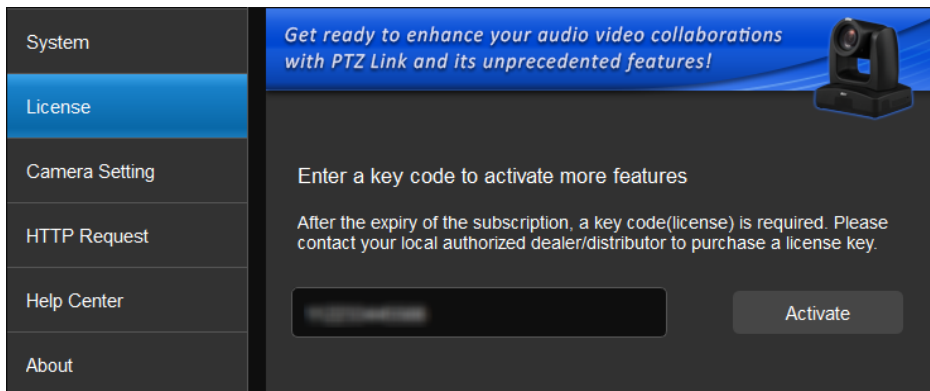

2. Follow the on-screen instructions to complete the activation.

Note: If you upgrade to the Premium version during your free trial period, you will immediately lose access to the remainder of your free trial. You cannot reactivate this trial. Click **No, start Free Trial first** to use the free trial first.

To deactivate the license key:

1. Go to the **License** tab, then click **Deactivate**.

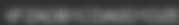
System	Current Plan Status	Premium 
License	Date activated	2022/09/12
Camera Setting	Expiration date	Unlimited
HTTP Request	Your key code	
Help Center	Deactivate your license	<input type="button" value="Deactivate"/>
About	Once this license key is deactivated on this PC, you can utilize the key on another PC.	
Privacy Policy	Contact Information	<input type="button" value="Update Contact Info"/>
	jo.kuo@aver.com	
	AVer	

2. Follow the on-screen instructions to complete the deactivation.

Camera Setting

Note: Camera Setting applies to virtual cameras (USB cameras) only.

System	Virtual camera layout	Single
License	Display channel remarks on virtual camera	Off
Camera Setting	Mirror channel remarks	Off
HTTP Request	Switching camera delay time	Off
Help Center	Auto-center on speaker	On

Item	Description
Virtual camera layout	Select a live view layout for USB cameras: <ul style="list-style-type: none">• Single: When multiple USB camera groups detect sound at the same time, the layout will be a single live view showing one active speaker.• Side-by-side (Windows only): When multiple USB camera groups detect sound at the same time, the layout will be a side-by-side live view showing two active speakers.
Display channel remarks on virtual camera	Turn on to display remarks as text overlays on the live view. Add remarks to identify the location of each channel.
Mirror channel remarks	Turn on to mirror remarks on the live view.
Switching camera delay time	Set a delay time before switching to another camera's live view for a seamless transition.
Auto-center on speaker (Windows Only)	Turn on to allow the camera to automatically adjust the PTZ lens after a sound-activated preset is triggered, keeping the person centered in the frame. (This feature is available only when using IP-based control.)

HTTP Request

HTTP request allows third-party integration and lets you quickly perform various tasks to your groups on the device group list.

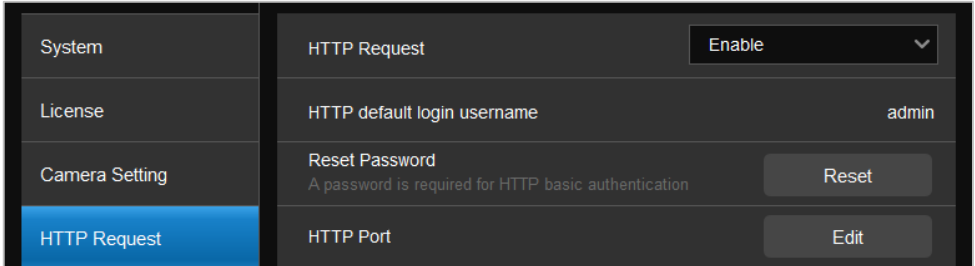

1. On the main page, go to **Settings > HTTP Request**.
2. Set up the HTTP request configuration:
 - Enable **HTTP Request** from the drop-down list.
 - Click **Reset** to set up a password.
 - Click **Edit** to enter a port number.
3. Execute any of the following HTTP requests:

Account	HTTP default login username admin .
Password	The password you set up in step 2.
IP Address	IP address of your computer.
Port	The port number you set up in step 2.

Function	Request
Pause all groups	http://[account]:[password]@[IP Address]:[port]/request=pause
Resume all groups	http://[account]:[password]@[IP Address]:[port]/request=resume
Query pause status of all groups	http://[account]:[password]@[IP Address]:[port]/request=queryPauseStatus
Disable all groups	http://[account]:[password]@[IP Address]:[port]/request=disableAll
Enable all groups	http://[account]:[password]@[IP Address]:[port]/request=enableAll
Disable a specified group	http://[account]:[password]@[IP Address]:[port]/request=disable&group=[Group ID]
Enable a specified group	http://[account]:[password]@[IP Address]:[port]/request=enable&group=[Group ID]
Query status of a specified group	http://[account]:[password]@[IP Address]:[port]/request=queryStatus&group=[Group ID]

Help Center

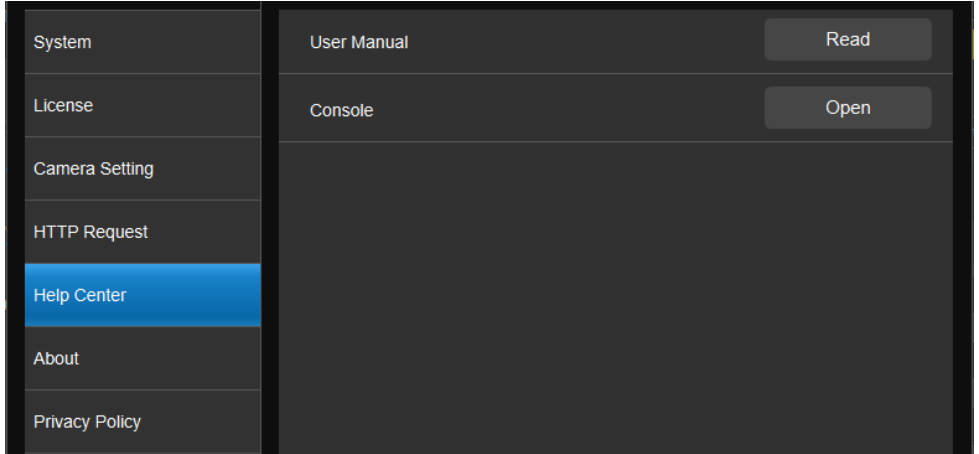

Item	Description
User manual	Click Read to open the user manual in your browser.
Console	Open a debug console window showing microphone status. You can clear, pause or save the result.

About

View the terms and conditions.

Privacy Policy

View the privacy policy.

Troubleshoot

Which third-party microphone systems are supported?

Refer to <[Supported Microphones](#)>.

Pause voice tracking

- Mute the microphone on the respective software or web interface to stop reporting audio data to AVer PTZ Link. Or press the physical mute button, if any.
- Turn on AVer PTZ Link screen widget. Click the pause button on the screen widget to disable all groups on the device group list. Click the resume button on the screen widget to resume all groups.

How does Shure microphones' Mute function work with AVer PTZ Link?

- If a channel is muted on the Shure web interface, the corresponding channel of AVer PTZ Link will not detect sound.



Camera is too sensitive and flickering between presets.

- Set a longer delay for [Time to Trigger Preset](#).
- If your camera is shared among several camera and microphone groups, [assign a priority group](#).

Sennheiser TeamConnect Ceiling 2 picks up sound from all over the room.

When conversations go back and forth, assign a **Priority Zone** in Sennheiser Control Cockpit to minimize flicking between presets.

For details on the Priority Zone, please visit: https://www.sennheiser-sites.com/responsive-manuals/SCC/EN/index.html#page/SCC_EN/SCC_04_EN.5.3.html#ww1106250.

