

# M11-8MV

**Instruction Manual** | 安裝指南

取扱説明書 | **Bedienungsanleitung**

**Manuel d'instructions** | **Manual de instrucciones**

**Manuale di istruzioni**

English.....	1
繁體中文.....	28
日本語.....	55
Deutsch.....	83
Français.....	110
Español.....	138
Italiano.....	166

## Package Contents

The items below are included with this product. If any item is missing, contact the dealer from whom you purchased this product.

M11-8MV Unit

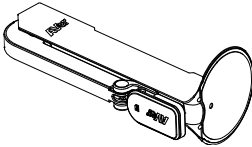

USB Cable

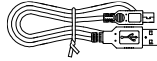

QR Code Card



Warranty Card\*



\* Only for Europe, Japan, and Taiwan

## Optional Accessories

Carrying Bag



Anti-glare Sheet

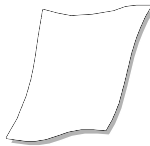



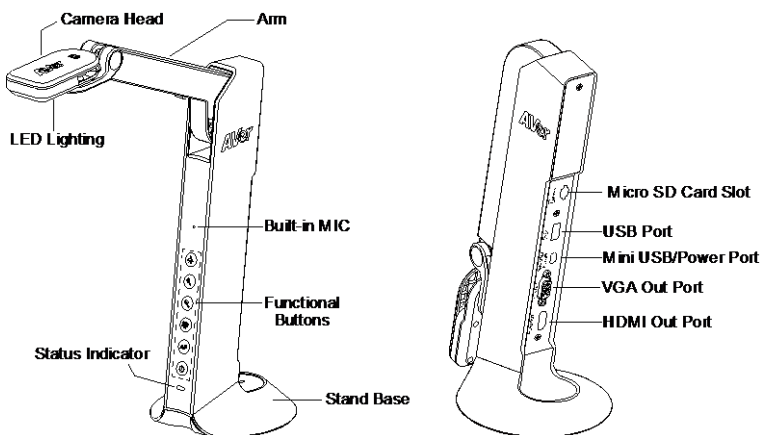



# Overview







# Function Buttons

## Control Panel





Button	Function
	<ul style="list-style-type: none"> <li>■ Lamp on/off</li> <li>■ Press and hold 3 seconds to call out OSD menu.</li> </ul>
	Zoom in
	Zoom out
	<ul style="list-style-type: none"> <li>■ Rotate 0/180°</li> <li>■ Press and hold 3 seconds to freeze the screen. To un-freeze, press and hold 3 seconds again.</li> </ul>
	<ul style="list-style-type: none"> <li>■ Auto focus</li> <li>■ Press and hold 3 seconds to start recording.</li> </ul> <p>To stop recording, press and hold  3 seconds again.</p>
	Power on/off

## OSD Mode

Button	Function
	<ul style="list-style-type: none"><li>■ Back to last menu level page</li><li>■ Exit from OSD menu</li></ul>
	Up (selection item)
	Down (selection item)
	Selection enter

## Compound Key

Press keys to operate the compound key function.

Button	Function
 + 	Back to factory default settings
 + 	Capture image

**[Note]** For **Recording** and **Capture**, please change to “**Power Supply Only**” mode.

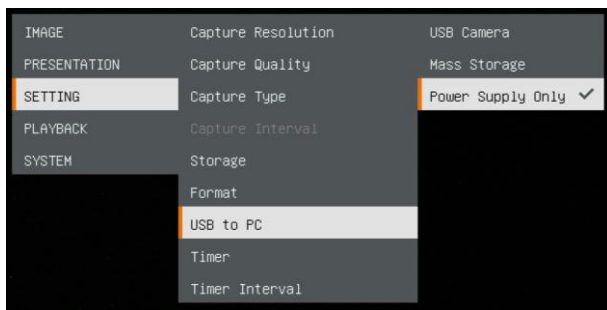

## LED Indicator

Power 	<b>Solid green:</b> Power on <b>Solid red:</b> Standby <b>Flashing red:</b> The camera is in start-up process.
---	--

# Device Connection

## Power Connection to Wall Outlet

1

Plug in power and turn on M11-8MV.

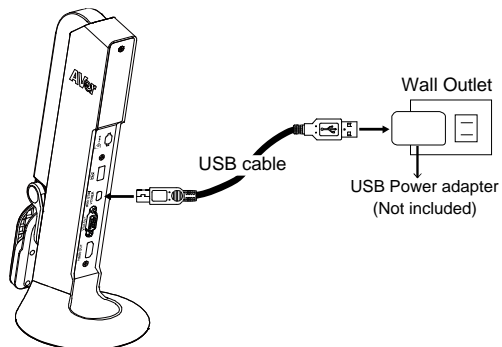

### [Note]

- Use the USB cable included in the package to connect to mini USB/Power port of M11-8MV with USB power adapter (not included) to wall outlet.
- User needs to purchase a 5V/1A USB power adapter (not included) to connect the USB cable to wall outlet.
- When the camera is start-up, the power indicator is in flashing red.

## Power Connection to PC/Laptop

1 Connect to USB port of PC/laptop for power supply.

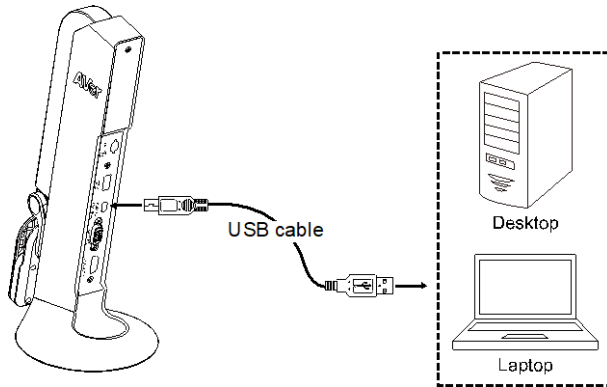

### [Note]

- Use the USB cable included in the package to connect to mini USB/ Power port of M11-8MV with laptop/PC.
- When the camera is start-up, the power indicator is in flashing red.
- USB power requirement of M11-8MV is USB 5V/1A.
- For Storage, Format, Capture, Recording and Playback functions, please change to **"Power Supply Only"** mode

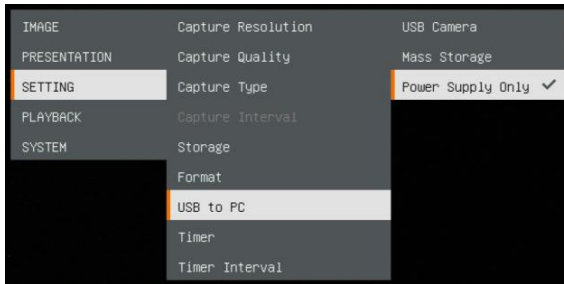

## HDMI Connection

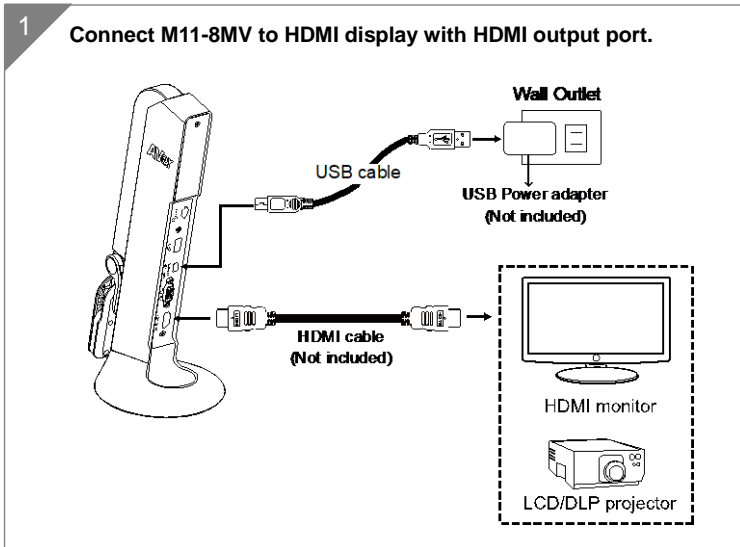

## VGA Connection

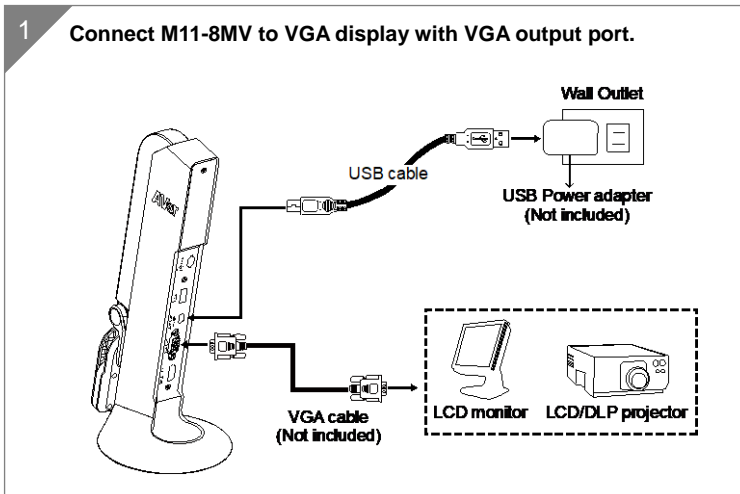

## USB Connection

1

Connect USB flash drive to USB port to save the capture and recording file.

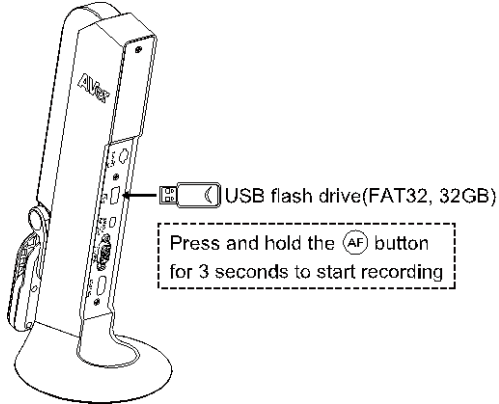

[Note] The supported USB flash drive maximum is 32G (FAT32).

## Insert a Micro SD Card

1

Insert the card to micro SD card slot.

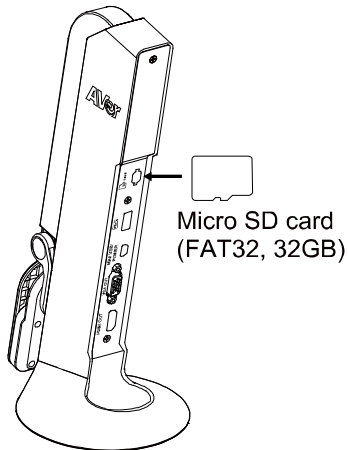

[Note]

- Micro SD card can store capture images and recording files.
- The supported micro SD card capacity maximum is 32G (FAT32).

# Operate the Camera with AVerTouch

1

Connect the camera to PC/laptop and Install the AVerTouch application.

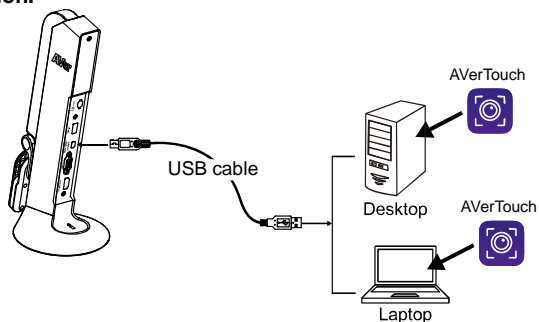

[Note]

- Download AVerTouch application at:  
<https://www.aver.com/download-center/>
- Please set the camera to USB mode. Go to **OSD menu** > **SETTING** > **USB to PC** > **USB Camera**.

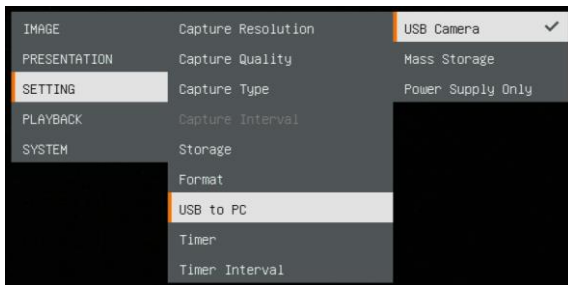

2

Open AVerTouch application, click  to connect the camera.

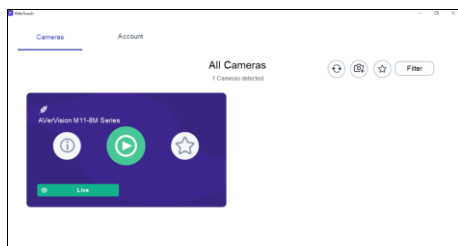

# Presentation Mode (Live)

[Note] Before using annotation feature or PIP/PBP function of presentation mode, set the camera to Power Supply Only mode first. Go to **OSD menu > SETTING > USB to PC > Power Supply Only**.

## Annotation

In single image live (preview) mode, user can use the annotation feature to overlay straight line or freeform line on the captured image with the USB mouse connected to the USB port of M11-8MV.

1. Connect the mouse to USB port of M11-8MV.

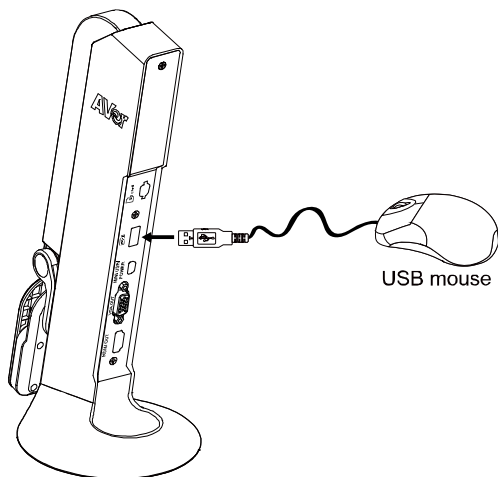

2. Go to **OSD menu > PRESENTATION > Annotation**.

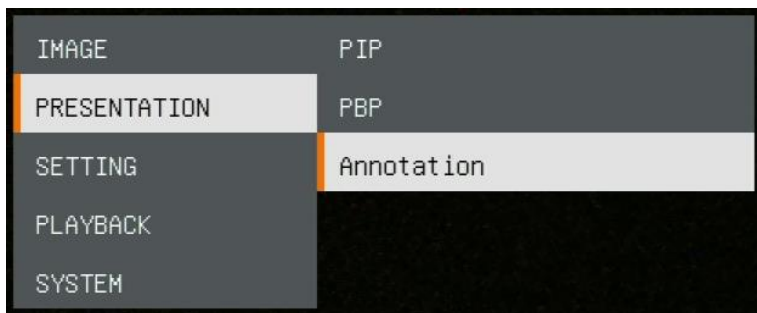



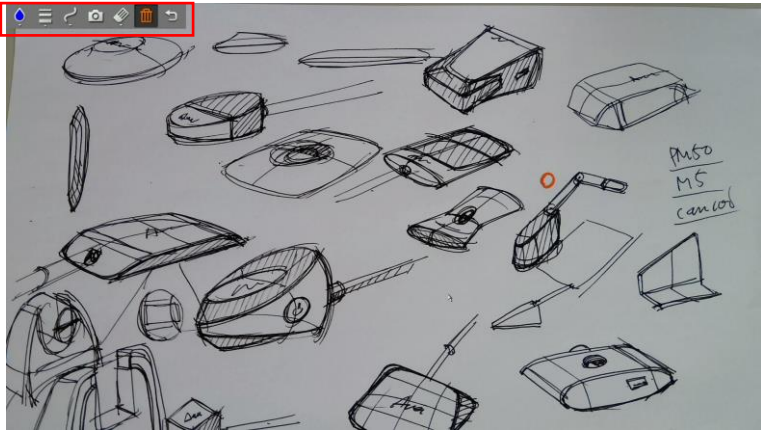







3. In live screen, right-click mouse to call out annotation bar.



**Annotation bar description**



Button	Function
 Color Palette	Select the line color. 
 Line Thickness	Select the thickness of the line. 
 Line	Select a straight line, freehand or sharp to draw. 
 Capture	Capture the image with the annotation and save it as a new file.
 Eraser	Select to erase any part of the annotation that it comes in contact with or delete all annotation.
 Delete	Clear all annotation on the screen.
 Back	Exit annotation bar.

## PIP Function

Select the thumbnail playback screen location and show the thumbnail playback screen at the corner of the screen to recall the captured image from the SD card.





1. In camera mode, press and hold  button for 3 seconds to call out OSD menu.
2. Use  and  buttons to move to **PRESENTATION > PIP**. Press  to confirm the selection.
3. Select the display location of thumbnail playback screen – **Upper Left**, **Upper Right**, **Lower Left**, or **Lower Right**. Press  to confirm the selection.





IMAGE	PIP	Upper Left
PRESENTATION	PBP	Upper Right
SETTING	Annotation	Lower Left
PLAYBACK		Lower Right
SYSTEM		

4. The PIP display screen shows as following.

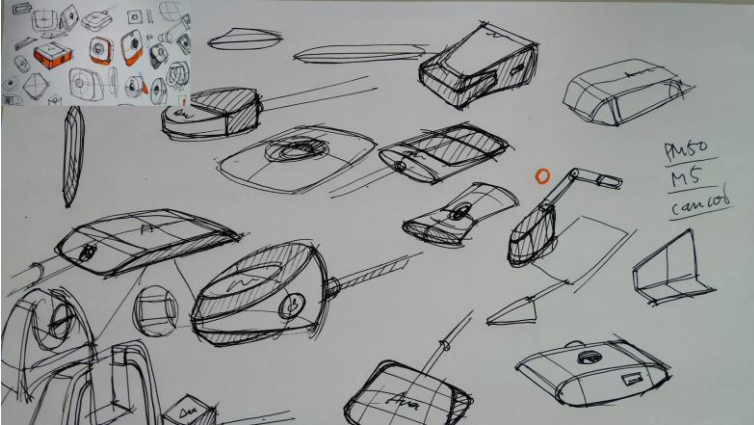



## PBP Function

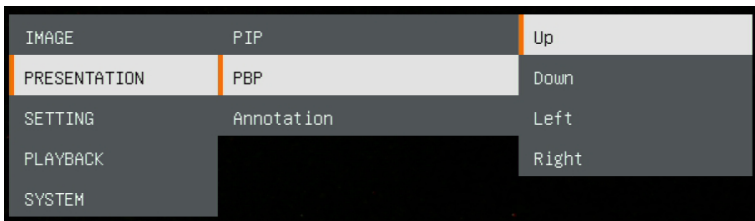

Select the captured image location and show the capture image on the screen to recall the captured image from the SD card.

1. In camera mode, press and hold  button for 3 seconds to call out OSD menu.
2. Use  and  buttons to move to **PRESENTATION > PBP**. Press  to confirm the selection.
3. Select the display location of thumbnail playback screen – **Upper Left, Upper Right, Lower Left, or Lower Right**. Press  to confirm the selection.

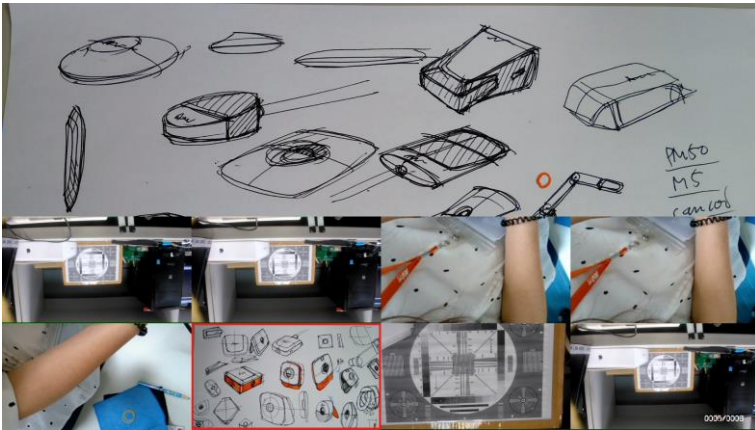

4. Use  and  buttons to select the captured image from the list



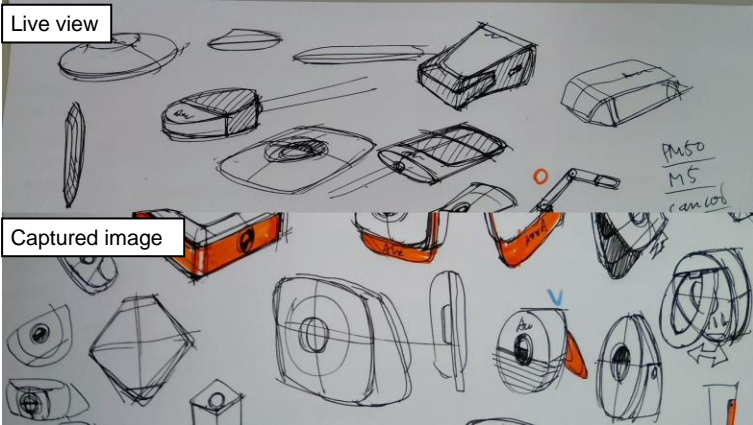

5. The PBP display screen shows as following (PBP is down location). Use  and  buttons to move the captured image up and down to view.











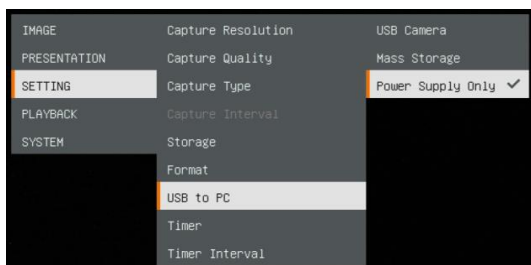



# Playback Mode

View the capture images and recording files.

## Switch to Playback Mode





1. In camera mode, press and hold  button for 3 seconds to call out OSD menu.
2. Use  and  buttons to move to **SETTING > USB to PC > Power Supply Only**.

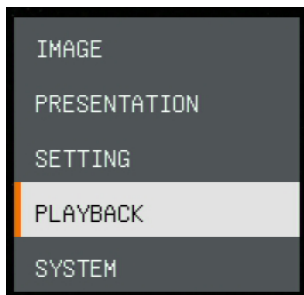















3. Use ,  and  buttons to move to **PLAYBACK** selection.
4. Then, press  to confirm the selection and switch to playback mode.
5. In Playback mode, use  +  and  +  buttons to select image or video to view manually. To play a video, press  button to start playback.  
To pause playback, press  button again. Press  to stop playback.



## OSD Menu Buttons

Button	Function
	Back to last menu level page
	Up (selection item)
	Down (selection item)
	Selection enter

## Playback Menu Buttons

Button	Function
 + 	<ul style="list-style-type: none"> <li>Image / video selection</li> </ul>
 + 	<ul style="list-style-type: none"> <li> + : Fast forward while playback video</li> </ul>
 + 	<ul style="list-style-type: none"> <li> + : Fast rewind while playback video</li> </ul>
	Zoom in image
	Zoom out image
	<ul style="list-style-type: none"> <li>Play video</li> <li>Press and hold to pause while video is playback</li> </ul>
	Stop play video

## Slide Show

To automatically play all capture images and recorded videos; but videos only display files and will not play video contents.



## Interval

Set the interval before displaying the next picture. The length can be set up to 120 sec.

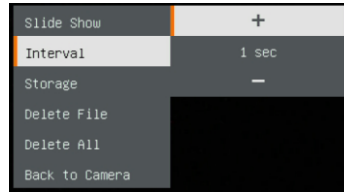

## Storage

Select the source of the images and videos.

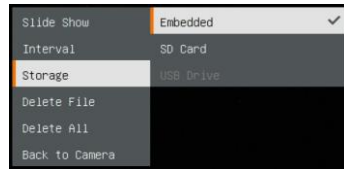

## Delete File

Permanently delete the image or video in selected. A Warning Message will appear. Select **Yes** to continue and **No** to cancel the deletion.

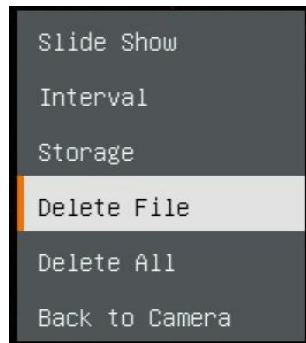
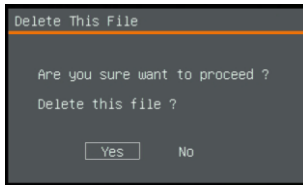

## Delete All

Permanently delete all the data in selected memory source. A Warning Message will appear. Select **Yes** to continue and **No** to cancel the deletion.

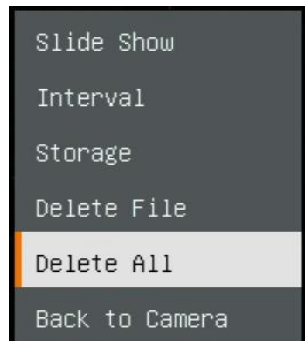
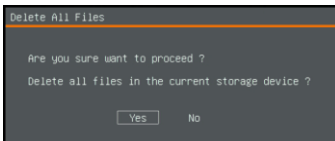



# Annotation

In single image playback mode, user can use the annotation feature to overlay straight line or freeform line on the captured image with the USB mouse connected to the USB port of M11-8MV.

**[Note]** Annotation function is not supported with video file.

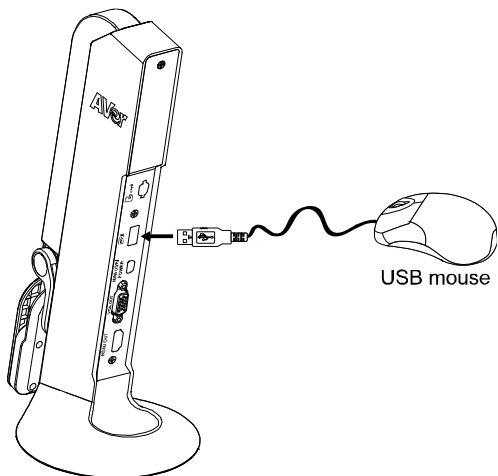
1. Connect the mouse to USB port of M11-8MV.



2. Press  to call out OSD menu.
3. Select "Playback".
4. Select the image and playback tool bar is displayed. Or right-click mouse to call out playback tool bar.

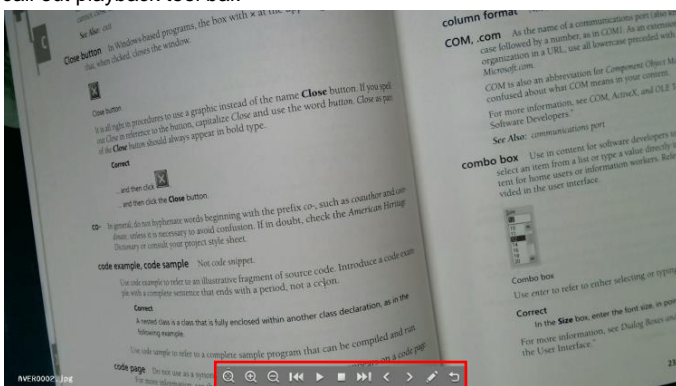









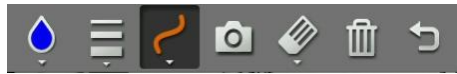
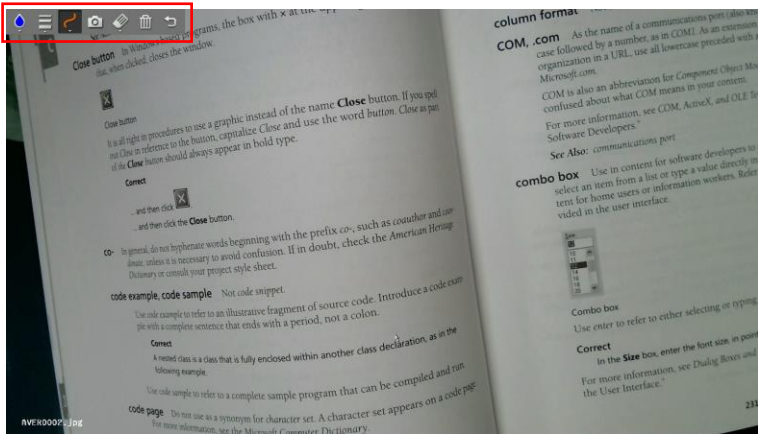

**Playback tool bar description**



Button	Function
	Move the image to left, right, up, and down. Select  to expand the direction buttons.
	Zoom in image
	Zoom out image
	Fast rewind
	Start to play video
	Stop playing video
	Fast forward
	Go to next or back to last image or file
	Switch to annotation function.
	Back to image or file list

5. To switch to annotation mode, select  on playback tool bar.



Button	Function
 Color Palette	Select the line color. 
 Line Thickness	Select the thickness of the line. 
 Line	Select a straight line, freehand or sharp to draw. 
 Capture	Capture the image with the annotation and save it as a new file.
 Eraser	Select to erase any part of the annotation that it comes in contact with or delete all annotation.
 Delete	Clear all annotation on the screen.
 Back	Back to playback tool bar.

# Use the Camera

## Camera Head Angle

Move the camera head as figure shown.

**[CAUTION]** To avoid damage the camera head, hold the edge of the camera head to rotation the camera head.

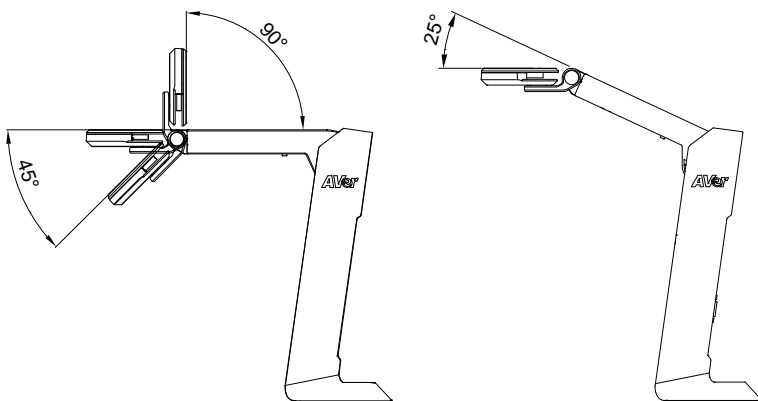
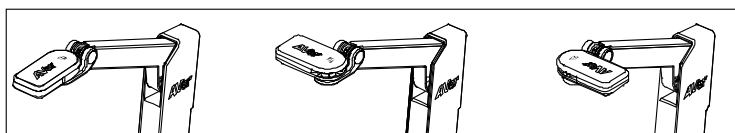

## Camera Body Angle

**[CAUTION]** To avoid damage the camera unit, **DO NOT** pull the arm angle over 107°.

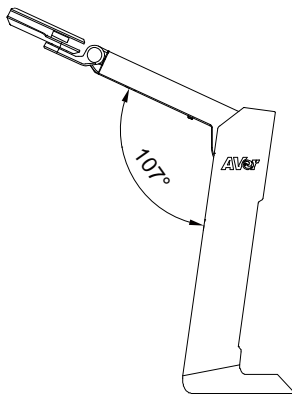

# Shooting Area

When camera position is 342.4mm high, the shooting area will be A3 size.

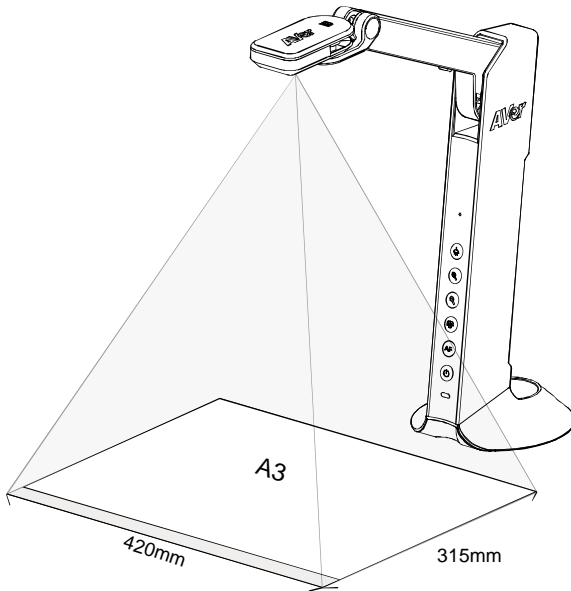
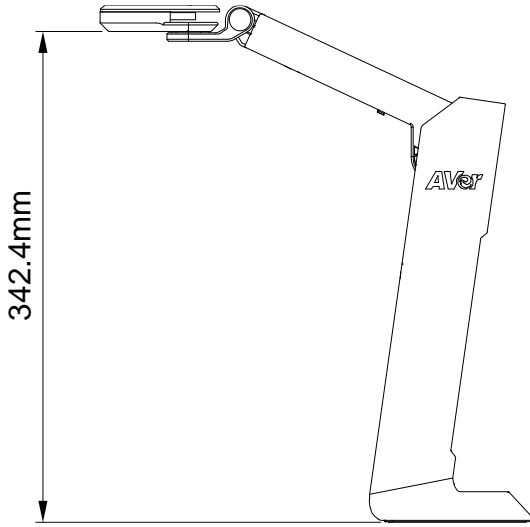

## Object Position

The icon on top of camera head can help user to place objects in a positive direction.

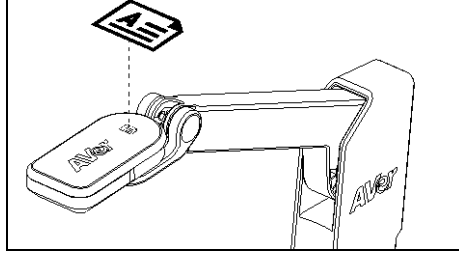

## Store the Camera

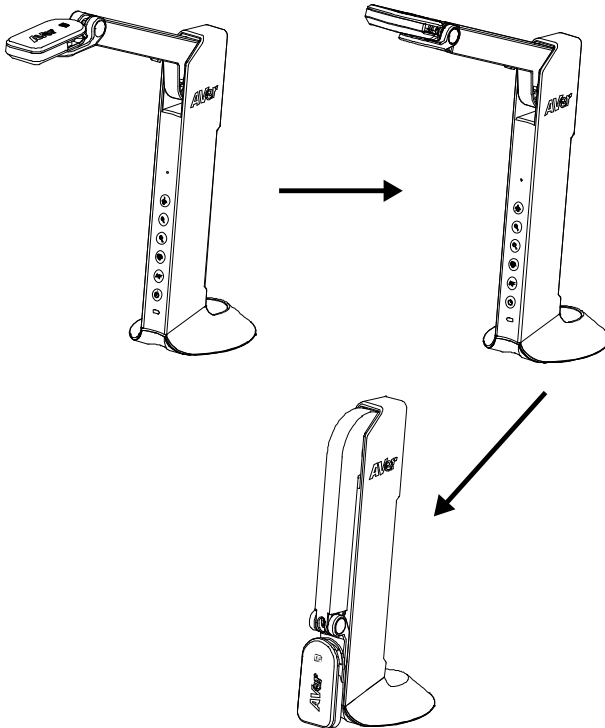

## Specification

Sensor	1/3.06" CMOS sensor
Pixel Count	8MP
Frame Rate	Max.60fps (display)
Image Mode	Normal / Motion / High Quality
Effect	Color / B&W / Negative
Focusing	Auto / Manual
Shooting Area	A3, 420mm (H) * 315mm (V)
Zooming	20x digital zoom
Power Source	Mini-USB in, 5V/1A
Consumption	4.5 Watts (lamp on) 4 Watts (lamp off)
USB Bus Power	Yes, via mini-USB port
Lamp Type	LED light
USB	USB2.0 Type-A x1 (< 5V/0.1A, USB flash drive FAT32, 32GB) USB Type mini-B x 1(Power)
USB Output	3168 x 2376, 1920 x 1080, 1280 x 720, 1024 x 768, 800 x 600, 640 x 480
HDMI Output	1920 x 1080, 1280 x 720, 720 x 480
VGA Output	1920 x 1080, 1280 x 720, 720 x 480
Image Capture	120 pictures (2 megapixel)
Built-in MIC	Yes
Micro SD Card Slot	FAT 32, 32GB
Operating	360.4mm (H) * 116.7mm (W) * 303.4mm (D)
Folded	296.1mm (H) * 116.7mm (W) * 143.1mm (D)
Net Weight	1.83 lbs (0.83 Kg)
Gross Weight	2.87 lbs (1.301 Kg)
Software Support	AVerTouch

## WARNING

- To reduce the risk of fire or electric shock, do not expose this appliance to rain or moisture. Warranty will be void if any unauthorized modifications are done to the product.
- Do not drop the camera or subject it to physical shock.
- Use the correct power supply voltage to avoid the damaging camera.
- Do not place the camera where the cord can be stepped on as this may result in fraying or damage to the lead or the plug.
- Hold the bottom of the camera with both hands to move the camera. Do not grab the lens or arm to move the camera.

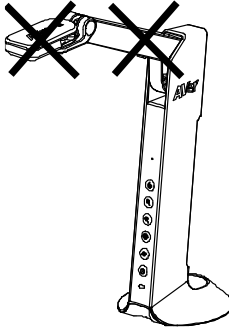

- Do not pull the camera arm and camera part in the opposite direction.

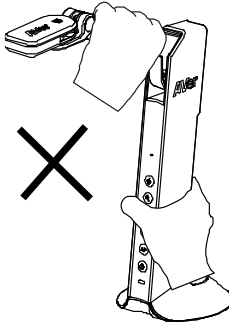

## COPYRIGHT

©2024 AVer Information Inc. All rights reserved.

## FEDERAL COMMUNICATIONS COMMISSION

NOTE: This equipment has been tested and found to comply with the limits for a Class A digital device, pursuant to part 15 of the FCC Rules. These limits are designed to provide reasonable protection against harmful interference when the equipment is operated in a commercial environment. This equipment generates, uses, and can radiate radiofrequency energy and, if not installed and used in accordance with the instruction manual, may cause harmful interference to radio communications. Operation of this equipment in a residential area is likely to cause harmful interference in which case the user will be required to correct the interference at his own expense.

FCC Caution: Any changes or modifications not expressly approved by the party responsible for compliance could void the user's authority to operate this equipment.

This device complies with part 15 of the FCC Rules.

Operation is subject to the following two conditions:

- (1) This device may not cause harmful interference, and
- (2) this device must accept any interference received, including interference that may cause undesired operation.

Warning:

This is a class A product. In a domestic environment this product may cause radio interference in which case the user may be required to take adequate measures.



THE MARK OF CROSSED-OUT WHEELED BIN INDICATES THAT THIS PRODUCT MUST NOT BE DISPOSED OF WITH YOUR OTHER HOUSEHOLD WASTE. INSTEAD, YOU NEED TO DISPOSE OF THE WASTE EQUIPMENT BY HANDING IT OVER TO A DESIGNATED COLLECTION POINT FOR THE RECYCLING OF WASTE ELECTRICAL AND ELECTRONIC EQUIPMENT. FOR MORE INFORMATION ABOUT WHERE TO DROP OFF YOUR WASTE EQUIPMENT FOR RECYCLING, PLEASE CONTACT YOUR HOUSEHOLD WASTE DISPOSAL SERVICE OR THE SHOP WHERE YOU PURCHASED THE PRODUCT.

## DISCLAIMER

No warranty or representation, either expressed or implied, is made with respect to the contents of this documentation, its quality, performance, merchantability, or fitness for a particular purpose. Information presented in this documentation has been carefully checked for reliability; however, no responsibility is assumed for inaccuracies. The information contained in this documentation is subject to change without notice.

In no event will AVer be liable for direct, indirect, special, incidental, or consequential damages arising out of the use or inability to use this product or documentation, even if advised of the possibility of such damages.

## More Help

For FAQs, technical support, software and instruction manual download, please visit:

### Non-USA

Download Center: <https://www.aver.com/download-center>

Technical Support: <https://www.aver.com/technical-support>

### USA

Download Center: <https://www.averusa.com/education/support>

Technical Support: <https://averusa.force.com/support/s/contactsupport>

## Contact Information

### Headquarters

AVer Information Inc.  
8F, No.157, Da-An Rd., Tucheng Dist.,  
New Taipei City 23673, Taiwan  
Tel: +886 (2) 2269 8535

### USA Branch Office

AVer Information Inc., Americas  
44061 Nobel Drive, Fremont, CA  
94538, USA  
Tel: +1 (408) 263 3828  
Toll-free: +1 (877) 528 7824

### Europe Branch Office

AVer Information Europe B.V.  
Westblaak 134, 3012 KM,  
Rotterdam, The Netherlands  
Tel: +31 (0) 10 7600 550

### Japan Branch Office

アバー・インフォメーション株式会社  
〒160-0023 日本東京都新宿区西新宿  
3-2-26 立花新宿ビル 7 階  
Tel: +81 (0) 3 5989 0290  
お客様サポートセンター(固定電話のみ):  
+81 (0) 120 008 382

### Vietnam Branch Office

Công ty TNHH AVer Information (Việt Nam)  
Tầng 5, 596 Nguyễn Đình Chiểu,  
P.3, Quận 3,  
Thành phố Hồ Chí Minh 700000, Việt Nam  
Tel: +84 (0) 28 22 539 211  
Hỗ trợ kỹ thuật: +84 (0) 90 70 080 77

### Korea Office

한국 에버 인포메이션 (주)  
서울시 종로구 새문안로 92  
(신문로 1가, 광화문오피시아빌딩)  
1831, 1832 호  
Tel: +82 (0) 2 722 8535

## 包裝內容物

請確定包裝中附有下列項目的物品。如有缺少的項目，請與你的經銷商連絡。

M11-8MV 機體

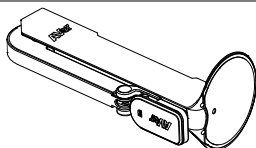

USB 連接線

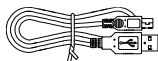

QR Code 卡



保固卡\*



\*只有歐洲、日本和台灣使用

## 選購配件

手提袋



防眩光片



## 硬體介紹

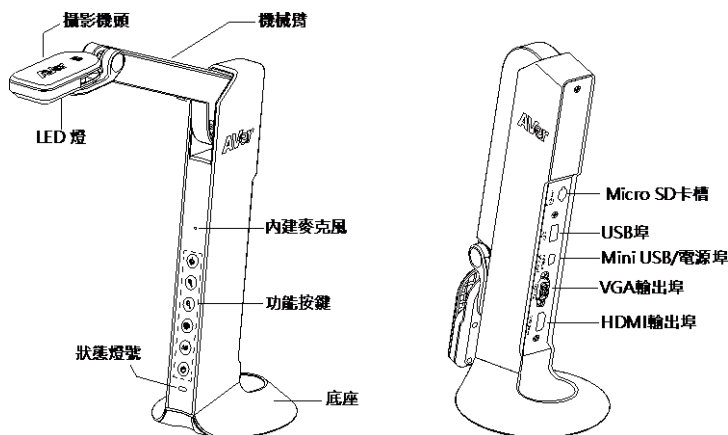





## 功能按鍵說明

### 面板功能鍵

按鍵	功能
	<ul style="list-style-type: none"> <li>■ 開啟/關閉 LED 燈</li> <li>■ 長按 3 秒呼叫 OSD 選單。</li> </ul>
	放大影像。
	縮小影像。
	<ul style="list-style-type: none"> <li>■ 旋轉 0° 或 180°</li> <li>■ 長按 3 秒可暫停螢幕影像。要解除，再長按 3 秒。</li> </ul>
	<ul style="list-style-type: none"> <li>■ 自動對焦。</li> <li>■ 長按 3 秒開始錄影。</li> </ul> <p>停止錄影，再次長按  鍵 3 秒。</p>
	電源開啟/關閉。

## OSD 模式功能按鍵

按鍵	功能
	<ul style="list-style-type: none"><li>■ 回到上一選單頁面。</li><li>■ 離開 OSD 選單。</li></ul>
	往上移動(選擇項目)。
	往下移動(選擇項目)。
	確認選擇。

## 複合鍵功能說明

同時按下按鈕可執行特定功能。

按鍵	功能
 + 	恢復到出廠預設值。
 + 	螢幕截圖。

[註] 當操作錄影和螢幕截圖時，請將 USB 連接電腦設定為「僅電源供應」模式。



## 狀態燈號

電源 	綠燈恆亮：已啟動
	紅燈恆亮：待機中
	紅燈閃爍：攝影機啟動中

## 設備連接

### 連接到牆上電源

1

插上電源並啟動 M11-8MV。

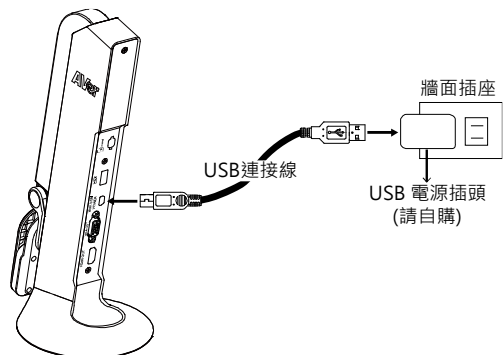

[註]

- 將包裝內的 USB 連接線與 USB 電源插頭(請自行購買)連接，然後一端連接到 M11-8MV 上的 USB/Power 埠，另一端插到牆面電源插座上。
- 請購買規格 5V/1A 的 USB 電源插頭跟 USB 連接線連接，並連接到牆面電源插座上。
- 當實物攝影機啟動時，狀態燈號為紅燈閃爍。

## 透過電腦/筆記型電供電

1 透過 USB/Power 埠與電腦/筆記型電腦連接。

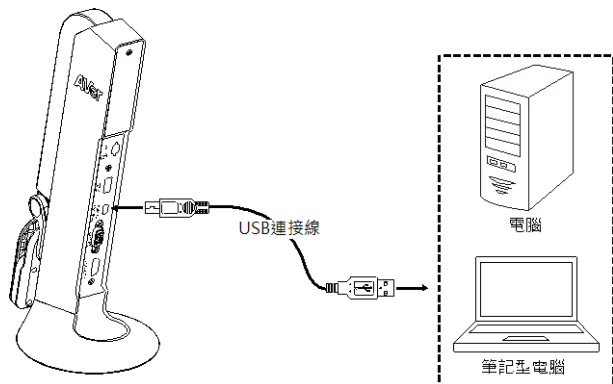

[註]

- 將包裝內的 USB 連接線與 M11-8MV 上的 USB/Power 埠連接，另一端連接到電腦/筆記型電腦的 USB 埠。
- 當實物攝影機啟動時，狀態燈號為紅燈閃爍。
- M11-8MV 的 USB 電源需求是 USB 5V/1A。
- 使用儲存、格式化、拍照、錄影和播放功能，請將 USB 連接電腦設定為「僅電源供應」模式。



## HDMI 連接

- 1 透過 HDMI 輸出埠將 M11-8MV 與 HDMI 輸出顯示設備連接。

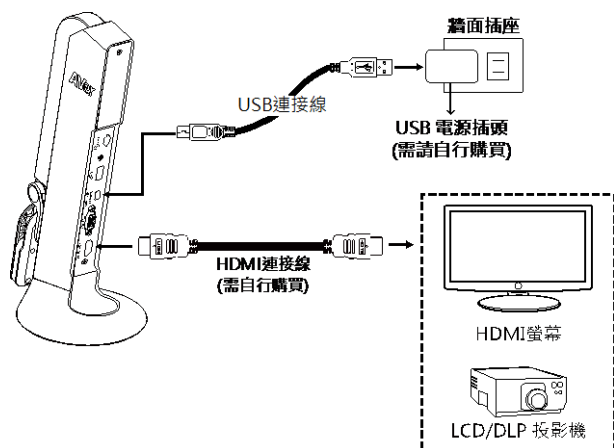

## VGA 連接

- 1 透過 VGA 輸出埠將 M11-8MV 與 VGA 輸出顯示設備連接。

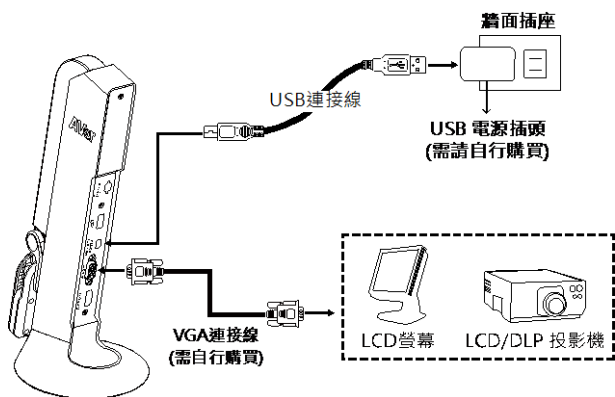

## USB 連接

- 1 將 USB 隨身碟插到 M11-8MV 上的 USB 埠，可用於儲存螢幕截圖和錄影檔案。

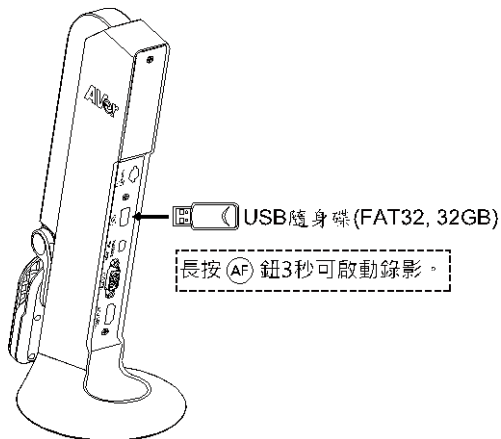

[註]最大可支援的 USB 隨身碟容量為 32G (FAT32)。

## 安裝 Micro SD 卡

- 1 將 Micro SD 卡插到 SD 卡插槽內。

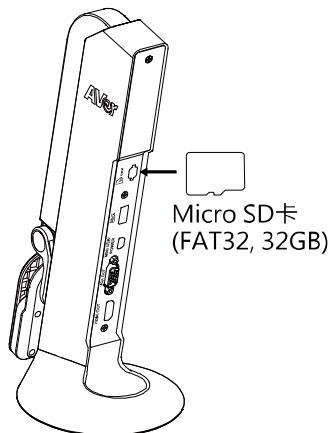

[註]

- Micro SD 卡可儲存螢幕截圖和錄影檔案。
- 最大可支援的 Micro SD 卡容量為 32G (FAT32)。

# 透過 AVer Touch 操作實物攝影機

1 將 M11-8MV 與電腦/筆記型電腦連接，並安裝 AVerTouch 軟體。

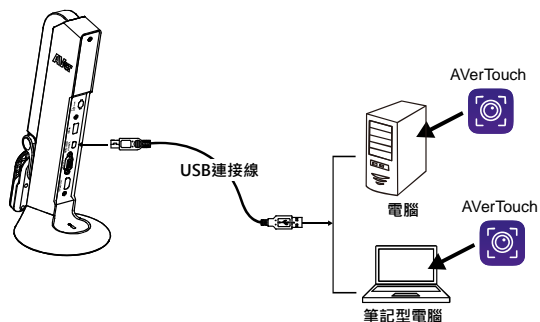

[註]

- 請在下面網址下載 AVerTouch 軟體：  
<https://tw.aver.com/download-center/>
- 請將實物攝影機模式設定為「USB 攝影機」。請到 OSD 選單中選擇「設定」>「USB 連接電腦」>「USB 攝影機」。



2 選擇  連接到實物攝影機。

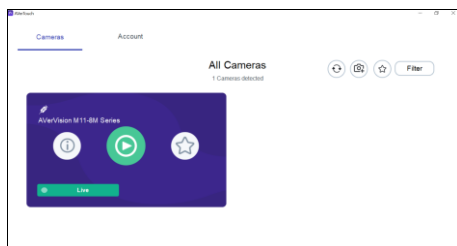

## 簡報模式(即時)

[註]使用簡報模式的註釋或子母畫面/畫面並排功能前，須先將攝影機設定在僅電源供應模式。請到 OSD 選單中選擇「設定」>「USB 連接電腦」>「僅電源供應」。

### 註解

使用者能夠在單張影像的即時（預覽）模式下，使用註解功能；將 USB 滑鼠連接至 M11-8MV 的 USB 埠，便可以在所擷取影像上繪製直線或自由形式的曲線。

1. 將滑鼠連接至 M11-8MV 的 USB 埠。

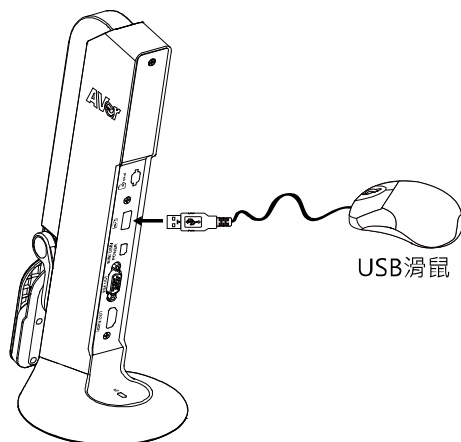

2. 請到 OSD 選單中選擇「簡報」>「註釋」。



3. 在即時畫面中，點擊滑鼠右鍵，叫出註解列。

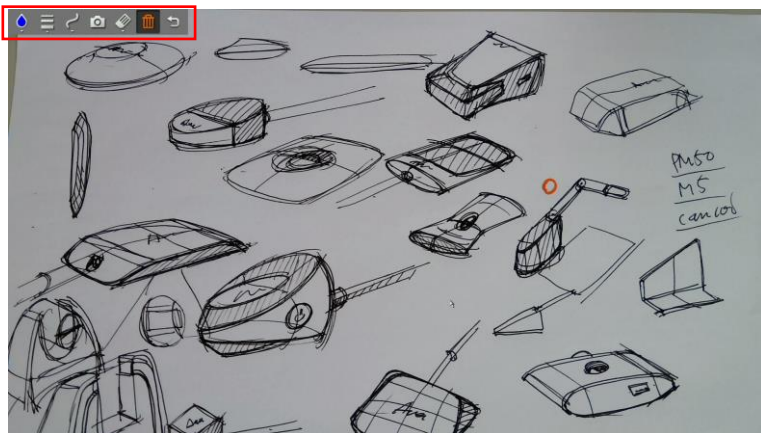



## 註解列說明



按鍵	功能
 調色盤	選擇線條顏色。 
 線條粗細	選擇線條粗細。 
 線條	選擇直線、手繪，或圖形以進行繪製。 
 擷取	使用註解擷取影像，並將其另存為新檔案。
 橡皮擦	此選項可刪除任何所接觸到的部分註解，或刪除所有註解。
 刪除	清除畫面上的所有註解。
 返回	退出註解列。

## 子母畫面功能

選擇縮圖播放畫面的位置，在畫面的角落顯示出縮圖播放畫面，從 SD 記憶卡中叫出擷取影像。

1. 在攝影機模式下，長按  按鍵 3 秒鐘，叫出 OSD 選單。
2. 使用  和  按鍵，移至「簡報」>「子母畫面」。按 **AF** 確認選擇。
3. 選擇縮圖播放畫面的顯示位置-左上、右上、左下或右下。按 **AF** 確認選擇。



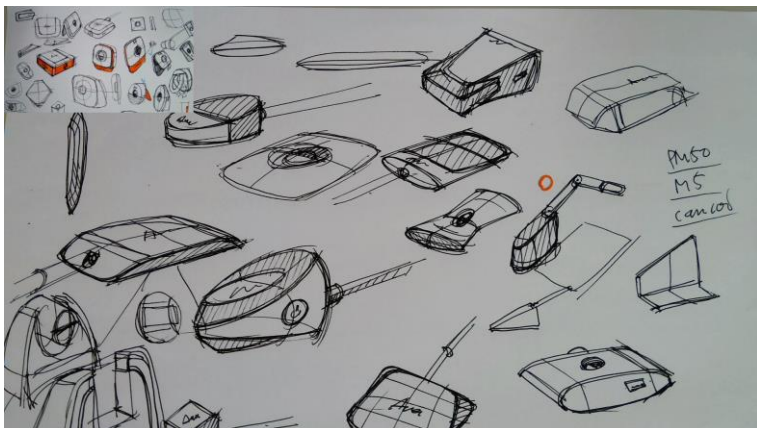

影像	子母畫面	左上
簡報	畫面並排	右上
設定	註釋	左下
播放		右下
系統		

4. 子母畫面顯示畫面如下所示。





## 多重畫面功能



選擇擷取影像的位置，在畫面上顯示所擷取影像，從 SD 記憶卡中叫出擷取影像。

1. 在攝影機模式下，長按  按鍵 3 秒鐘，叫出 OSD 選單。
2. 使用  和  按鍵，移至「簡報」>「多重畫面」。按  確認選擇。
3. 選擇縮圖播放畫面的顯示位置-左上、右上、左下或右下。按  確認選擇。

影像	子母畫面	上
簡報	畫面並排	下
設定	註釋	左
播放		右
系統		

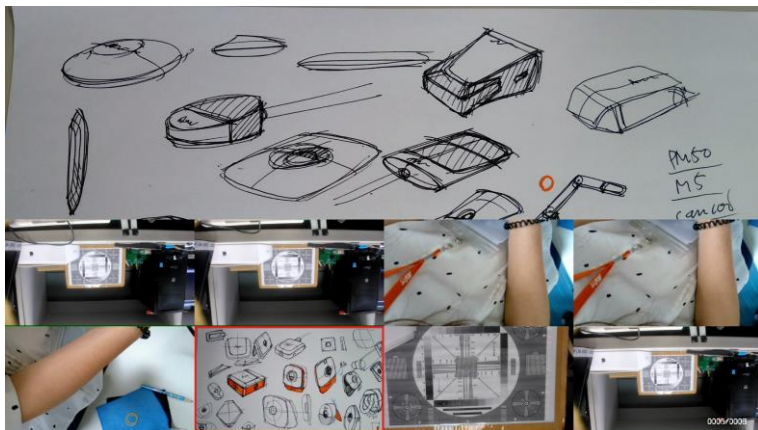
4. 使用  和  按鍵，從清單中選擇所擷取影像。



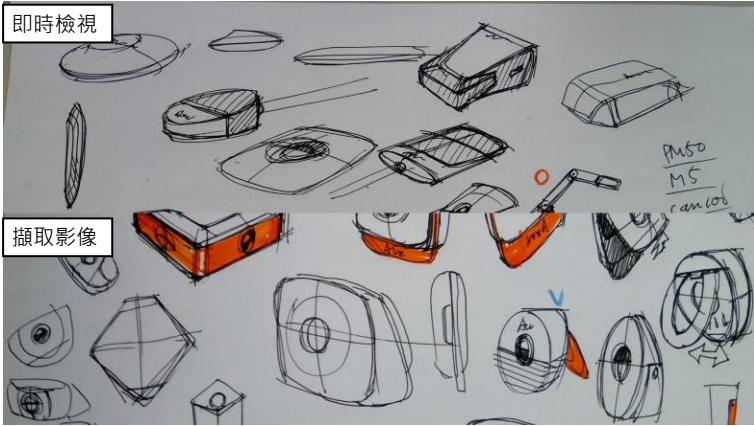

5. 多重畫面顯示畫面如下所示(多重畫面位於下方位置)。使用  和  按鍵，可以將所擷取影像上下移動以利檢視。













## 播放模式

可瀏覽螢幕截圖和錄影檔案。

### 切換到播放模式



1. 在攝影機模式下，長按  鈕 3 秒呼叫出 OSD 選單。
2. 使用  和  鈕來選擇「設定」>「USB 連接電腦」>「僅電源供應」。



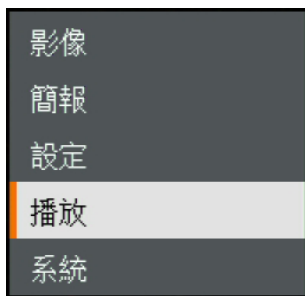













3. 使用 、 和  鈕來選擇「播放」選項。
4. 然後按  鈕確認，會切換到播放模式。
5. 在播放模式，使用  +  和  +  鈕來選擇要播放的照片或影片。要播放影片，按  鈕開始播放。要暫停播放，再次按  鈕。按  鈕停止播放。



## OSD 模式功能按鍵

按鍵	功能
	回到上一選單頁面。
	往上移動(選擇項目)。
	往下移動(選擇項目)。
	確認選擇。

## 播放模式功能按鍵

按鍵	功能
 + 	■ 照片或影片選擇
 + 	■  +  : 當播放影片時往前快轉。
 + 	■  +  : 當播放影片時快速倒轉。
	放大。
	縮小。
	■ 播放影片。 ■ 播放影片時，長按可暫停。
	停止播放影片。

## 幻燈片

在自動投影片播放中顯示所有拍攝的靜態圖片。視訊檔將會跳過。

幻燈片

間隔

儲存

刪除文件

刪除全部

返回相機

## 間隔

設定顯示下一張圖片之前的間隔時間。  
長度可以設定至最長 120 秒。

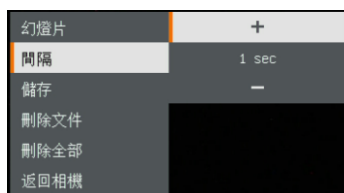

## 儲存

選擇影像來源。



## 刪除文件

永久刪除所選擇記憶來源中的資料。選擇「是」  
刪除所選資料，選擇「否」則會取消刪除資料。

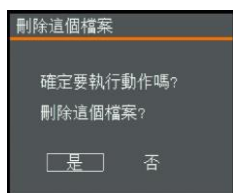

## 刪除全部

永久刪除所選擇記憶來源中的所有資料。選擇  
「是」刪除所選資料，選擇「否」則會取消刪除  
資料。

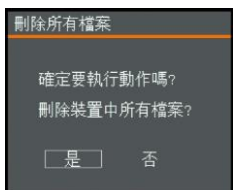



## 註解

使用者能夠在單張影像播放模式下，使用註解功能；將 USB 滑鼠連接至 M11-8MV 的 USB 埠，便可以在所擷取影像上繪製直線或自由形式的曲線。

[註]註解功能並不支援影片檔案。

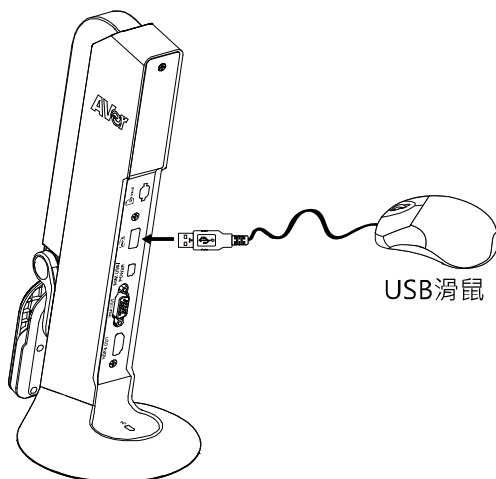
1. 將滑鼠連接至 M11-8MV 的 USB 埠。



2. 按  叫出 OSD 選單。
3. 選擇「播放」。
4. 選擇影像並顯示播放工具列。或是點擊滑鼠右鍵，叫出播放工具列。

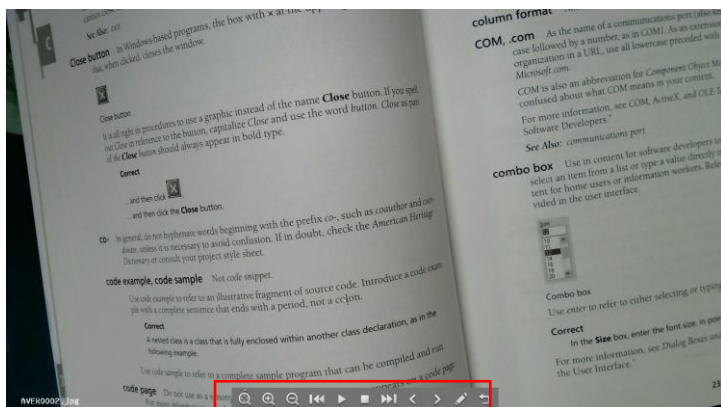

## 播放工具列說明



按鍵	功能
	將影像上、下、左、右移動。 選擇  展開方向按鍵。 
	放大影像
	縮小影像
	快速倒轉
	開始播放影片
	停止播放影片
	快速快轉
	轉至下一個或返回上一個影像或檔案
	切換至註解功能。
	返回影像或檔案清單

5. 若要切換至註解模式，請在播放工具列上選擇 。

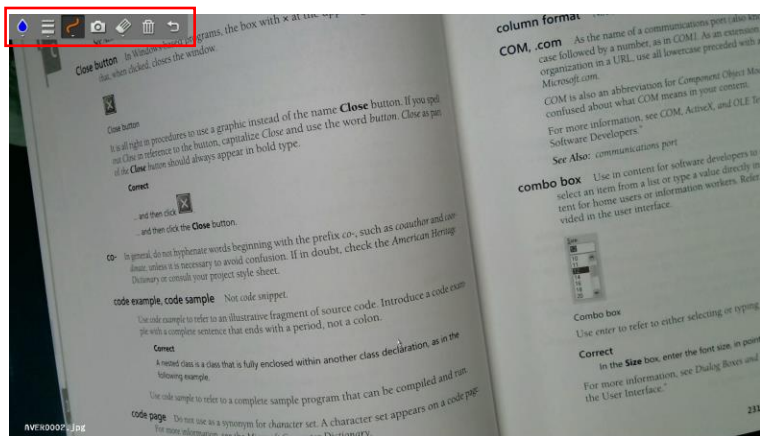

按鍵	功能
 調色盤	選擇線條顏色。 
 線條粗細	選擇線條粗細。 
 線條	選擇直線、手繪，或圖形以進行繪製。 
 擷取	使用註解擷取影像，並將其另存為新檔案。
 橡皮擦	此選項可刪除任何所接觸到的部分註解，或刪除所有註解。
 刪除	清除畫面上的所有註解。
 返回	返回播放工具列。

# 使用 M11-8MV

## 鏡頭角度

請照圖中所示旋轉鏡頭。

[注意] 為免損傷鏡頭，請將手抓在鏡頭的兩側來旋轉。

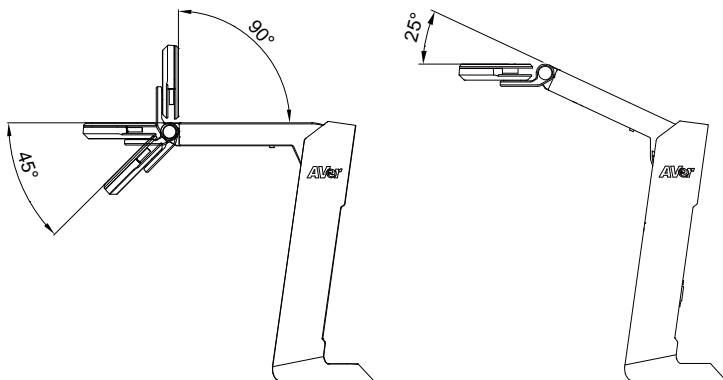
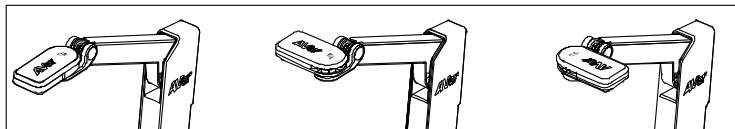

## 機身使用角度

[注意] 為免損傷攝影機，請勿將手臂角度展開超過 107°。

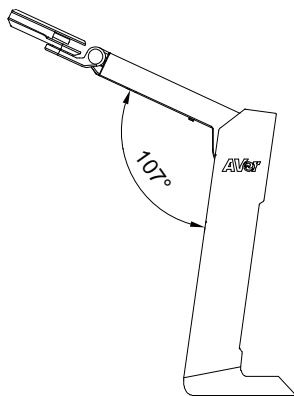

## 拍攝範圍

當鏡頭高度位於 342.4mm 時，此拍攝區域可觀賞最大範圍在 A3 內。

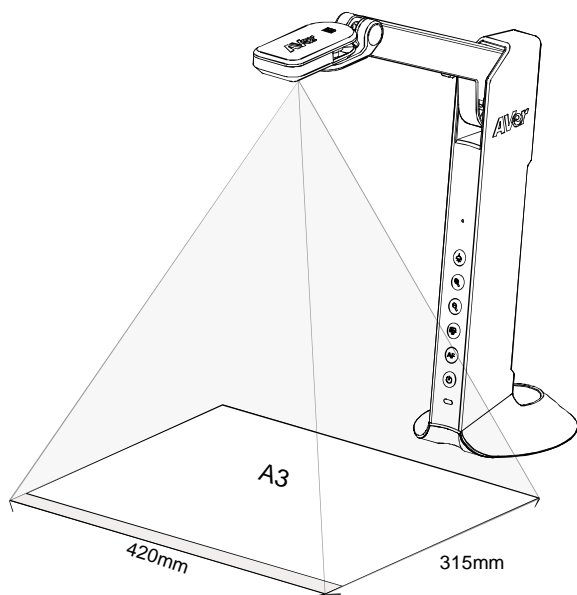
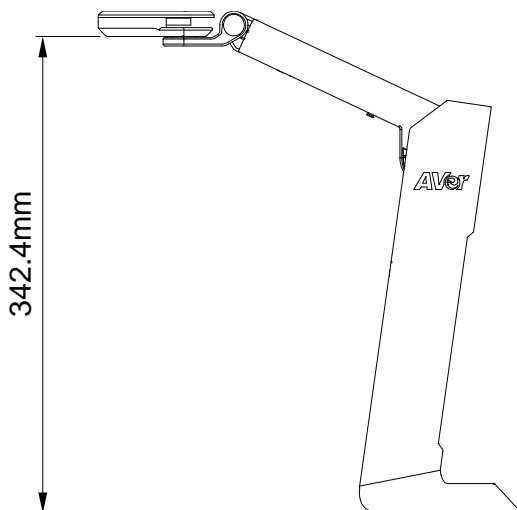

## 物體擺放位置

位於鏡頭上方的圖示可幫助使用者在擺放投射物體的位置為正方位。

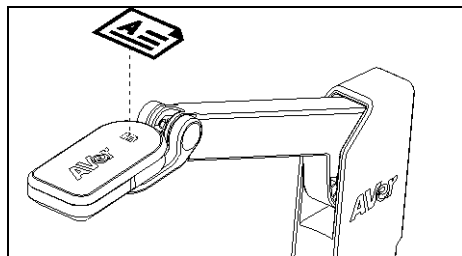

## 收納 M11-8MV

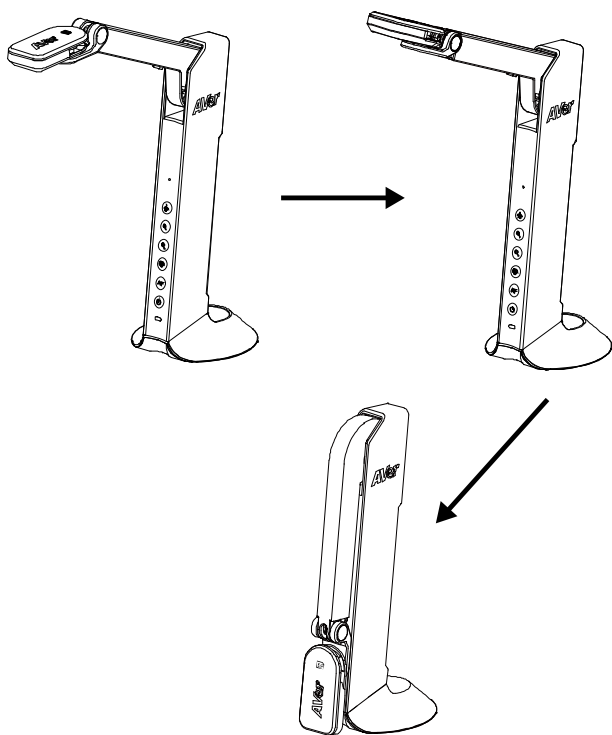

## 規格

感應器	1/3.06" CMOS
有效畫素	8MP
畫格速率	60 fps (最高)
影像模式	最佳/高品質/一般
效果	彩色/黑白/負片
對焦	自動/首覽
拍攝範圍	A3 · 420mm(H) * 315mm(V)
縮放倍數	20 倍數位縮放
電源	Mini-USB in · 5V/1A
耗電量	4.5 Watts(開燈) 4 Watts(關燈)
USB Bus Power	有 · 透過 mini-USB port
頂燈	LED 燈
USB	USB2.0 Type-A x1 (< 5V/0.1A · USB 隨身碟 FAT32, 32GB) USB Type mini-B x 1(電源)
USB 輸出	3168 x 2376 · 1920 x 1080 · 1280 x 720 · 1024 x 768 · 800 x 600 · 640 x 480
HDMI 輸出	1920 x 1080 · 1280 x 720 · 720 x 480
VGA 輸出	1920 x 1080 · 1280 x 720 · 720 x 480
影像截取	120 張(2 megapixel)
內建麥克風	有
Micro SD 卡插槽	FAT 32,32GB
使用時	360.4mm(高) x 116.7mm(寬) x 303.4mm(長)
收起後	296.1mm(高) x 116.7mm(寬) x 143.1mm(長)
淨重	1.83 磅(0.83 公斤)
重量	2.87 磅(1.301 公斤)
軟體支援	AVerTouch

## 警告

- 為降低火災或觸電風險，請勿將本產品暴露在雨中或潮濕環境中。如果對產品進行任何未經授權的修改，保固將無效。
- 請勿使機器掉落或受到撞擊。
- 請使用正確的電源電壓以避免損壞機器。
- 請勿將機器放在容易被踩到電源線的地方，否則可能會導致電源線或插頭磨損或損壞。
- 請用雙手握住機器底部以移動機器。請勿抓住鏡頭或機械臂來移動機器。
- 請勿往左右相反方向拉扯機械臂和機器本體。

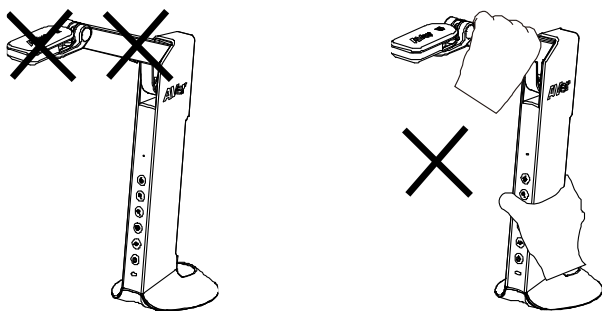

## 警告

為避免電磁干擾，本產品不應安裝或使用於住宅環境。

依經濟部標準檢驗局檢驗標準 CNS 15663 第 5 節「含有標示」之規定將限用物質含有情況標示如下：

單元Unit	限用物質及其化學符號					
	鉛 Lead (Pb)	汞 Mercury (Hg)	鎘 Cadmium (Cd)	六價鉻 Hexavalent chromium (Cr <sup>+6</sup> )	多溴聯苯 Polybrominated biphenyls (PBB)	多溴二苯醚 Polybrominate d diphenyl ethers (PBDE)
電路板及零組件(電子料或電機料...等)	-	○	○	○	○	○
塑膠組件(外殼或腳墊...等)	○	○	○	○	○	○
金屬組件(轉軸或螺柱...等)	-	○	○	○	○	○
光學鏡頭組	○	○	○	○	○	○
配件(電纜線...等)	-	○	○	○	○	○
紙製品(機殼貼紙...等)	○	○	○	○	○	○

備考 1. “○” 係指該項限用物質之百分比含量未超出百分比含量基準值。  
 Note 1 : “○” indicates that the percentage content of the restricted substance does not exceed the percentage of reference value of presence.

備考 2. “-” 係指該項限用物質為排除項目。  
 Note 2 : The “-” indicates that the restricted substance corresponds to the exemption.

## 免責聲明

對於產品品質、效能、適銷性或特定用途之適用性，本文件內容皆不代表任何明示或暗示保固或陳述。本文資訊經過仔細詳查，內容可靠無誤；雖然如此，若有任何錯誤，恕不負責。本文所含資訊如有變更，恕不另行通知。若因使用或不當使用本產品或本文，導致任何直接、間接、特殊、意外或後續損害，即使本公司已事先告知此類損害之可能性，亦不負任何賠償責任。

## 商標

AVer 為圓展科技股份有限公司之商標。因本內容之描述出現的商標分屬個別公司所有且均受智慧財產權相關法令保護。本文內所有提及之產品或企業名稱僅供識別與說明用途，且為各自擁有者之商標或註冊商標。

## 著作權

©2024 圓展科技 版權所有

本內容相關權利係圓展科技股份有限公司所有，任何人未得事先書面同意不得就本內容為一部或全部之重製、改作、或任何型式之散布行為。圓展科技股份有限公司保留變更產品規格及內容的權利無須另為通知。

## 資訊

技術問題、技術支援、軟體和使用指南下載，請連結下面網址：

文件/檔案/軟體下載：<https://tw.aver.com/download-center/>

技術支援：<https://tw.aver.com/technical-support>

## 連絡資訊

圓展科技股份有限公司

新北市 236 土城區大安路 157 號 8 樓

電話：(02) 2269-8535

## パッケージ同梱物

本製品には、以下の内容がパッケージに同梱されています。

同梱物に不備がありました場合、お手数ですが本製品をご購入頂きました購入した販売店まで、ご連絡ください。

M11-8MV 本体

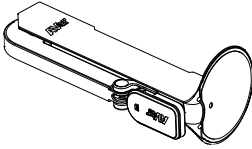

USB ケーブル

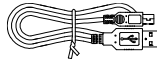

QR 印字カード



保証書\*



\*日本・ヨーロッパのみ

## オプション(別売)

キャリーバッグ



反射防止シート





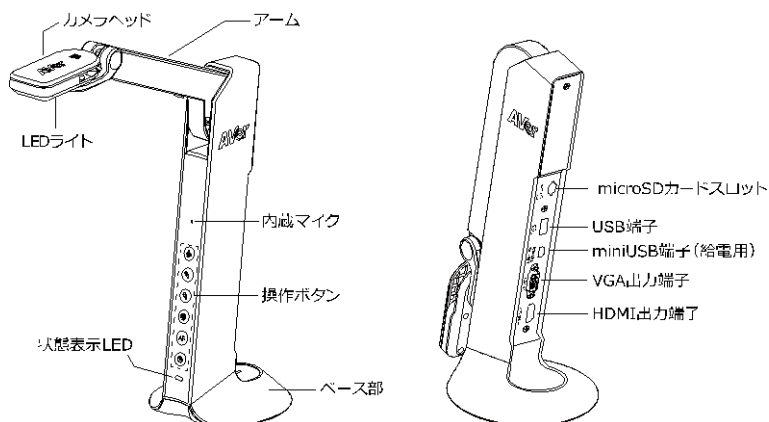



## ハードウェア部位 名称







## ボタン機能

### カメラ操作





ボタン	機能
	<ul style="list-style-type: none"> <li>LED ライトのオン・オフ</li> <li>3 秒長押しで、OSD メニューを表示します</li> </ul>
	ビデオ映像の拡大
	ビデオ映像の縮小
	<ul style="list-style-type: none"> <li>映像を 0 度から 180 度の範囲で回転します</li> <li>3 秒長押しで、カメラ映像を一時停止します。再度 3 秒長押しでカメラ映像を再開します。</li> </ul>
	<ul style="list-style-type: none"> <li>オートフォーカス</li> <li>3 秒長押しで録画開始・再度 3 秒長押しで録画終了</li> </ul>
	電源オン・オフ

## OSD モード時

ボタン	機能
	<ul style="list-style-type: none"><li>■ 一つ前の項目に戻る</li><li>■ OSD メニューを閉じる</li></ul>
	上の項目に選択を移動する
	下の項目に選択を移動する
	選択項目の決定

## ショートカットキー

複数のボタンを同時に押下します。

ボタン	機能
 + 	工場出荷時の設定状態に戻す
 + 	静止画の撮影

[注] 録画または静止画撮影を行う場合“**給電のみ**”を選択してください。

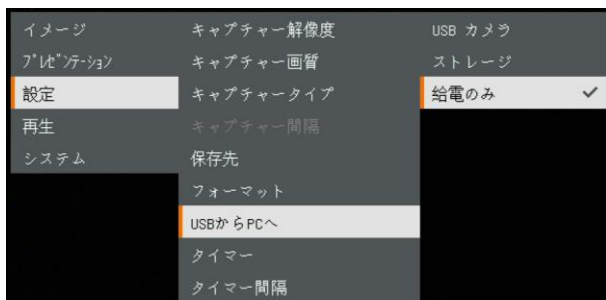

## LED 状態表示

電源 	緑点灯: 電源オン 赤点灯: スタンバイ状態 赤点滅: カメラ起動中
--	--

## 機器の配線

### 電源アダプタを使用し M11-8MV へ給電する場合

1 電源アダプタと USB ケーブルを接続し、M11-8MV の電源をオンにします。

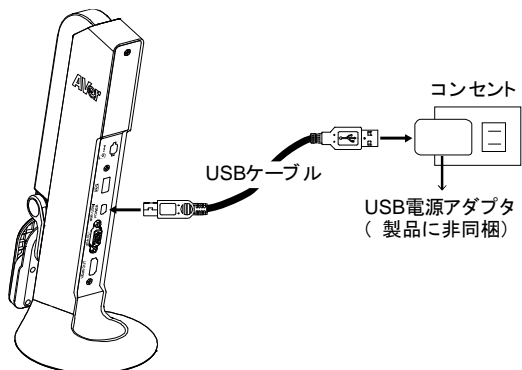

#### [注]

- 製品同梱の USB ケーブルを使用し、M11-8MV 給電用 miniUSB 端子と電源アダプタ(製品に非同梱)を接続します。
- 電源アダプタから給電を行う場合、市販の 5V/1A USB 電源アダプタをご購入ください。
- カメラ起動時、LED は赤色に点滅します。

## PC の USB 端子から M11-8MV へ給電する場合

- 1 付属 USB ケーブルを使用し、M11-8MV の給電用 miniUSB 端子と、PC の USB 端子を接続します。

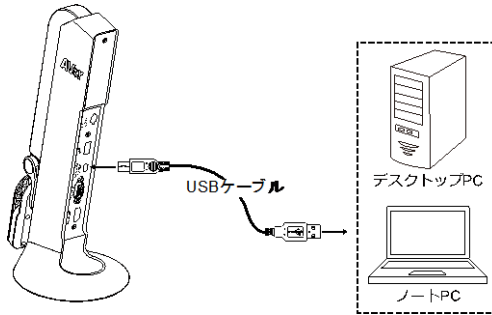

### [注]

- 製品付属の USB ケーブルを使用し、PC と M11-8MV を接続します。
- カメラ起動中、電源 LED は赤に点滅します。
- M11-8MV への給電には USB 端子から 5V/1A の給電が必要です。
- 保存・フォーマット・静止画保存・録画再生の機能を有効にする場合、設定の「給電のみ」の項目へ変更してください。

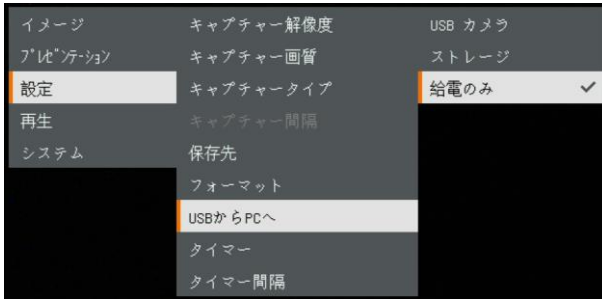

## HDMI 端子の接続

1

HDMI ケーブルを使用し、M11-8MV の HDMI 出力端子と HDMI 搭載ディスプレイを接続します。(HDMI ケーブルは製品に付属しません。)

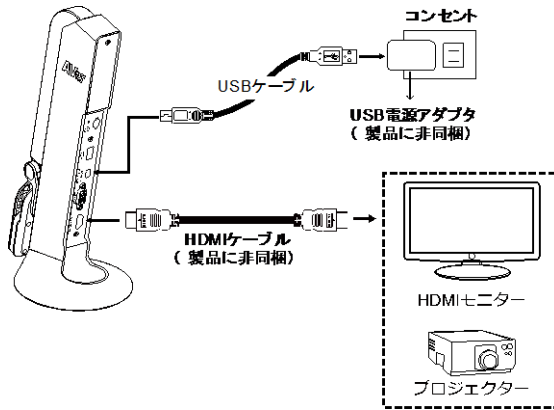

## VGA 端子の接続

1

VGA ケーブルを使用し、M11-8MV の VGA 端子と VGA 出力先機器を接続します。(VGA ケーブルは製品に付属しません。)

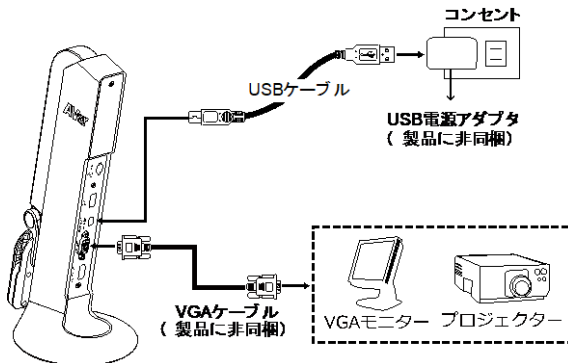

## USBドライブの使用

- 1 録画ファイルを保存する場合、  
本体 USB 端子に USB ドライブを接続します。

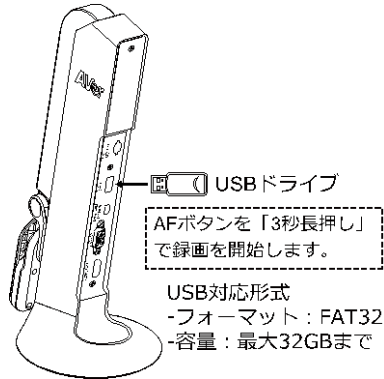

[注]USBドライブは最大 32GB まで(FAT32 形式)対応します。

## microSD の使用

- 1 カメラ本体の microSD カード差込口に microSD を挿入します。

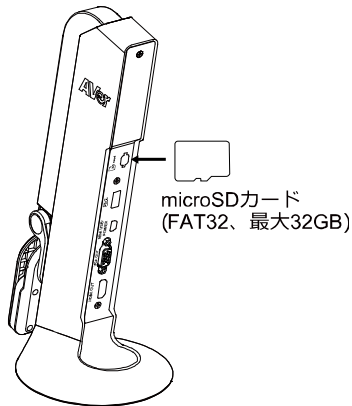

[注]

- microSD カードには撮影した画・録画ファイルが保存できます。
- microSD カードの対応容量は最大 32GB まで(FAT32)です。

# AVerTouch を使用し、カメラを操作する。

- 1 接続する PC に AVerTouch をインストールし、製品付属の USB ケーブルで接続します。

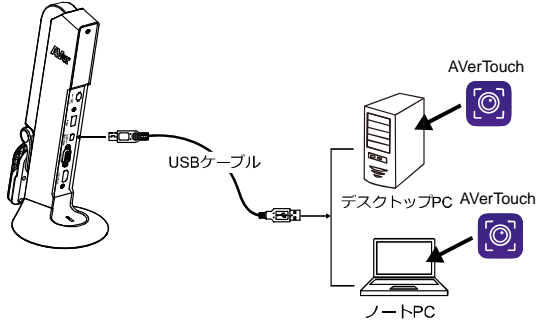

## [注]

- AVerTouch は下記 URL よりダウンロードいただけます。:  
<https://jp.aver.com/download-center/>
- カメラの設定を USB モードに変更してください。  
OSD メニュー > 設定 > USB から PC へ > USB カメラ を選択してください

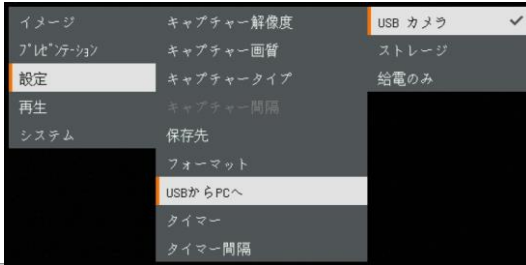

- 2 AVerTouch を立ち上げ、 をクリックしてカメラと接続します。

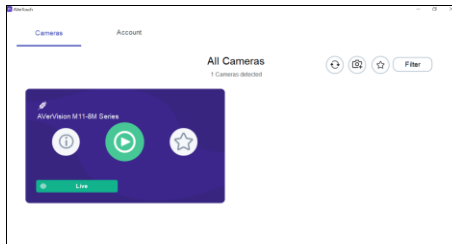

## プレゼンテーションモード(ライブ)

[注] 注釈機能またはPIP/PBP機能を使用する前に、カメラを「給電のみ」へ設定してください。

OSDメニュー> 設定 > USB から PC へ > 給電のみ を選択します。

### 注釈モード

注釈モードでは、M11-8MV の USB ポートに接続された USB マウスを使用し、キャプチャされた映像上に直線や書き込みを行う注釈機能を使用することができます。

1. マウスを M11-8MV の USB ポートに接続します。

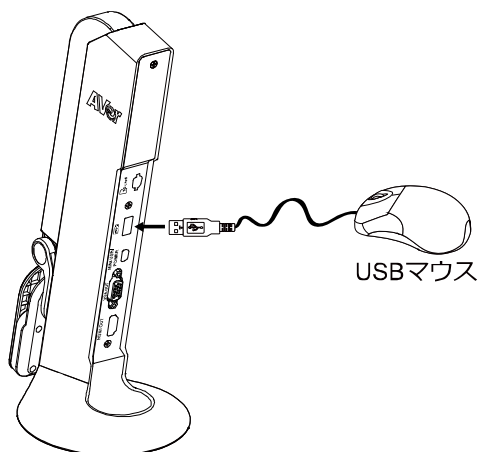

2. OSDメニュー > プレゼンテーション > 注釈 を選択します。



3. ライブ画面上でマウスを右クリックし、注釈バーを呼び出します。

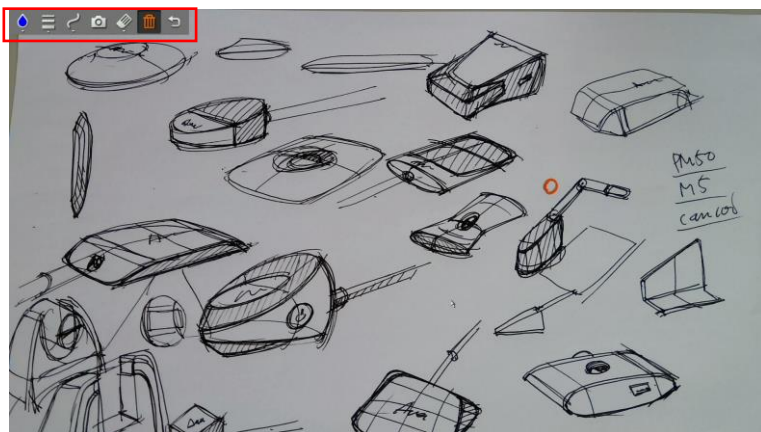





## 注釈バーの説明



ボタン	機能
 カラーパレット	線の色を選択します。 
 線の太さ	線の太さを選択します。 
 描画モード	直線、フリーハンド、またはシャープを選択して描画します。 
 キャプチャ	注釈が書き込まれた画像をキャプチャし、新しい画像ファイルとして保存します。
 消しゴム	このオプションを選択すると、注釈の一部が消去されるか、すべての注釈が削除されます。
 削除	画面上のすべての注釈をクリアします。
 戻る	注釈バーを終了します。

## PIP 機能

選択した再生画面の位置(画面の隅)に SD カードからキャプチャした画像を呼び出しサムネイル表示する機能です。

1. カメラモードで  ボタンを 3 秒長押しで OSD メニューを呼び出します。
2.  または  ボタンを使用して **プレゼンテーション** > **PIP** に移動します。  
。 を押して選択を確定します。
3. サムネイル再生画面の表示場所を選択します  
- **左上**、**右上**、**左下**、または**右下**。 を押して表示場所を決定します。



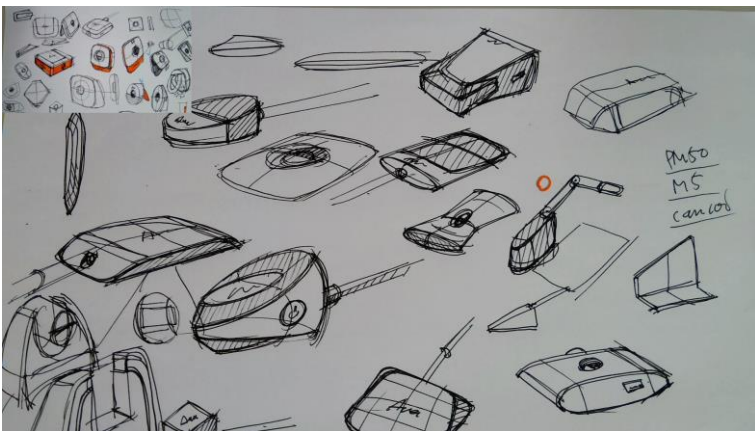

イメージ	PIP	左上
プレゼンテーション	PBP	右上
設定	注釈	左下
再生		右下
システム		

4. PIP 表示画面は下図のように表示されます。





## PBP 機能



キャプチャした画像の場所を選択し、キャプチャ画像を画面に表示して、SD カードからキャプチャした画像を呼び出します。

1. カメラモードで  ボタンを 3 秒長押しで OSD メニューを呼び出します。
2.  または  ボタンを使用してプレゼンテーション > PBP に移動します。  
 を押して選択を確定します。
3. サムネイル再生画面の表示場所を選択します  
-上、下、左、または右。  を押して選択を確定します。

イメージ	PIP	上
プレゼンテーション	PBP	下
設定	注釈	左
再生		右
システム		

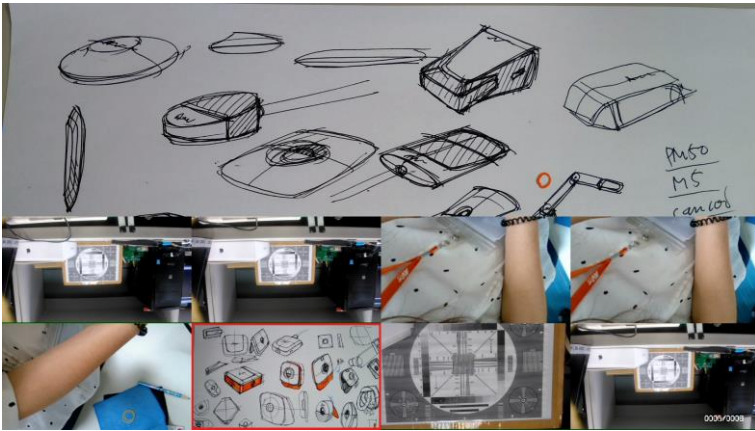
4. 一覧からキャプチャした画像を選択するには、  ボタンを使用します。



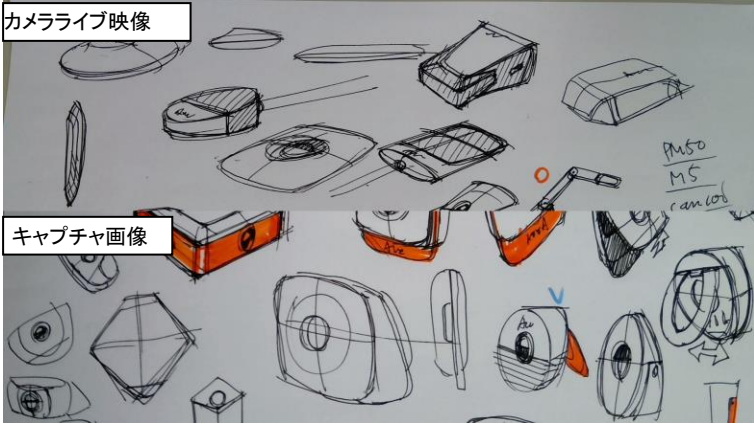

5. PBP 表示画面は下図のように表示されます。(PBP は下に表示)   ボタンを使用して、キャプチャした画像を上下に移動して表示します。











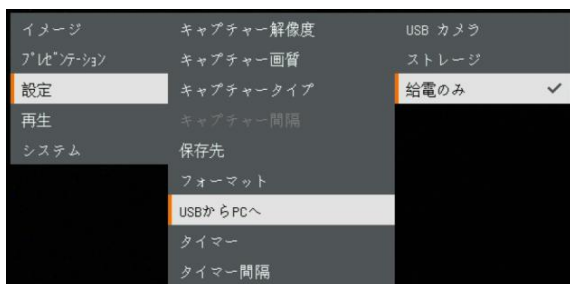



# プレイバックモード

撮影した画像/録画ファイルを開覧するモードです。

## プレイバックモードへの切替

1. カメラ本体の  ボタンを3秒長押しで、OSDメニューを呼び出します。
2.  ボタンと  ボタンを使用し **設定** > **USBからPCへ** > **給電のみ**の項目を選択します。





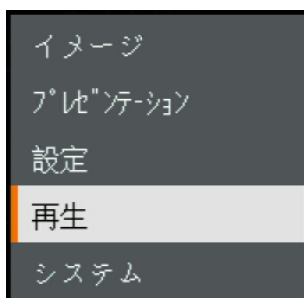











3.  と   ボタンを使用し、**再生**の項目へ移動します。
4.  ボタンを押し、**再生モード**に切り替えます。
5. **再生モード**では、 +  と  +  ボタンを押し、表示する画像またはビデオを選択します。ビデオを再生する場合は  ボタンを押し下さい。ビデオを一時停止する場合は再度  ボタンを押し下さい。  ボタンを押すと再生を終了します。



## OSD メニュー ボタン操作

ボタン	機能
	一つ前の項目に戻る
	選択項目を上へ移動
	選択項目を下へ移動
	選択項目の決定

## プレイバックモード ボタン操作

ボタン	機能
 + 	<ul style="list-style-type: none"> <li>■ 表示する画像/ビデオを選択</li> </ul>
 + 	<ul style="list-style-type: none"> <li>■  + : 再生ビデオ中に早送り</li> </ul>
 + 	<ul style="list-style-type: none"> <li>■  + : 再生ビデオ中に巻き戻し</li> </ul>
	画像の拡大
	画像の縮小
	<ul style="list-style-type: none"> <li>■ ビデオを再生</li> <li>■ ビデオ再生中に長押しで一時停止</li> </ul>
	ビデオの再生を終了

## スライドショー機能

すべてのキャプチャ画像と録画されたビデオを自動的に再生します。

動画はファイルのみが表示、再生はされません。

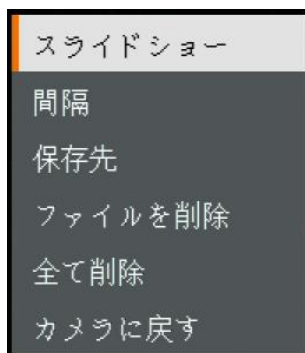

## 画像が切り替わる間隔の設定

次の画像を表示する前に間隔を設定します。長さは 120 秒まで設定できます。



## 再生に使用する保存先ストレージの指定

画像とビデオの再生に使用する保存先を選択します。



## ファイルの削除

選択した画像またはビデオを完全に削除します。警告メッセージが表示され、続行する場合は **[[はい]]** を、削除をキャンセルする場合は **[[いいえ]]** を選択します。

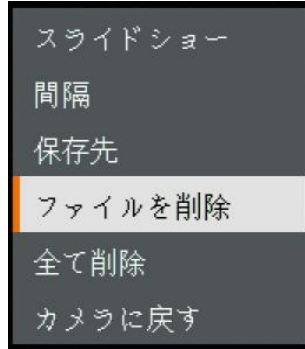
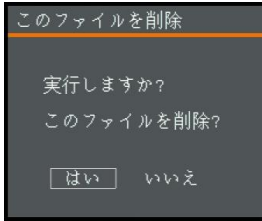

## ファイルをすべて削除

選択したストレージ内のすべてのデータを完全に削除します。警告メッセージが表示されます。続行する場合は **[[はい]]** を、削除をキャンセルする場合は **[[いいえ]]** を選択します。

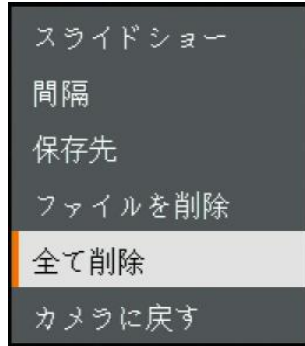
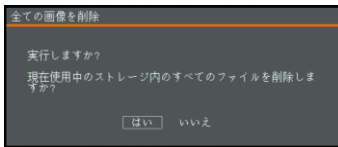



## 注釈モード

注釈モードでは、M11-8MV の USB ポートに接続された USB マウスを使用し、キャプチャされた映像上に直線や書き込みを行う注釈機能を使用することができます。

[注] 注釈機能は動画ファイルには対応していません。

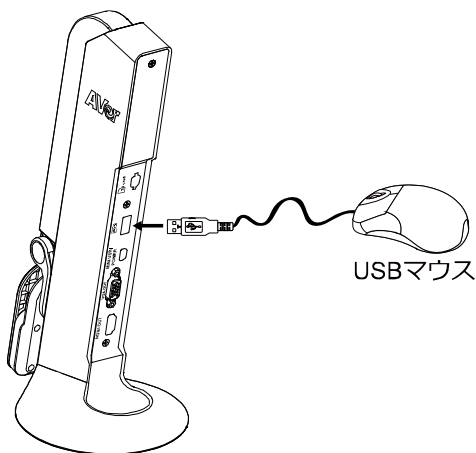
1. マウスを M11-8MV の USB ポートに接続します。



2.  を押し、OSD メニューを呼び出します。
3. 「再生」を選択します。
4. 画像を選択すると再生ツールバーが表示されます。またはマウスを右クリックして再生ツールバーを呼び出します。

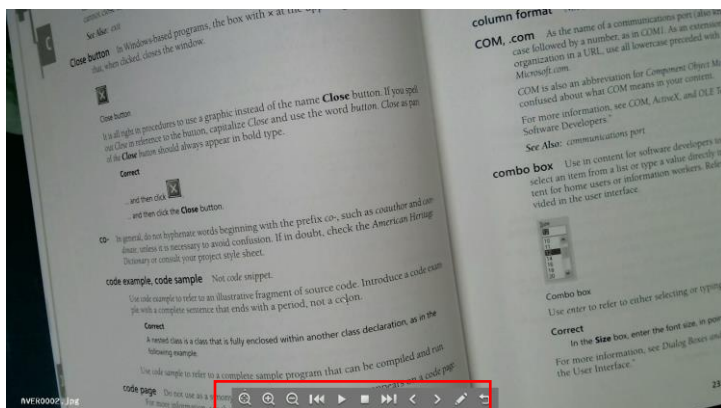

## 再生ツール バーの説明



ボタン	機能
	<p>イメージを左右、上、下に移動します。</p> <p> をクリックすると方向ボタンを展開します。</p>
	画像を拡大する
	画像を縮小する
	巻き戻し
	ビデオを再生する
	ビデオの再生を停止する
	早送り
	次または一つ前イメージ・ファイルに移動する。
	<p>注釈機能を切り替える。</p>
	画像またはファイル一覧に戻る

5. 注釈モードに切り替えるには、再生ツールバーで  を選択します。

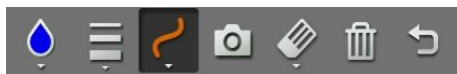
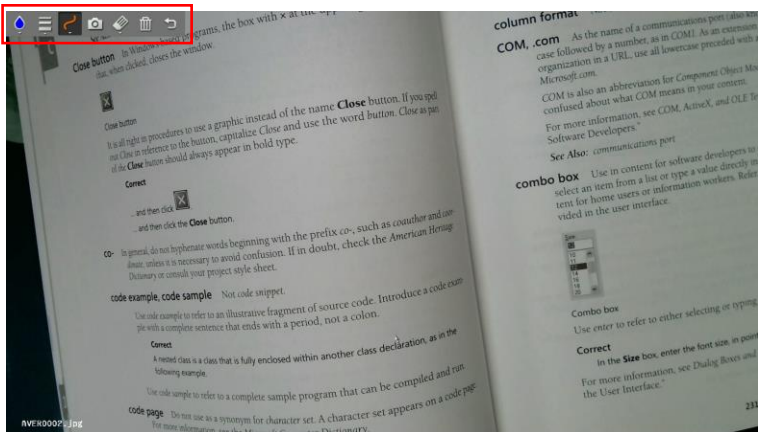

ボタン	機能
 カラーパレット	線の色を選択します。 
 線の太さ	線の太さを選択します。 
 描画モード	直線、フリーハンド、またはシャープを選択して描画します。 
 キャプチャ	注釈が書き込まれた画像をキャプチャし、新しい画像ファイルとして保存します。
 消しゴム	このオプションを選択すると、注釈の一部が消去されるか、すべての注釈が削除されます。
 削除	画面上のすべての注釈をクリアします。
 戻る	注釈バーを終了します。

# カメラの使用

## カメラヘッドの角度調節

下図のようにカメラヘッドを動かし、撮影範囲を調整します。

[注]カメラヘッドの故障を避けるため、カメラヘッドの端を押さえた状態でカメラヘッドを回転させてください。

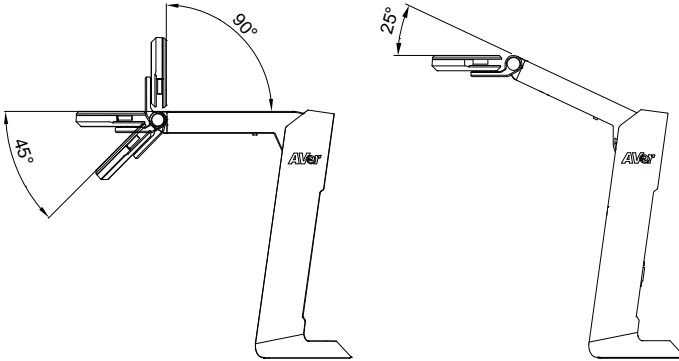
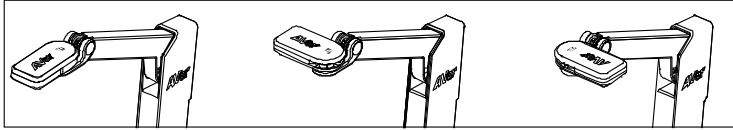

## カメラアーム部の角度調節

[注]カメラユニットの故障を避けるため、アームを107°以上の角度の範囲で動かさないでください。

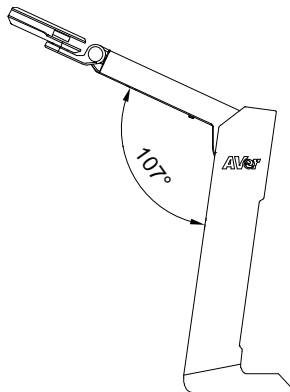

## 撮影範囲

カメラの位置が高さ 342.4mm の場合、撮影エリアは A3 サイズになります。

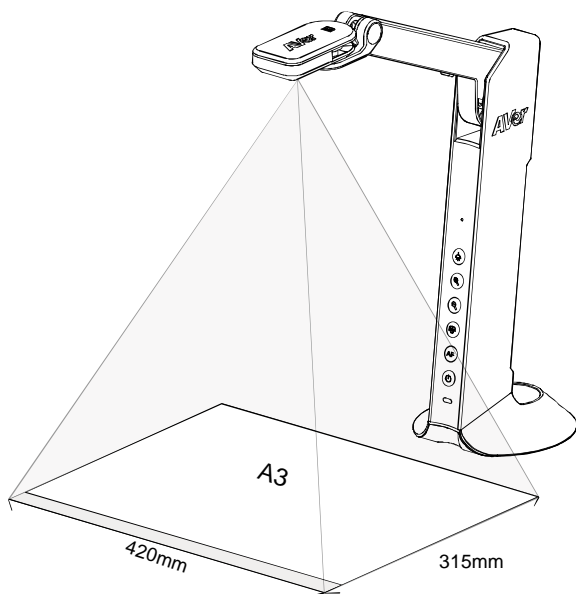
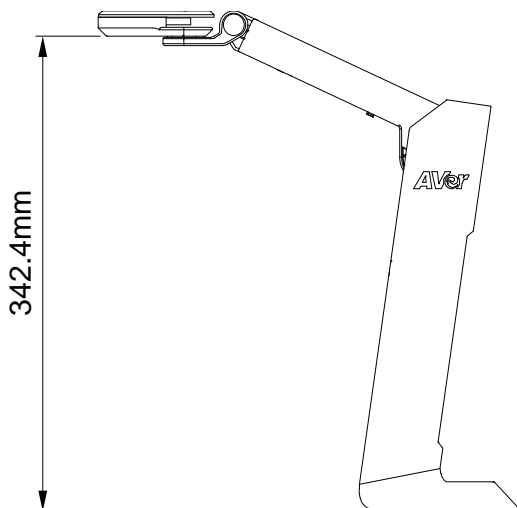

## 撮影方向

カメラヘッド上にあるマークの向きを参考に、撮影物を配置してください。

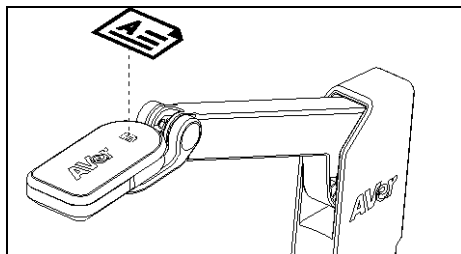

## カメラの収納

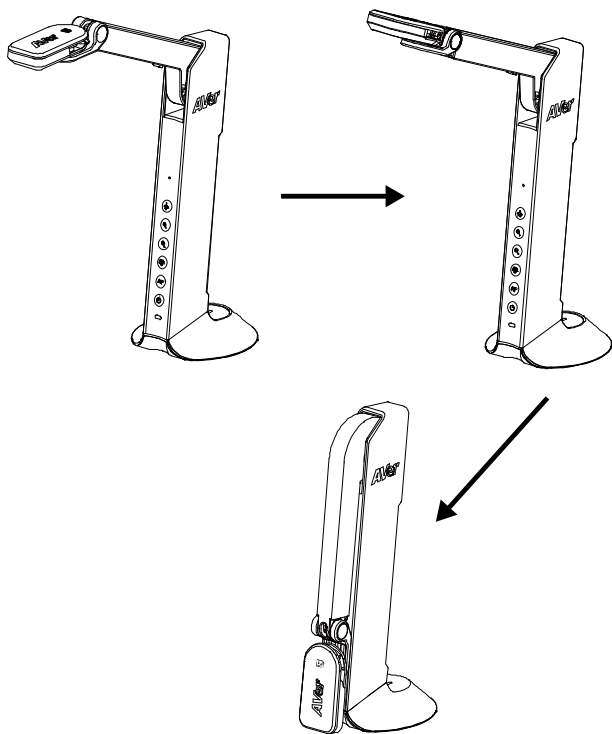

## 製品仕様

センサー	1 / 3.06 CMOS センサー
ピクセル数	8 メガピクセル(約 800 万画素)
フレームレート	最大 60fps
画像モード	ノーマル/モーション/高画質
効果	カラー/白黒/ネガ
フォーカス調整	自動/手動
撮影範囲	A3 サイズ,420mm(横)* 315mm(縦)
ズーム	20 倍デジタルズーム
電源仕様	mini USB 端子より給電(5V/1A)
消費電力	(照明 LED 点灯時)4.5W (照明 LED 消灯時)4W
USB パスパワー駆動	対応 (miniUSB 端子への給電)
照明タイプ	LED ライト
USB 仕様	USB2.0 Type-A x1 (< 5V/0.1A, USB ドライブ用 FAT32、最大 32GB まで) USB2.0 Type mini-B x 1 (給電用)
USB ビデオ出力	3168 x 2376、1920 x 1080、1280 x 720、1024 x 768、800 x 600、640 x 480
HDMI ビデオ出力	1920 x 1080、1280 x 720、720 x 480
VGA ビデオ出力	1920 x 1080、1280 x 720、720 x 480
画像キャプチャ	最大 120 枚(画質 2 メガピクセル)
内蔵マイク	搭載
マイクロ SD カード	最大 32GB まで(FAT 32 形式)対応
操作時の寸法	360.4mm(H)* 116.7mm(W)* 303.4mm(D)
収納時の寸法	296.1mm(H)* 116.7mm(W)* 143.1mm(D)
正味重量	1.83 lbs(0.83 Kg)
総重量	2.87 lbs(1.301 Kg)
ソフトウェアサポート	AVerTouch

### 使用上の注意

- 火災や感電を避けるため、この器具を雨や湿気にさらさないで下さい。製品に対して不正な変更が行われた場合、保証は無効になります。
- カメラを落下させるなど、物理的な衝撃を加えないでください。
- カメラの故障を避けるため、正しい電源電圧を使用してください。
- リードやプラグがほつれたり破損したりする可能性があるため、カメラをコードを踏むような場所に設置しないでください。
- カメラを動かす場合、カメラの下を片手で押さえてください。カメラヘッドやアームをつかんで、カメラを動かさないでください。

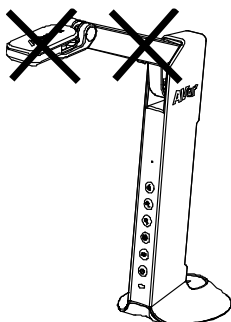

- カメラアームとカメラパーツを反対方向に引っ張らないでください。

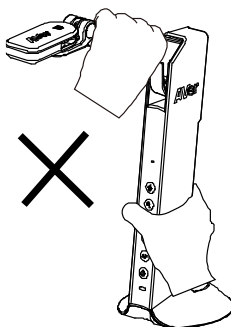

### 著作権

©2024 AVer Information Inc. 本書の著作権を保有します。

### 告知

仕様は事前の通知なしに変更されることがあります。

ここに含まれる情報は参考としてご利用ください。

### 商標

「AVer」は、AVer Information Inc.が所有する商標です。ここで記載されている目的で使用されているその他の商標は、同社にのみ属しています。

## 注意

本製品のバッテリーは、**お客様**自身では交換できない仕様になっており、**バッテリー交換**は別途有償となります。バッテリーの交換をご依頼いただく場合、製品をご購入いただきました販売代理店までご連絡ください。適合外のバッテリーへ交換を行った場合、破損の危険があります。指示に従って使用済み電池を処分してください。

## VCCI-A

この装置は、クラスA機器です。この装置を住宅環境で使用すると電波妨害を引き起こすことがあります。

この場合には使用者が適切な対策を講ずるよう要求されることがあります。

## 連絡先

アバー・インフォメーション株式会社

〒160-0023 日本東京都新宿区西新宿 3-2-26

立花新宿ビル 7 階

Tel: +81 (0) 3 5989 0290

お客様サポートセンター(固定電話のみ): +81 (0) 120 008 382

## ヘルプ詳細

FAQ、テクニカルサポート、ソフトウェア、および取扱説明書のダウンロードは、下記 URL よりご利用いただけます。

**Global:**

<https://www.aver.com/download-center/>

**日本**

<https://jp.aver.com/>

**技術的なご質問・**

<https://jp.aver.com/technical-support>

**修理のご依頼:**

<https://jp.aver.com/repair-request>

## Inhalt Der Verpackung

Die folgenden Artikel sind Bestandteile dieses Produktes. Falls ein Teil fehlen sollte, wenden Sie sich bitte an den Händler, bei dem Sie dieses Produkt erworben haben.

M11-8MV-Gerät

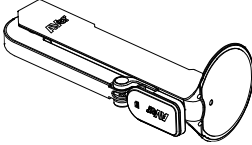

USB-Kabel

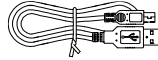

QR-Code-Karte



Garantiekarte\*



\* Nur für Europa, Japan, Taiwan

## Optionales Zubehör

Tragetasche



Blendschutz





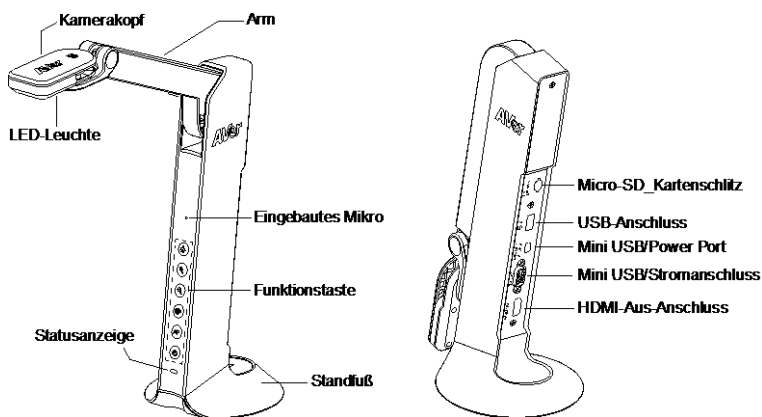



# Übersicht







## Funktionstasten

### Bedienfeld





Taste	Funktion
	<ul style="list-style-type: none"> <li>■ Lampe ein/aus</li> <li>■ 3 Sekunden gedrückt halten, um das OSD-Menü aufzurufen</li> </ul>
	Vergrößerung
	Verkleinerung
	<ul style="list-style-type: none"> <li>■ Drehen 0/180°</li> <li>■ Für das Standbild 3 Sekunden gedrückt halten. Erneut 3 Sekunden gedrückt halten, um das Standbild zu beenden</li> </ul>
	<ul style="list-style-type: none"> <li>■ Auto-Fokus</li> <li>■ Für den Beginn der Aufnahme 3 Sekunden gedrückt halten.</li> </ul> <p>Erneut 3 Sekunden drücken und  gedrückt halten, um die Aufnahme zu beenden</p>
	Ein-/Ausschalten

## OSD-Modus

Taste	Funktion
	<ul style="list-style-type: none"><li>■ Zurück zur letzten Menüebene</li><li>■ OSD-Menü beenden</li></ul>
	Nach oben (Auswahlelement)
	Nach unten (Auswahlelement)
	Auswahl eingeben

# Verbundtaste

Die Tasten für die Aktivierung der Verbundtastenfunktion drücken

Taste	Funktion
 + 	Zurücksetzen auf die Werkseinstellungen.
 + 	Bild erfassen

**[Hinweis]** Für **Aufzeichnen** und **Erfassen** wechseln Sie bitte zum Modus „**Nur Stromversorgung**“.

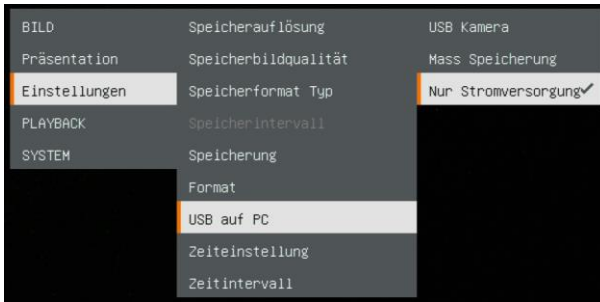

# LED-Leuchte

<b>Leistung</b> 	<b>Statisch grün:</b> Eingeschaltet <b>Statisch Rot:</b> Standby <b>Blinkt rot:</b> Die Kamera ist im Einschaltmodus.
---	---

# Geräteanschluss

## Stromanschluss über dieWandsteckdose

1

Verbinden Sie das Netzteil und schalten Sie die M11-8MV ein.

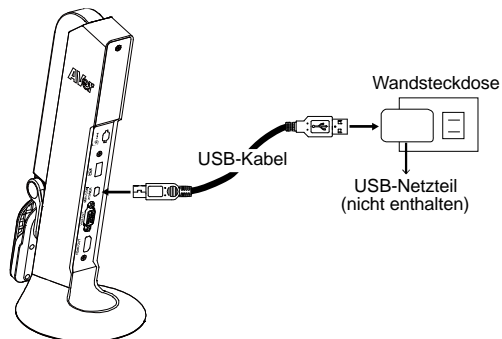

### [Hinweis]

- Das beiliegende USB-Kabel wird über den Mini-USB/-Stromanschluss an der M11-8MV mit dem USB-Netzteil (nicht beiliegend) mit Verbindung zur Wandsteckdose verwendet.
- Der Benutzer muss ein Netzteil (5 V/1 A) (nicht beiliegend) für die Verbindung des USB-Kabels mit der Wandsteckdose erwerben.
- Sobald die Kamera startet, blinkt die Netzanzeige rot.

# Stromanschluss am PC/Laptop

1 Verbindung mit dem USB-Anschluss von PC/Laptop für die Stromversorgung.

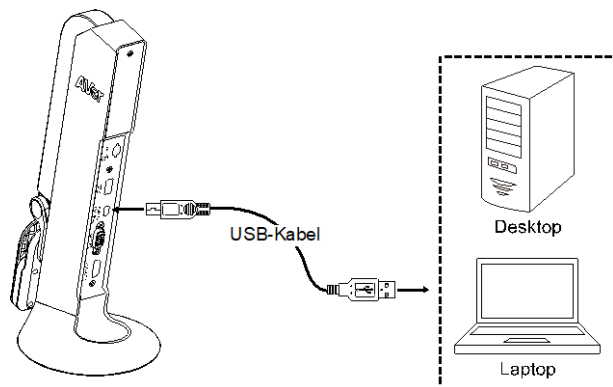

## [Hinweis]

- Verwenden Sie das beiliegende USB-Kabel für die Verbindung eines PC/Laptops über den Mini-USB/-Stromanschluss an der M11-8MV.
- Sobald die Kamera startet, blinkt die Netzanzeige rot.
- USB-Leistungsbedarf der M11-8MV: USB 5 V/1 A.
- Für die Funktionen Speichern, Formatieren, Erfassen, Aufzeichnen und Wiedergabe wechseln Sie bitte zum Modus „Nur Stromversorgung“

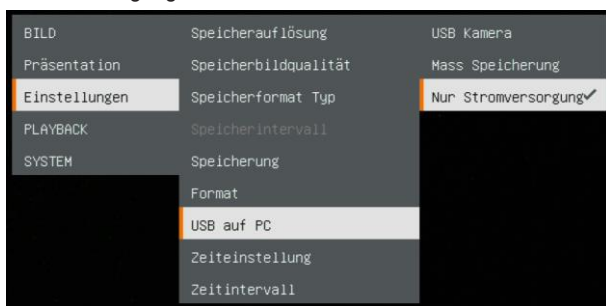

## HDMI-Verbindung

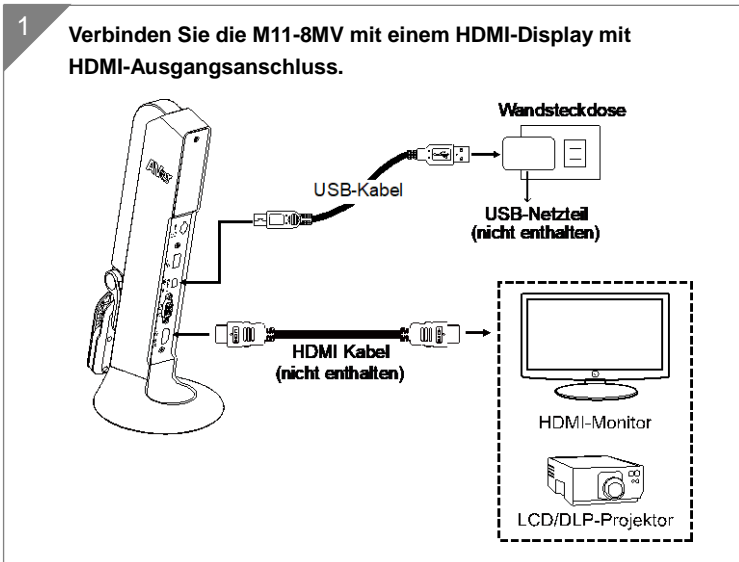

## VGA-Verbindung

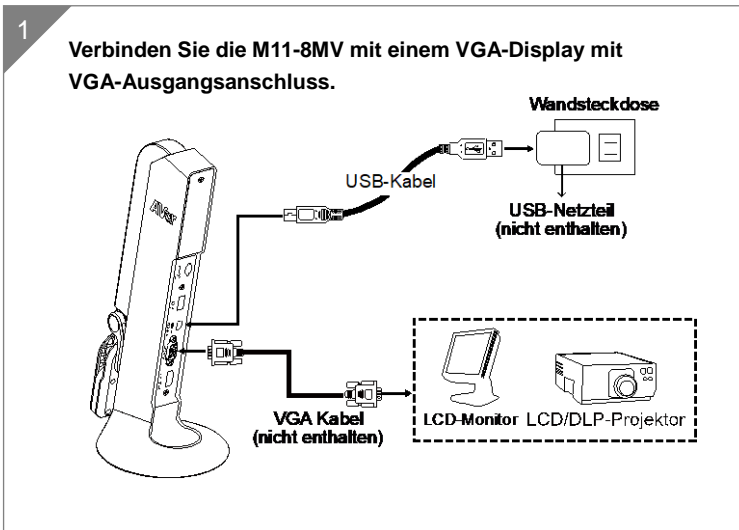

## USB-Verbindung

- 1 Verbinden Sie den USB-Stick für die Erfassung und Speicherung der Datei mit dem USB-Anschluss.

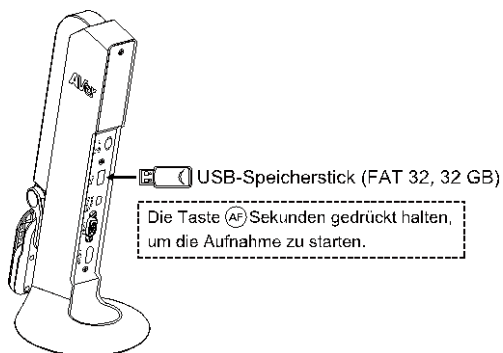

**[Hinweis]** Es wird ein USB-Speicherstick mit maximal 32G (FAT32) unterstützt.

## Einlegen der Micro-SD-Karte

- 1 Setzen Sie die Karte in den Micro-SD-Kartenslot ein.

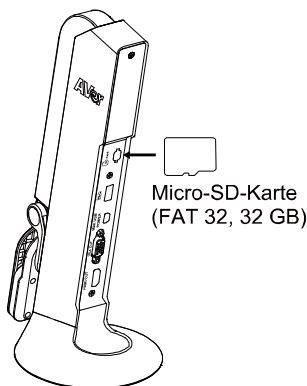

### **[Hinweis]**

- Micro SD-Karte für die Speicherung von erfassten Bild- und Aufnahme Dateien.
- **[Hinweis]** Es wird eine Micro-SD-Karte mit maximal 32G (FAT32) unterstützt.

# Bedienung der Kamera mit AVerTouch

- 1 Verbinden Sie die Kamera mit dem PC/Laptop und installieren Sie die AVerTouch-App.

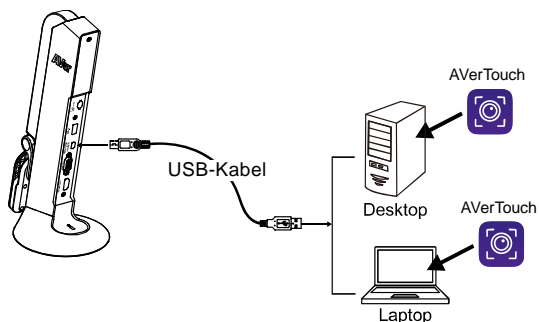

## [Hinweis]

- Laden Sie die AVerTouch-App hier herunter:  
<https://www.avereurope.com/download-center/>
- Schalten Sie die Kamera in den USB-Modus. Öffnen Sie **OSD-Menü > Einstellung > USB an PC > USB-Kamera**.

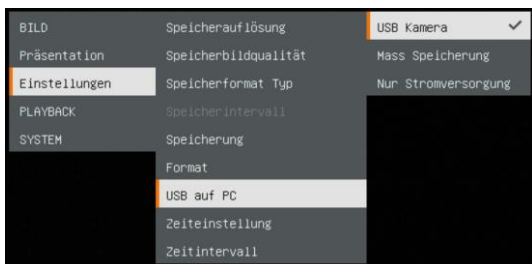

- 2 Öffnen Sie die AVerTouch-App und klicken Sie auf , um die Kamera zu verbinden.

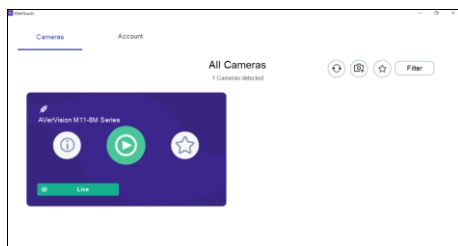

## Präsentator-Modus (Live)

**[Hinweis]** Schalten Sie die Kamera vor der Verwendung der Kommentar- oder PIP/PBP-Funktion des Präsentationsmodus bitte zuerst in den Modus " Nur Stromversorgung". Öffnen Sie **OSD Menü > EINSTELLUNG > USB an PC > Nur Stromversorgung**.

### Kommentieren

Während der Einzelbildanzeige (Vorschau) können Sie eine gerade oder eine Freiformlinie über das erfasste Bild legen; dazu verwenden Sie die USB-Maus am USB-Anschluss von M11-8MV.

1. Verbinden Sie die Maus mit dem USB-Anschluss der M11-8MV.

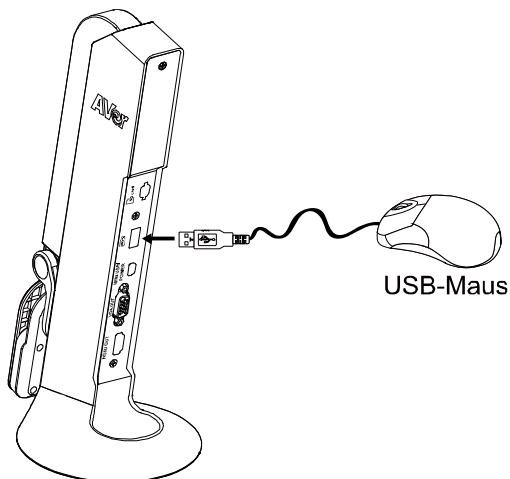

2. Gehe zu **OSD Menü > Präsentation > Anmerkung**.





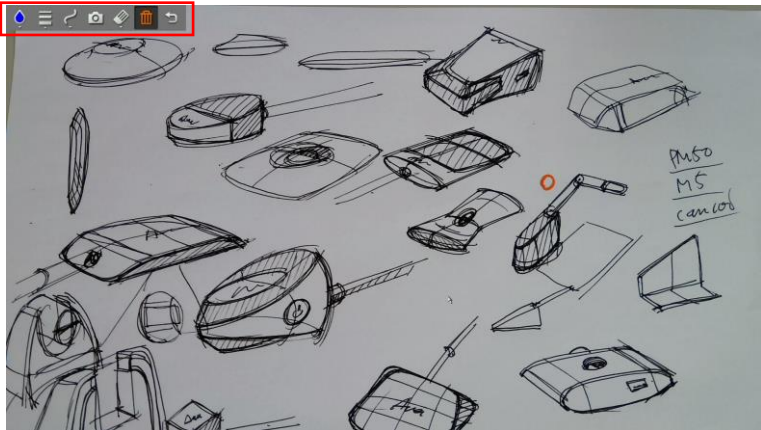







3. Am Live-Bildschirm rufen die Kommentarleiste mit einem Rechtsklick der Maus auf.



**Beschreibung der Kommentarleiste**



Taste	Funktion
 <span data-bbox="228 442 345 467">Farbpalette</span>	Auswahl der Linienfarbe. 
 <span data-bbox="228 545 345 569">Linienstärke</span>	Auswahl der Linienstärke. 
 <span data-bbox="228 636 271 660">Linie</span>	Wählen Sie gerade Linie, Freihand oder Schärfe zum Zeichnen. 
 <span data-bbox="228 756 313 781">Erfassen</span>	Erfassen des Bildes mit dem Kommentar und als neue Datei speichern.
 <span data-bbox="228 826 356 850">Radiergummi</span>	Damit löschen Sie Teile des Kommentars bzw. den gesamten Kommentar.
 <span data-bbox="228 892 313 916">Löschen</span>	Gesamten Kommentar am Bildschirm löschen.
 <span data-bbox="228 958 303 982">Zurück</span>	Kommentarleiste verlassen

## Bild-in-Bild Funktion

Auswahl Miniatur-Wiedergabebildschirm, Ort und Anzeige des Miniatur-Wiedergabebildschirms in der Ecke des Bildschirms, um das erfasste Bild im von der SD-Karte abzurufen.





1. Im Kameramodus halten Sie die Taste  3 Sekunden gedrückt, um das OSD-Menü aufzurufen.
2. Mit den Tasten  und  navigieren Sie zu **Präsentation** > **Bild-in-Bild**. Drücken Sie , um die Auswahl zu bestätigen.
3. Wählen Sie den Anzeigeort des Miniatur-Wiedergabebildschirm aus – **Oben links**, **Oben rechts**, **Unten links** oder **Unten rechts**. Bestätigen Sie die Auswahl mit .





BILD	Bild-in-Bild	Oben links
Präsentation	Bild-für-Bild	Oben rechts
Einstellungen	Anmerkung	Unten links
PLAYBACK		Rechts unten
SYSTEM		

4. Der folgenden bild-in-bild-Anzegebildschirm wird eingeblendet.

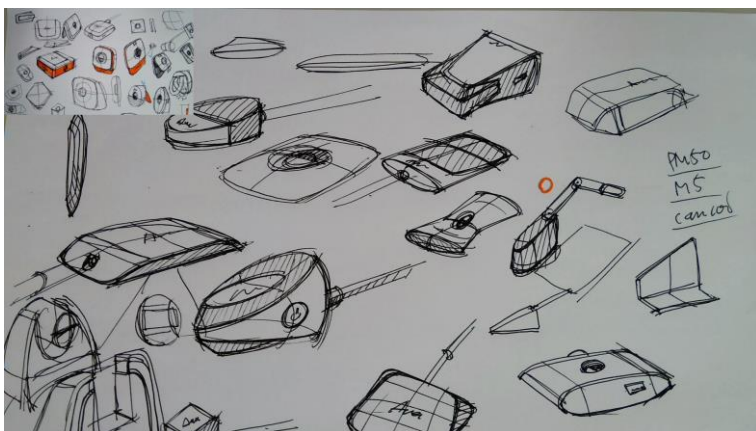



## Bild-für-Bild Funktion

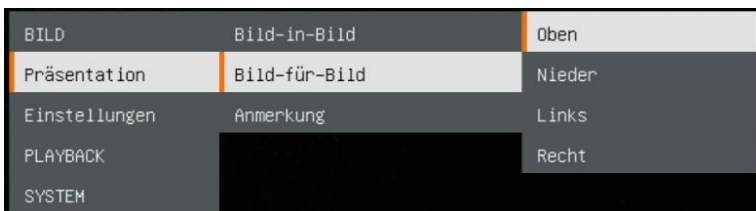

Wählen Sie den Ort des aufgenommenen Bildes und zeigen Sie das erfasste Bild auf dem Bildschirm an, um das erfasste Bild im von der SD-Karte abzurufen.

1. Im Kameramodus halten Sie die Taste  3 Sekunden gedrückt, um das OSD-Menü aufzurufen.
2. Mit den Tasten  und  navigieren Sie zu **Präsentation** > **Bild-für-Bild**. Drücken Sie , um die Auswahl zu bestätigen.
3. Wählen Sie den Anzeigeort des Miniatur-Wiedergabebildschirm aus – **Oben links**, **Oben rechts**, **Unten links** oder **Unten rechts**. Bestätigen Sie die Auswahl mit .

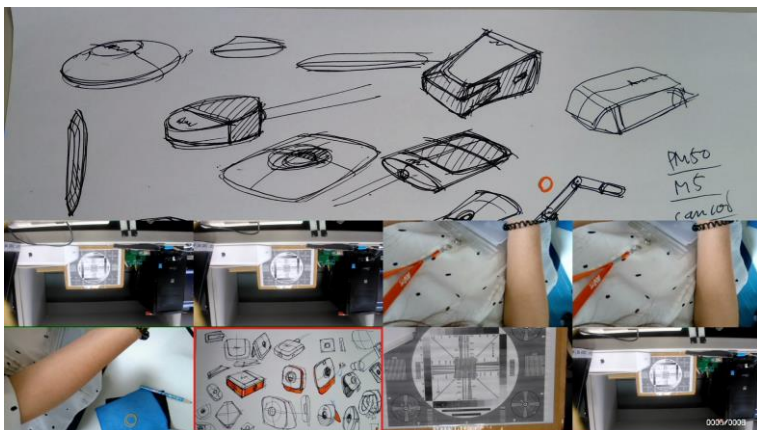

4. Mit  und der Taste  wählen Sie das erfasste Bild aus der Liste aus.



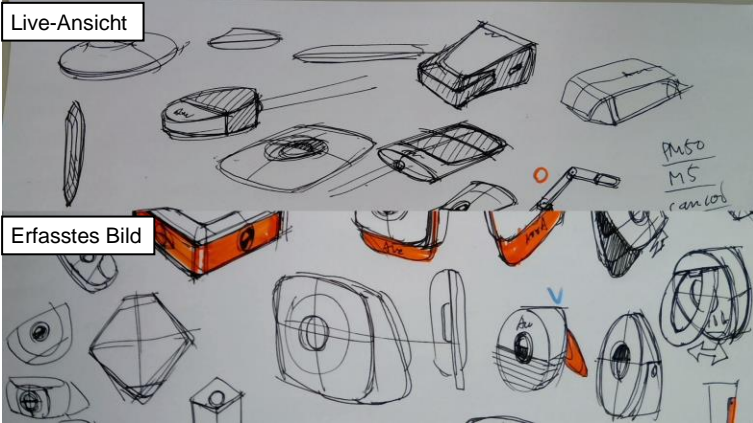

5. Der folgenden PBP-Anzeigebildschirm wird eingeblendet (Bild-für-Bild unten). Mit den Tasten  und  kann das erfasste Bild in der Ansicht nach oben oder unten verschoben werden.











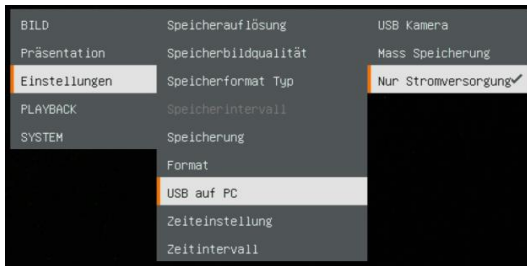



# Wiedergabemodus

Ansicht und Wiedergabe von erfassten Bildern und Videodateien.

## Schalten Sie in den Wiedergabemodus.





1. Im Kameramodus halten Sie die Taste  3 Sekunden gedrückt, um das OSD-Menü aufzurufen.
2. Navigieren Sie mit der Taste  und  zwischen **Einstellungen** > **USB auf PC** > **Nur Stromversorgung**.

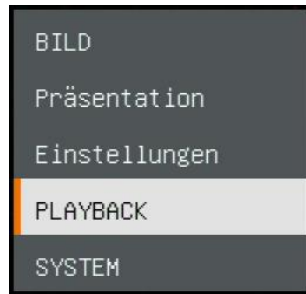













3. Mit den Tasten ,  und  navigieren Sie zur **Wiedergabe-Auswahl**
4. Drücken Sie dann , um die Auswahl zu bestätigen und erneut in den Wiedergabemodus umzuschalten.
5. Im Wiedergabemodus wählen Sie das Bild oder Video, das Sie ansehen möchten, mit den Tasten  +  und  +  aus. Für die Videowiedergabe drücken Sie die Taste , um die Wiedergabe zu starten. Um die Wiedergabe zu unterbrechen, drücken Sie erneut die Taste . Drücken Sie , um die Wiedergabe zu fortzusetzen.



## OSD-Menütasten

Taste	Funktion
	Zurück zur letzten Menüebene
	Nach oben (Auswahlelement)
	Nach unten (Auswahlelement)
	Auswahl eingeben

## Wiedergabe-Menütasten

Taste	Funktion
 +   + 	<ul style="list-style-type: none"> <li>■ Bild/Videoauswahl</li> <li>■  + : Schnellvorlauf während der Videowiedergabe</li> <li>■  + : Schnelrücklauf während der Videowiedergabe</li> </ul>
	Bild vergrößern
	Bild verkleinern
	<ul style="list-style-type: none"> <li>■ Video abspielen</li> <li>■ Gedrückt halten, um das Video während der Wiedergabe zu unterbrechen.</li> </ul>
	Videowiedergabe stoppen

## Bild

Automatische Wiedergabe aller erfassten Bilder und aufgezeichneten Videos. Allerdings werden lediglich Videodateien angezeigt; die Videoinhalte werden nicht abgespielt.



## Intervall

Legen Sie das Intervall vor der Anzeige des nächsten Bildes fest. Die Länge kann mit bis zu 120 Sek. angegeben werden.

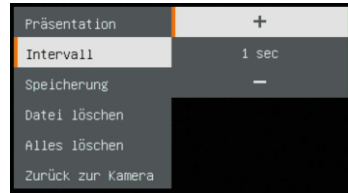

## Speicherung

Auswahl der Bild- und Videoquelle.



## Datei löschen

Ausgewähltes Bild oder Video dauerhaft löschen. Es wird eine Warnmeldung angezeigt. Mit **Ja** fahren Sie fort. Mit **Nein** brechen Sie den Löschvorgang ab.

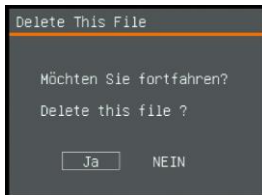

## Alle löschen

Dauerhaftes Löschen aller Daten in der gewählten Speicherquelle. Es wird eine Warnmeldung angezeigt. Mit **Ja** fahren Sie fort. Mit **Nein** brechen Sie den Löschvorgang ab.

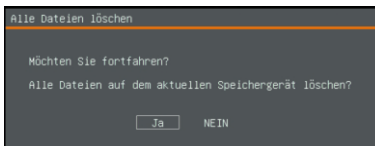



# Kommentieren

Während der Einzelbildanzeige können Sie eine gerade oder eine Freiformlinie über das erfasste Bild legen; dazu verwenden Sie die USB-Maus am USB-Anschluss der M11-8MV.

**[Hinweis]** Die Kommentarfunktion wird für die Videodatei nicht unterstützt

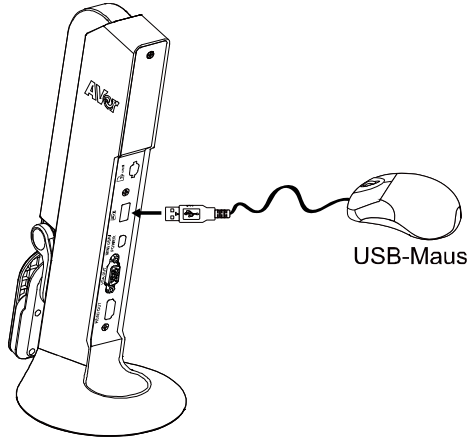
1. Verbinden Sie die Maus mit dem USB-Anschluss der M11-8MV.



2. Mit  rufen Sie das OSD-Menü auf.
3. Wählen Sie „**Wiedergabe**“.
4. Wählen Sie das Bild, dann wird die Wiedergabe-Symbolleiste angezeigt. Oder rufen Sie die Wiedergabe-Symbolleiste mit einem Rechtsklick der Maus auf.

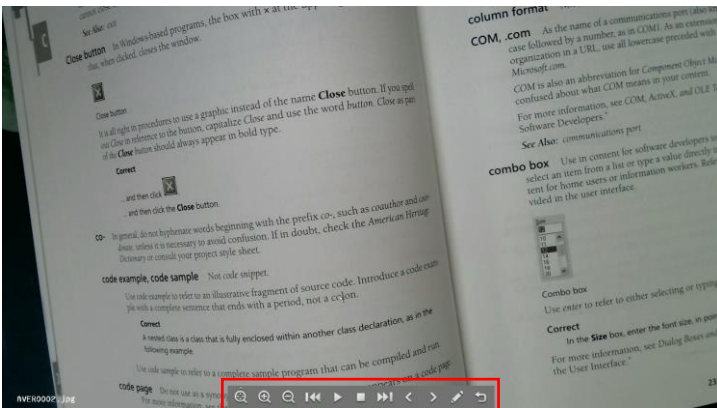

**Beschreibung der Wiedergabe-Symboleiste**



Taste	Funktion
	Das Bild nach links, rechts, oben oder unten bewegen Mit  erweitern Sie die Richtungstasten.
	
	Bild vergrößern
	Bild verkleinern
	Schnellrücklauf
	Videowiedergabe starten
	Videowiedergabe stoppen
	Schnellvorlauf
	Gehe zu vorheriges oder nächstes Bild/Datei
	Umschalten zur Kommentarfunktion.
	
	Zurück zur Bild- oder Dateiliste

5. Für das Umschalten in den Kommentarmodus  auf der Wiedergabe-Symbolleiste wählen.

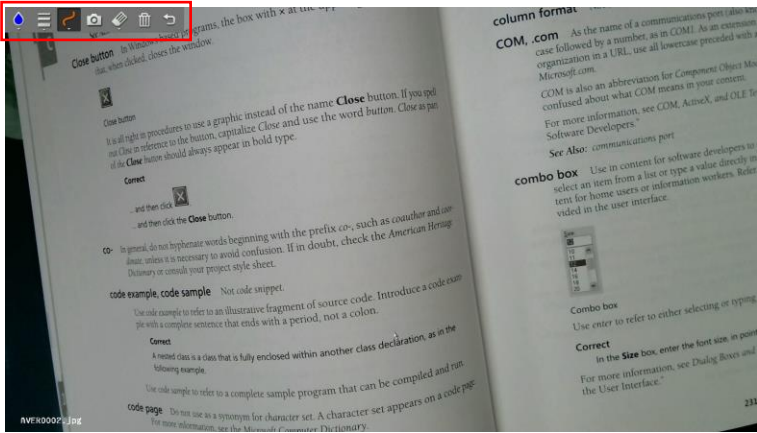

Taste	Funktion
 Farpalette	Auswahl der Linienfarbe. 
 Linienstärke	Auswahl der Linienstärke. 
 Linie	Wählen Sie gerade Linie, Freihand oder Schärfe zum Zeichnen. 
 Erfassen	Erfassen des Bildes mit dem Kommentar und als neue Datei speichern.
 Radiergummi	Damit löschen Sie Teile des Kommentars bzw. den gesamten Kommentar.
 Löschen	Gesamten Kommentar am Bildschirm löschen.
 Zurück	Zurück zur Wiedergabe-Symbolleiste

# So verwenden Sie die Kamera

## Kamerakopfwinkel

Bewegen Sie den Kamerakopf wie in der Abbildung gezeigt.

**[VORSICHT]** Halten Sie den Kamerakopf immer nur am Rand, wenn der Kamerakopf gedreht werde. Auf diese Weise wird die Beschädigung des Kamerakopfes vermieden.

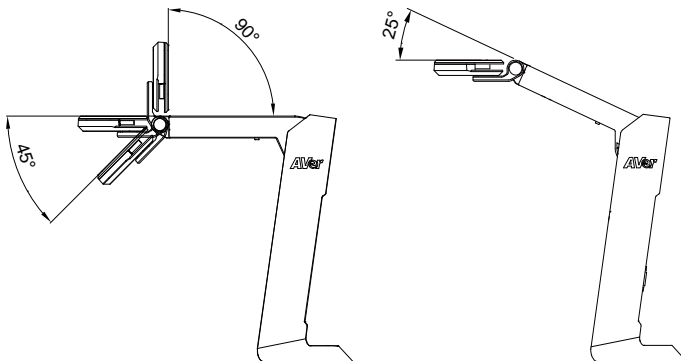
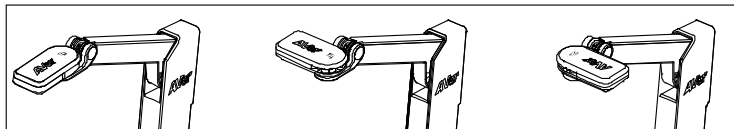

## Kameragehäusewinkel

**[VORSICHT]** Ziehen Sie den Arm **NIEMALS** über 107° hinaus, weil die Kamera sonst beschädigt wird.

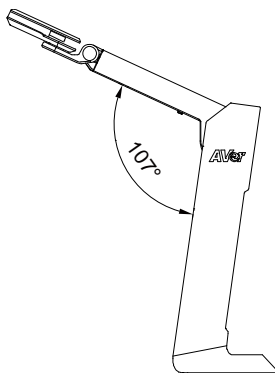

## Aufnahmebereich

Wenn die Kameraposition eine Höhe von 342,4 mm hat, ist der Aufnahmebereich die Größe A3.

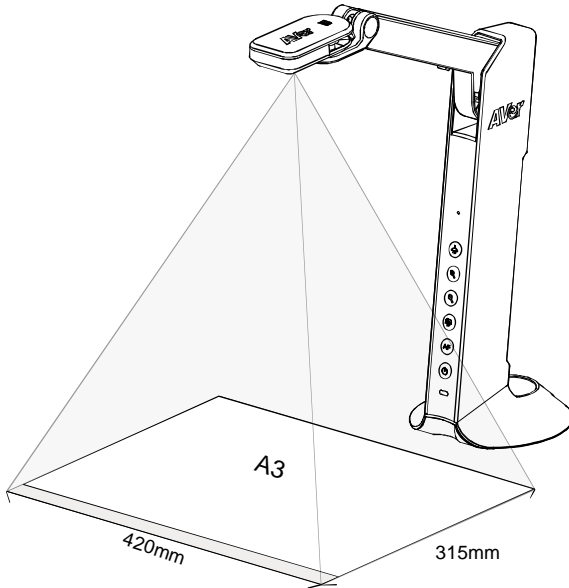
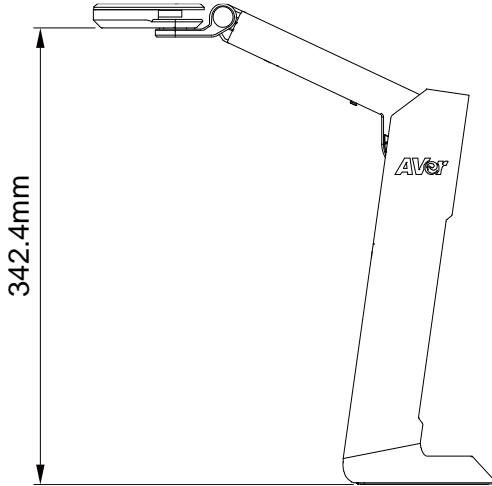

## Objektposition

Das Symbol oben auf der Kamera kann Sie bei der Platzierung von Objekten in einer positiven Richtung unterstützen.

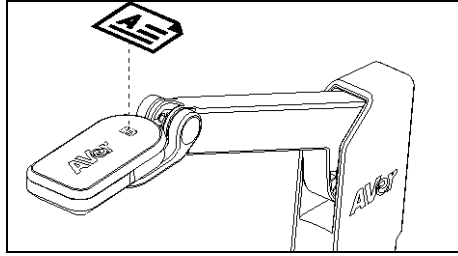

## Aufbewahrung der Kamera

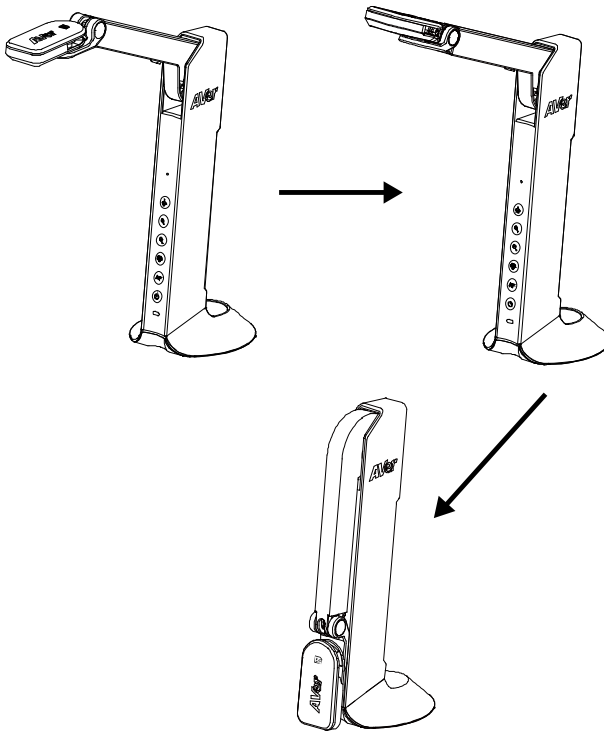

## Technische Daten

Sensor	1/3,06-Zoll-CMOS-Sensor
Pixel	8 MP
Bildrate	Max. 60 fps (Anzeige)
Bildmodus	Normal, Bewegung, Hohe Qualität
Effekt	Farbe/SW/Negativ
Fokussierung	Automatik/Manuell
Aufnahmebereich	A3 420 mm (H) x 315 mm (V)
Zoom	20-fach Digitalzoom
Stromquelle	Mini-USB ein, 5V/1A
Stromverbrauch	4,5 Watt (Lampe eingeschaltet) 4 Watt (Lampe ausgeschaltet)
USB Bus-Leistung	Ja, über Mini USB-Anschluss
Lampentyp	LED-Leuchte
USB	USB2.0 Typ-A x1 (< 5V/0.1 A, USB Flash-Laufwerk FAT32, 32 GB) USB Typ Mini-B x 1(Strom)
USB-Ausgang	3168 x 2376, 1920 x 1080, 1280 x 720, 1024 x 768, 800 x 600, 640 x 480
HDMI-Ausgang	1920 x 1080, 1280 x 720, 720 x 480
VGA-Ausgang	1920 x 1080, 1280 x 720, 720 x 480
Bilderfassung	120 Bilder (2 Megapixel)
Eingebautes Mikrofon	Ja
Micro SD-Kartenschlitz	FAT 32, 32 GB
Betrieb	360,4 mm(H)*116,7 mm (B)*303,4 mm (T)
Gefaltet	296,1 mm(H)*116,7 mm (B)*143,1 mm (T)
Nettogewicht	1.83 lbs(0.83 Kg)
Gewicht, brutto	2.87 lbs(1.301 Kg)
Software-Unterstützung	AVerTouch

## WARNUNG

- Zur Vermeidung der Brandgefahr bzw. von Elektroschocks setzen Sie das Gerät weder Regen noch Feuchtigkeit aus. Die Gewährleistung verfällt, wenn am Produkt unautorisierte Änderungen vorgenommen werden.
- Die Kamera keinen Schlägen oder starker Vibration aussetzen.
- Die richtige Stromspannung wählen, um Schäden an der Kamera zu vermeiden.
- Die Kamera muss so aufgestellt werden, dass niemand auf das Kabel treten kann, weil das Kabel eventuell ausfranst und die Drähte oder der Stecker beschädigt werden können.
- Um die Kamera zu bewegen, halten Sie sie mit beiden Händen an der Unterseite fest. Die Kamera nicht mithilfe von Objektiv oder flexiblem Arm bewegen.

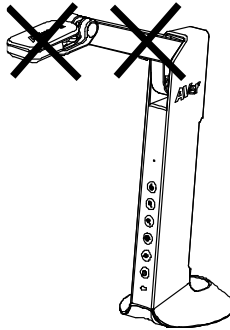

- Den mechanischen Arm und das Kamerateil nicht in die entgegengesetzte Richtung ziehen.

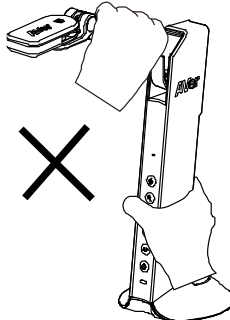

## **COPYRIGHT**

© 2021 AVer Information Inc. Alle Rechte vorbehalten.

## **HINWEIS**

DIE TECHNISCHEN DATEN UNTERLIEGEN ÄNDERUNGEN OHNE VORANKÜNDIGUNG. DIE ANGABEN IN DIESER UNTERLAGE DIENEN NUR ZUR INFORMATION.

## **WARENZEICHEN**

„AVer“ ist ein Warenzeichen von AVer Information Inc. Andere in diesem Dokument genannten Warenzeichen dienen lediglich der Information und sind Eigentum der entsprechenden Unternehmen.

## **VORSICHT**

Explosionsgefahr, wenn nicht der richtige Batterietyp verwendet wird. Entsorgen Sie gebrauchte Batterien entsprechend den Vorschriften.

## **Mehr Hilfe**

Für FAQs, technische Unterstützung, Software und für den Download der Bedienungsanleitung besuchen Sie bitte:

### **Europe:**

<https://www.avereurope.com/download-center/>

### **Technischer Support:**

<https://de.avereurope.com/technical-support>

## **Kontaktinformationen**

AVer Information Europe B.V.

Westblaak 134, 3012 KM, Rotterdam, The Netherlands

Tel: +31 (0) 10 7600 550

## Contenu de L'emballage

Les éléments ci-dessous sont fournis avec ce produit. Si un élément venait à manquer, adressez-vous au revendeur auquel vous avez acheté le produit.

Unité M11-8MV

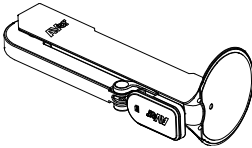

Câble USB

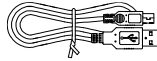

Carte code QR



Carte de garantie\*



\* Europe, Japan, Taiwan seulement

## Accessoires En Option

Sacoche de transport



Film antireflet

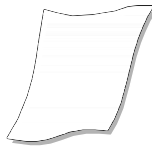



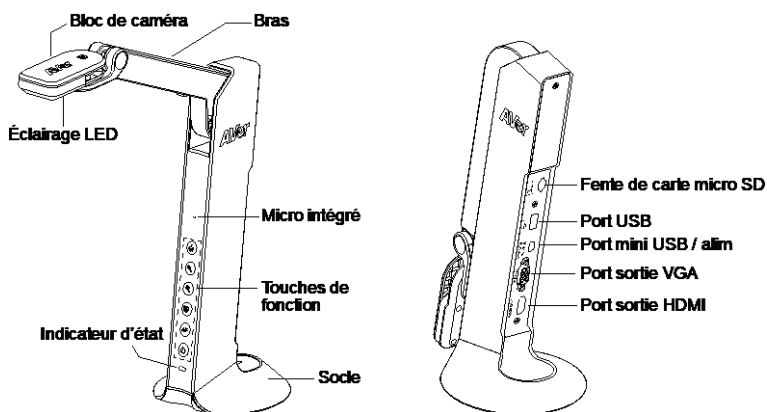



# Présentation







## Fonctions des touches

### Panneau de commande





Touche	Fonction
	<ul style="list-style-type: none"> <li>■ Lampe marche/arrêt</li> <li>■ Appuyez et maintenez 3 secondes pour faire apparaître le menu OSD.</li> </ul>
	Zoom avant
	Zoom arrière
	<ul style="list-style-type: none"> <li>■ Rotation 0 / 180°</li> <li>■ Appuyez et maintenez 3 secondes pour figer l'écran. Débloquez en appuyant et en maintenant à nouveau 3 secondes.</li> </ul>
	<ul style="list-style-type: none"> <li>■ Mise au point automatique</li> <li>■ Appuyez et maintenez 3 secondes pour démarrer l'enregistrement.</li> <li>Arrêtez l'enregistrement en appuyant et en maintenant à nouveau  3 secondes.</li> </ul>
	Tension marche / arrêt

## Mode OSD

Touche	Fonction
	<ul style="list-style-type: none"><li>■ Retour à la dernière page du niveau de menu</li><li>■ Quitter le menu OSD</li></ul>
	Haut (sélection d'élément)
	Bas (sélection d'élément)
	Entrer sélection

## Touches composées

Appuyez sur les touches pour utiliser la fonction des touches composées.

Touche	Fonction
 + 	Retour aux paramètres d'usine par défaut.
 + 	Capture d'image

[Remarque] Pour Enregistrement et Capture, veuillez passer en mode Alimentation uniquement (**Puissance**).

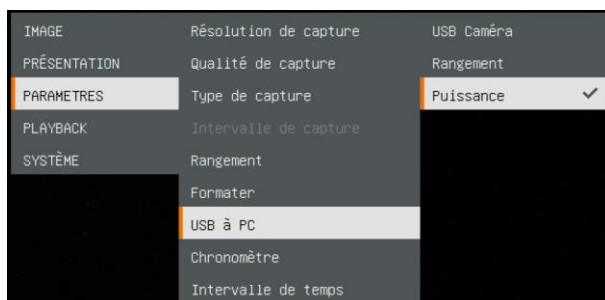

## Indicateur LED

Tension	
	<b>Vert fixe</b> : Mise en marche <b>Rouge fixe</b> : Veille <b>Rouge clignotant</b> : La caméra est en cours de démarrage

# Connexion de l'appareil

## Branchement d'alimentation à une prise murale

1

Brancher l'alimentation au secteur et allumer le M11-8MV.

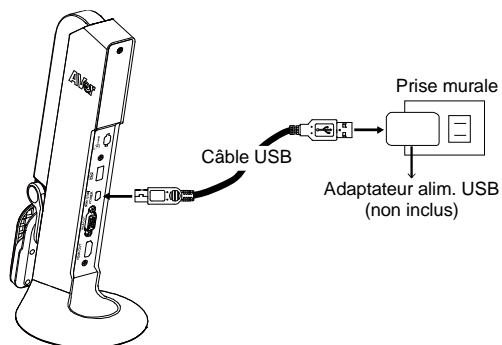

### [Remarque]

- Branchez le câble USB livré du mini port USB / Alimentation du M11-8MV avec l'adaptateur secteur USB (non livré) à la prise murale.
- L'utilisateur doit acheter un adaptateur d'alimentation USB 5V / 1A (non livré) pour connecter le câble USB à la prise murale.
- Au démarrage de la caméra, le voyant d'alimentation clignote en rouge.

## Connexion d'alimentation au PC / ordinateur portable

- 1 Connectez au port USB du PC / ordinateur portable pour l'alimentation.

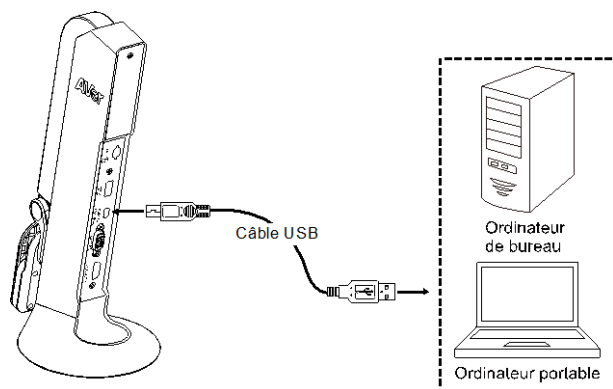

### [Remarque]

- Branchez le câble USB livré du mini port USB / d'alimentation du M11-8MV à l'ordinateur portable / PC.
- Au démarrage de la caméra, le voyant d'alimentation clignote en rouge.
- La puissance USB requise pour M11-8MV est USB 5V / 1A.
- Pour les fonctions de stockage, formatage, capture, enregistrement et lecture, veuillez passer en mode Alimentation uniquement (Puissance)

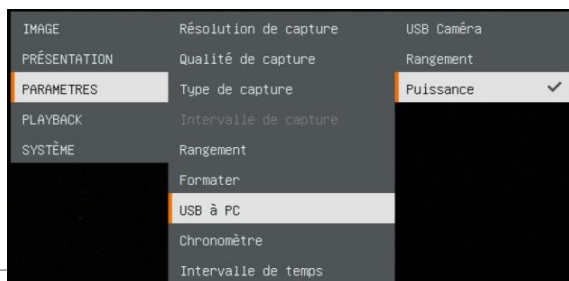

## Connexion HDMI

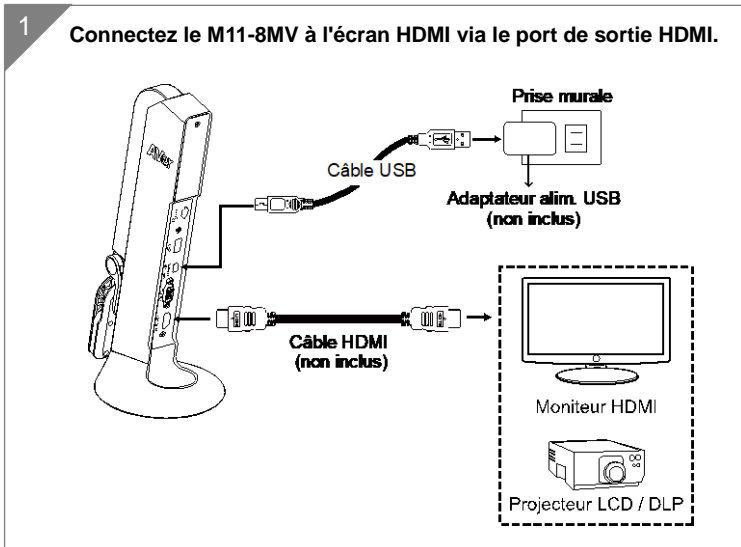

## Connexion VGA

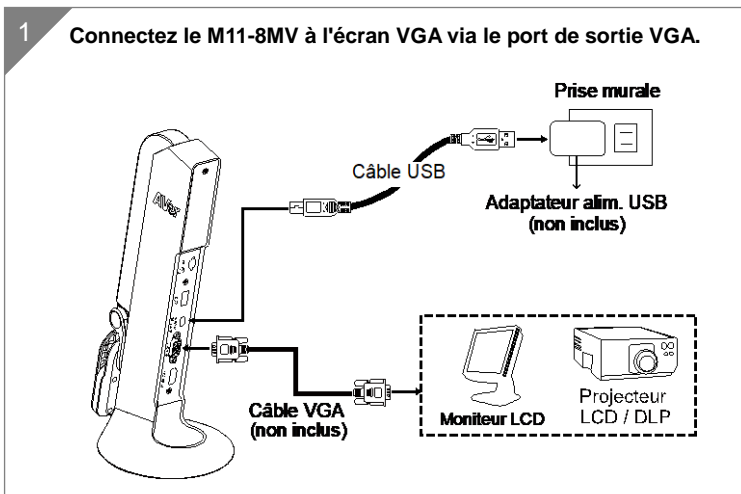

## Connexion USB

- 1 Connectez la clé USB au port USB pour sauvegarder le fichier de capture et d'enregistrement.

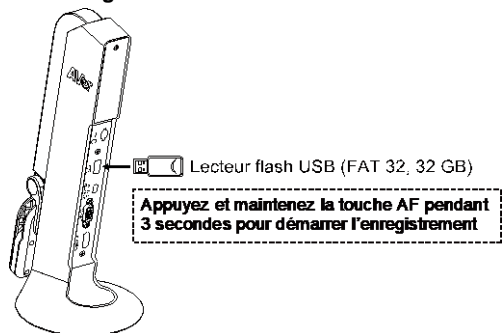

[Remarque] La clé USB prise en charge est de 32 G (FAT32) au maximum.

## Insérez une carte micro SD.

- 1 Insérez la carte dans la fente de la carte Micro SD

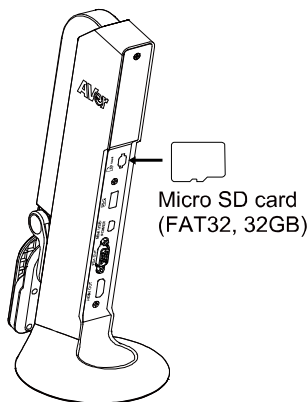

### [Remarque]

- La carte Micro SD peut stocker des fichiers d'images de capture et d'enregistrement.
- La capacité maximale de la carte micro SD prise en charge est de 32 G (FAT32).

# Faire fonctionner la caméra avec AVerTouch

1

Connectez la caméra au PC / ordinateur portable et installez l'application AVerTouch.

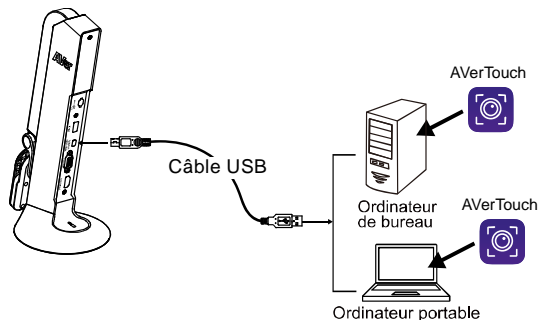

## [Remarque]

- Téléchargez l'application AVerTouch sur : <https://www.aver.com/download-center/>
- Réglez la caméra en mode USB. Accédez au menu **OSD > Paramètres > USB à PC > USB Caméra**.

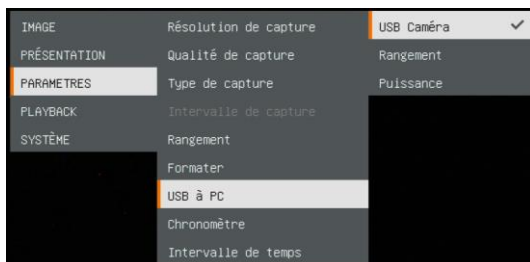

2

Ouvrez l'application AVerTouch, cliquez sur  pour connecter la caméra.

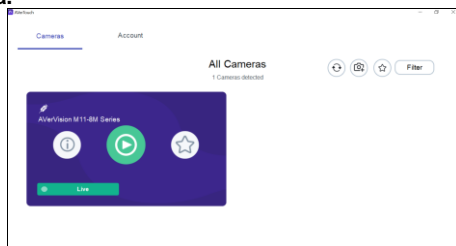

## Mode présentation (temps réel)

[Remarque] Avant d'utiliser les fonctions d'annotation ou PIP/PBP du mode Présentation, définissez d'abord sur la caméra le mode Alimentation seulement. Allez à Menu **OSD > PARAMÈTRES > USB à PC > Puissance**.

### Annotation

En mode image unique temps réel (aperçu), l'utilisateur peut utiliser la fonction d'annotation pour superposer une ligne droite ou une ligne de forme libre sur l'image capturée grâce à la souris USB connectée au port USB du M11-8MV.

1. Connectez la souris au port USB du M11-8MV.

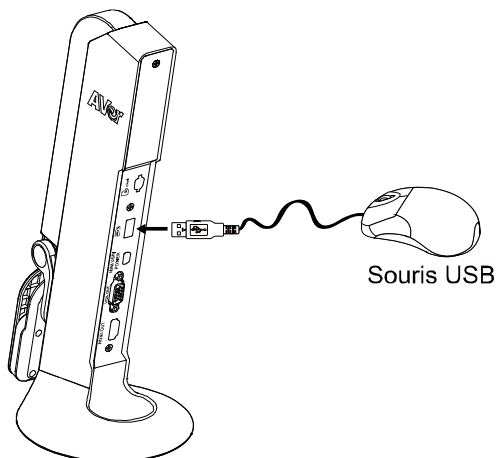

2. Allez à Menu **OSD > PRÉSENTATION > Annotation**.

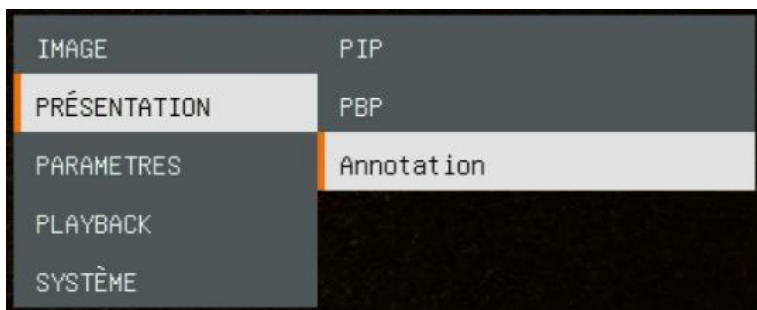



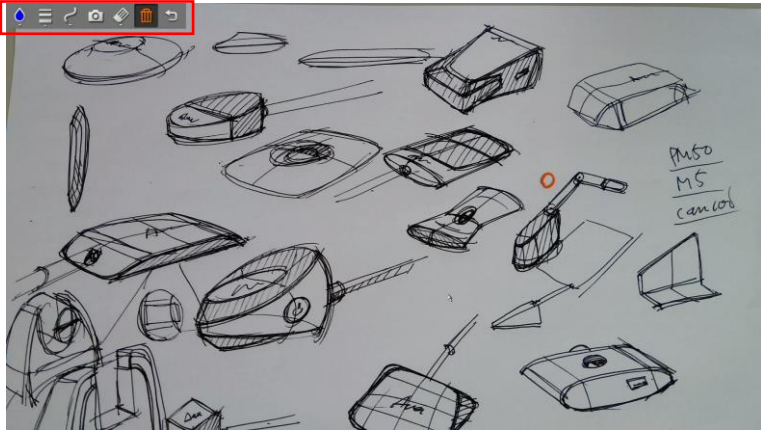







3. Dans l'écran en direct, cliquez avec le bouton droit de la souris pour afficher la barre d'annotation.



## Description de la barre d'annotation



Bouton	Fonction
 Palette de couleurs	Sélectionnez la couleur de ligne. 
 Épaisseur de ligne	Sélectionnez l'épaisseur de ligne. 
 Ligne	Sélectionnez la ligne droite, la main levée ou nette à dessiner. 
 Capture	Capturez l'image avec l'annotation et enregistrez-la en tant que nouveau fichier.
 Effacer	Sélectionnez pour effacer toute partie de l'annotation avec laquelle elle entre en contact ou supprimer toute l'annotation.
 Supprimer	Suppression de toute annotation à l'écran.
 Retour	Quittez la barre d'annotation.

## Fonction PIP

Sélectionnez l'emplacement de l'écran de lecture des images miniatures et affichez l'écran de lecture de celles-ci à l'angle de l'écran pour rappeler l'image capturée depuis la carte SD.





1. En mode caméra, appuyez et maintenez  la touche 3 secondes pour faire apparaître le menu OSD.
2. Utilisez , et la touche  pour passer à **Presentation > PIP**. Appuyez sur  pour valider la sélection.
3. Sélectionnez le lieu d'affichage de l'écran de lecture des miniatures - **Upper Left, Upper Right, Lower Left, ou Lower Right** (en haut à gauche, en haut à droite, en bas à gauche, en bas à droite) Appuyez sur  pour confirmer la sélection.





IMAGE	PIP	En haut à gauche
PRÉSENTATION	PBP	En haut à droite
PARAMETRES	Annotation	En bas à gauche
PLAYBACK		En bas à droite
SYSTÈME		

4. L'écran PIP affiche comme indiqué ci-dessous.

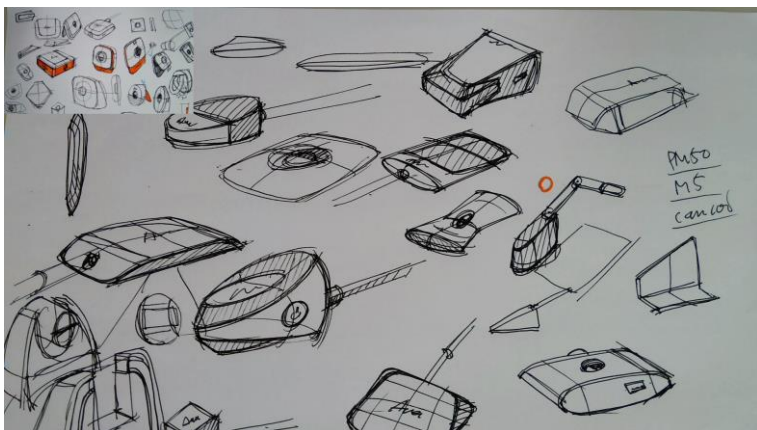

## Fonction PBP

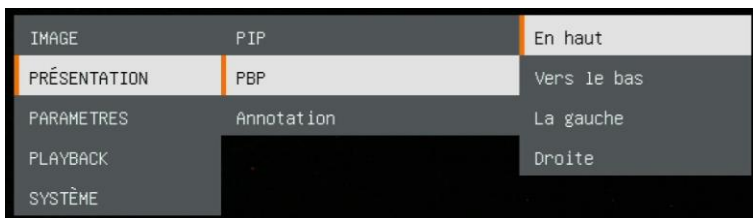

Sélectionnez l'emplacement de l'image capturée et affichez l'image capturée à l'écran pour rappeler celle-ci depuis la carte SD.

1. En mode caméra, appuyez et maintenez  la touche 3 secondes pour faire apparaître le menu OSD.
2. Utilisez , et la touche  pour passer à **Présentation > PBP**.  
Appuyez sur  Pour valider la sélection.
3. Sélectionnez le lieu d'affichage de l'écran de lecture des miniatures - **Upper Left, Upper Right, Lower Left, ou Lower Right** (en haut à gauche, en haut à droite, en bas à gauche, en bas à droite) Appuyez sur  pour confirmer la sélection.

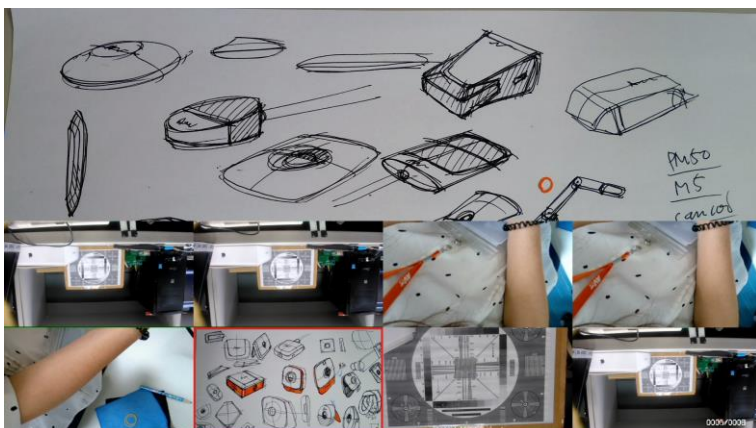

4. Utilisez les touches  et  pour sélectionner l'image capturée de la liste.



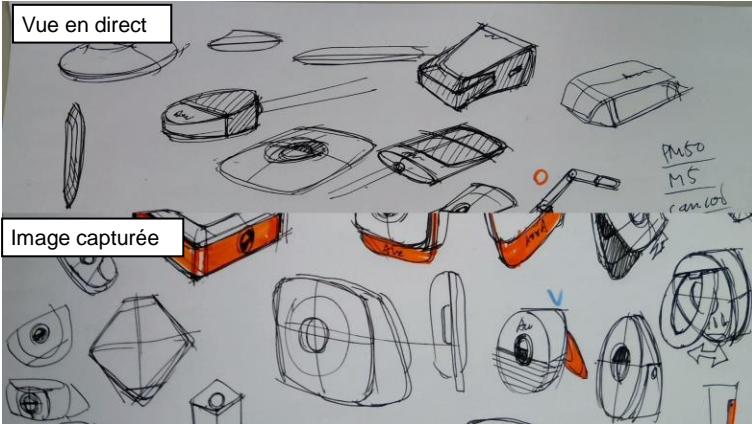

5. L'écran d'affichage PBP comme indiqué ci-dessous (PBP est en position basse). En utilisant les touches  et , il est possible de déplacer l'image capturée vers le haut ou le bas pour la visualiser.











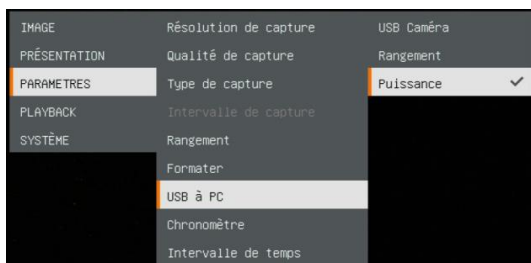

# Mode de lecture

Affichez les images de capture et les fichiers d'enregistrement.

## Passez en mode de lecture





1. En mode caméra, appuyez et maintenez  la touche 3 secondes pour faire apparaître le menu OSD.
2. Utilisez  et déplacez la touche  vers **Paramètres > USB à PC > Puissance**.

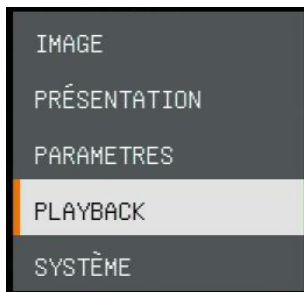









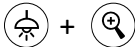
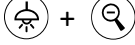

3. Utilisez , , et la touche  pour passer à la sélection de lecture (**Playback**).
4. Ensuite, appuyez sur  confirmez la sélection et passez en mode de lecture.
5. En mode lecture, utilisez les touches  +  et  + pour sélectionner l'image ou la vidéo à afficher manuellement. Pour regarder une vidéo, appuyez sur la touche  pour lancer la lecture. Pour interrompre la lecture, appuyez de nouveau sur la touche . Appuyez sur  pour arrêter la lecture.



## Touches de menu OSD

Touche	Fonction
	Retour à la dernière page du niveau de menu
	Haut (sélection d'élément)
	Bas (sélection d'élément)
	Entrer sélection

## Touches du menu lecture

Touche	Fonction
	<ul style="list-style-type: none"> <li>■ Sélection image / vidéo</li> </ul>
	<ul style="list-style-type: none"> <li>■  +  : Lecture rapide en avant pendant lecture vidéo</li> </ul>
	<ul style="list-style-type: none"> <li>■  +  : Rembobinage rapide pendant la lecture de la vidéo</li> </ul>
	Zoom avant sur image
	Zoom arrière sur image
	<ul style="list-style-type: none"> <li>■ Lecture vidéo</li> <li>■ Appuyez et maintenez pour faire une pause pendant la lecture de la vidéo</li> </ul>
	Arrêtez la lecture de la vidéo

## Diaporama

Pour lire automatiquement toutes les images de capture et les vidéos enregistrées; mais les vidéos affichent uniquement des fichiers et ne lisent pas le contenu vidéo.

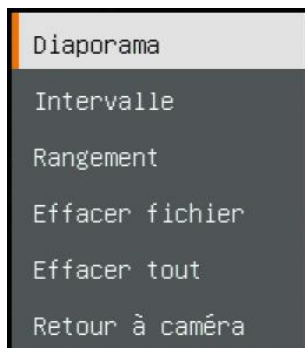

## Intervalle

Réglez l'intervalle de temps avant l'affichage de l'image suivante. La durée peut être réglée jusqu'à 120 secondes.

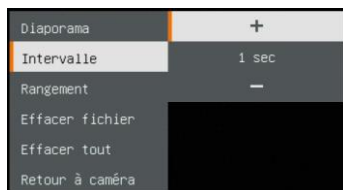

## Rangement

Sélectionnez la source des images et des vidéos.

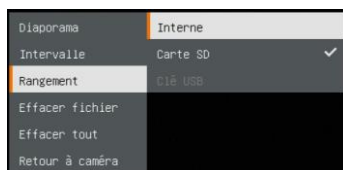

## Effacer fichier

Supprimez définitivement l'image ou la vidéo sélectionnée. Un message d'avertissement apparaîtra. Sélectionnez **Yes** pour continuer et **No** pour annuler la suppression.

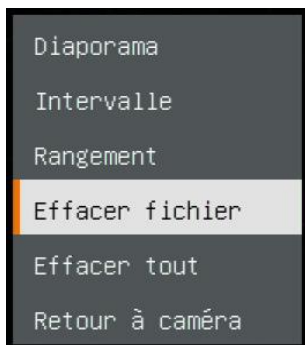
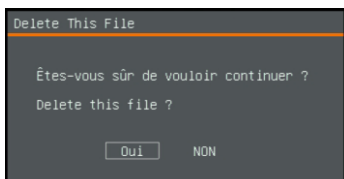

## Effacer tout

Supprimez définitivement toutes les données de la source de mémoire sélectionnée. Un message d'avertissement apparaîtra. Sélectionnez **Yes** pour continuer et **No** pour annuler la suppression.

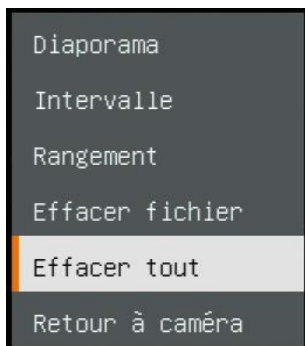
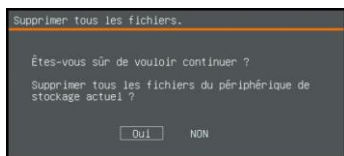

## Annotation

En mode de lecture d'image unique, l'utilisateur peut utiliser la fonction d'annotation pour superposer une ligne droite ou une ligne de forme libre sur l'image capturée grâce à la souris USB connectée au port USB du M11-8MV. **[Remarque]** La fonction d'annotation ne prend pas en charge le fichier vidéo.

1. Connectez la souris au port USB du M11-8MV.

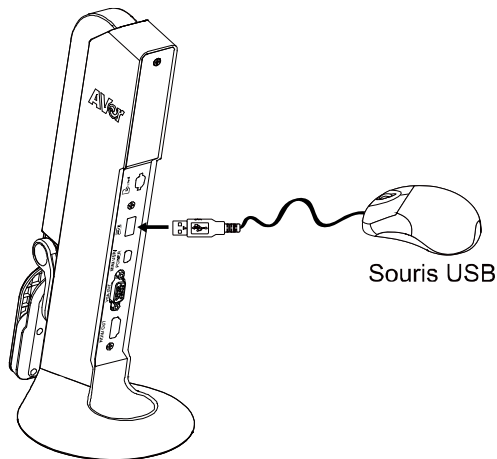

2. Appuyez sur  pour appeler le menu OSD.
3. Sélectionnez «**Playback**».
4. Sélectionnez l'image et la barre d'outils de lecture s'affiche. Ou cliquez avec le bouton droit de la souris pour appeler la barre d'outils de lecture.

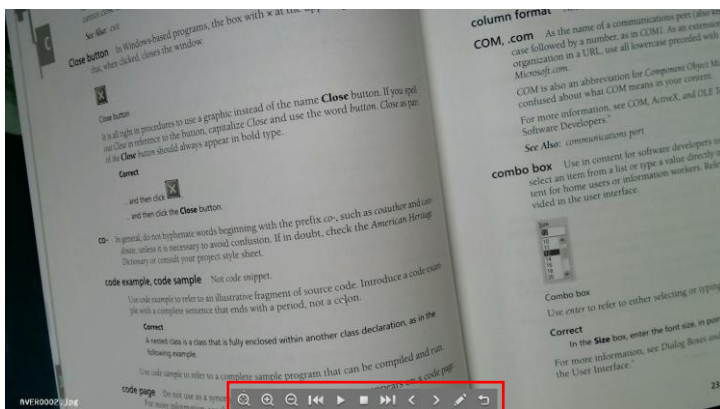









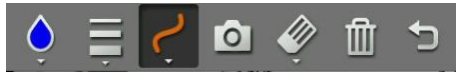
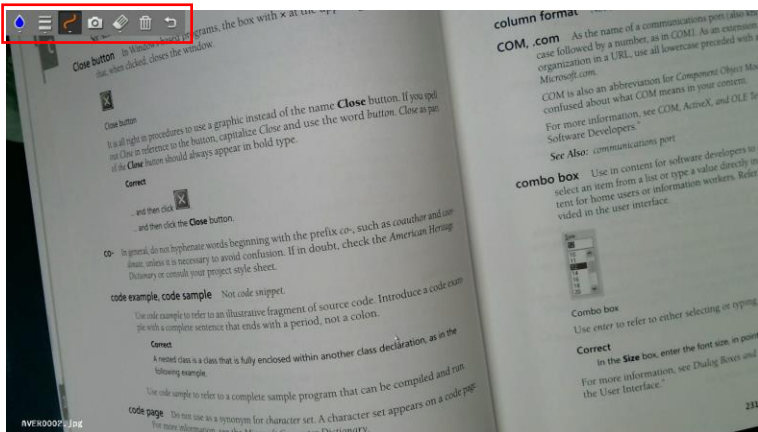

## Description de la barre d'outils de lecture



Bouton	Fonction
	Déplacez l'image vers la gauche, la droite, le haut et le bas. Sélectionnez  pour développer les boutons de direction. 
	Zoom avant sur image
	Zoom arrière sur image
	Rembobinage rapide
	Démarrez la lecture de la vidéo
	Arrêtez la lecture de la vidéo
	Avance rapide
	Aller à la prochaine ou dernière image ou fichier
	Passez à la fonction d'annotation. 
	Retour à la liste d'images ou de fichiers

5. Pour passer en mode d'annotation, sélectionnez  dans la barre d'outils de lecture.



Bouton	Function
 Palette de couleurs	Sélectionnez la couleur de ligne. 
 Épaisseur de ligne	Sélectionnez l'épaisseur de ligne. 
 Ligne	Sélectionnez la ligne droite, la main levée ou nette à dessiner. 
 Capture	Capturez l'image avec l'annotation et enregistrez-la en tant que nouveau fichier.
 Effacer	Sélectionnez pour effacer toute partie de l'annotation avec laquelle elle entre en contact ou supprimer toute l'annotation.
 Supprimer	Suppression de toute annotation à l'écran.
 Retour	Retour à la barre d'outils de lecture.

# Utilisation de la caméra

## Angle de bloc de caméra

Déplacez le bloc de caméra comme illustré.

**[ATTENTION]** Pour éviter d'endommager le bloc de caméra, maintenez le bord du bloc pour faire pivoter celui-ci.

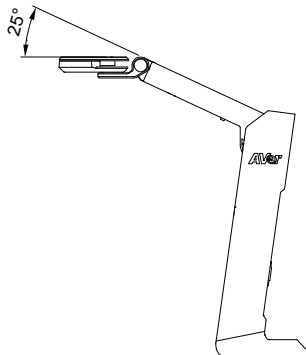
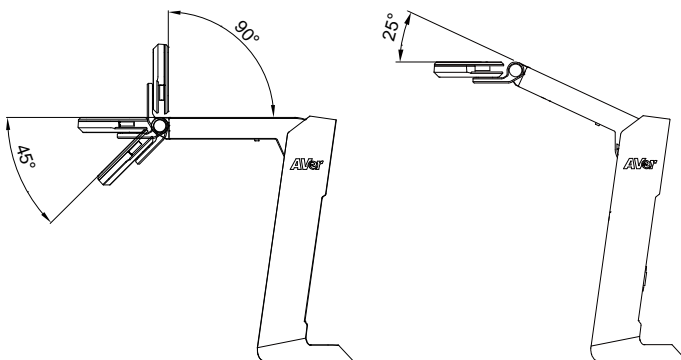
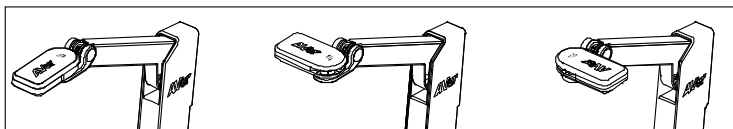

## Angle de corps de caméra

**[ATTENTION]** Pour éviter d'endommager la caméra, NE PAS ouvrir l'angle du bras au-dessus 107°.

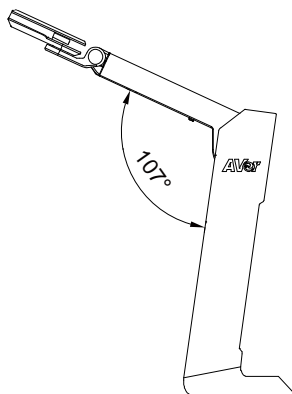

## Champ de vision

Lorsque la caméra est en position haute de 342,4 mm, la zone de prise de vue sera de format A3.

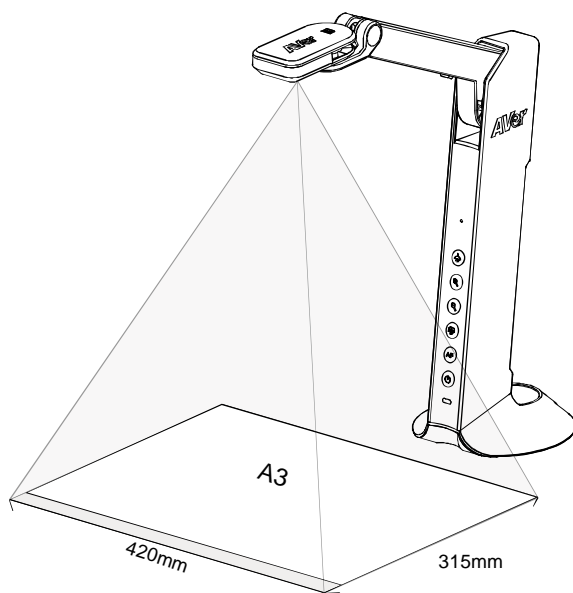
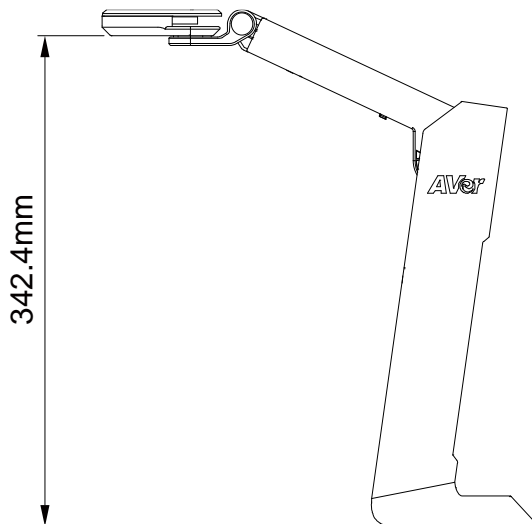

## Position de l'objet

L'icône sur le dessus du bloc de caméra sert à placer des objets dans une direction positive.

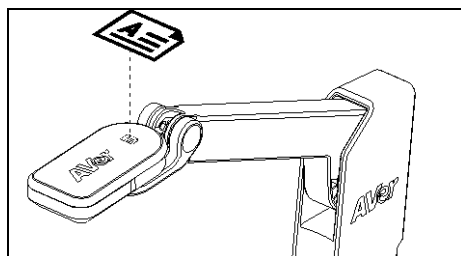

## Rangement de la caméra

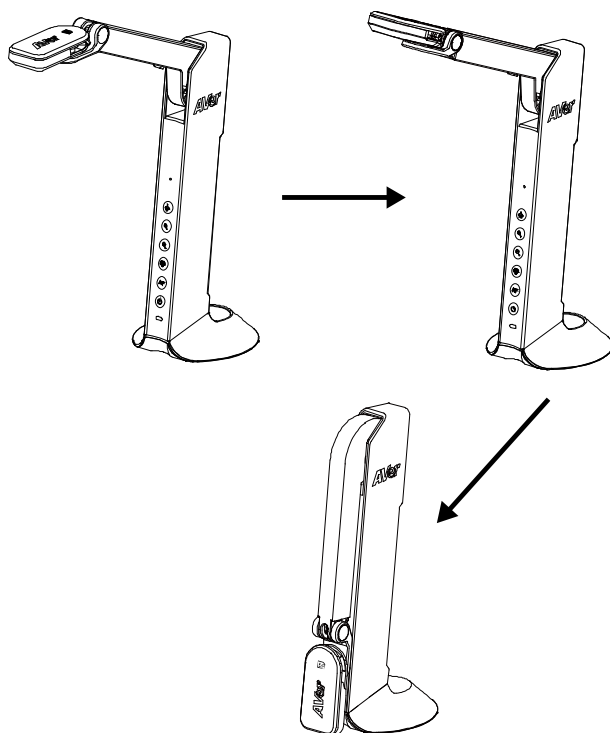

## Caractéristiques

Capteur	1/3.06 po Capteur CMOS
Nombre de pixels	8 MP
Cadence d'images	Max. 60 fps (affichage)
Mode image	Normal / mouvement / haute qualité
Effet	Couleur / N&B / négatif
Focalisation	Auto / manuel
Zone de prise de vue	A3, 420 mm (H) * 315 mm (V)
Niveau de zoom	Zoom numérique 20 X
Source d'alimentation	Mini-USB in, 5 V / 1 A
Consommation	4,5 W (lampe allumée) 4 W (lampe éteinte)
Alimentation par bus USB	Oui, via mini port USB
Type de lampe	Éclairage LED
USB	USB2.0 Type-A x1 (< 5V/0.1A, USB flash drive FAT32, 32GB) USB type mini-B x 1 (alimentation)
Sortie USB	3168 x 2376, 1920 x 1080, 1280 x 720, 1024 x 768, 800 x 600, 640 x 480
Sortie HDMI	1920 x 1080, 1280 x 720, 720 x 480
Sortie VGA	1920 x 1080, 1280 x 720, 720 x 480
Capture d'image	120 images (2 mégapixels)
Micro intégré	Oui
Emplacement pour carte micro SD	FAT 32, 32 GB
En fonctionnement.	360,4 mm (H) x 116,7 mm (L) x 303,4 mm (P)
Plié	296,1 mm (H) x 116,7 mm (L) x 143,1 mm (P)
Poids net	1.83 lbs(0.83 Kg)
Poids brut	2.87 lbs(1.301 Kg)
Support logiciel	AVerTouch

## AVERTISSEMENT

- Ne laissez pas tomber l'appareil ni ne lui faites subir de heurts.
- Pour éviter d'endommager l'appareil, utilisez la tension d'alimentation correcte.
- Ne placez pas l'appareil de manière à ce que l'on puisse marcher sur le cordon d'alimentation, car cela pourrait provoquer son effilochage ou endommager la prise.
- Ne tirez pas sur le bras mécanique et sur l'appareil dans des directions opposées.
- Pour réduire les risques d'incendie ou de décharges électriques, n'exposez pas cet appareil à la pluie ni à l'humidité. Toute modification non autorisée du produit annulera la garantie.
- Pour déplacer l'appareil, tenez-le par le dessous avec les deux mains. Ne déplacez pas l'appareil en le tenant par l'objectif ou par le bras souple.

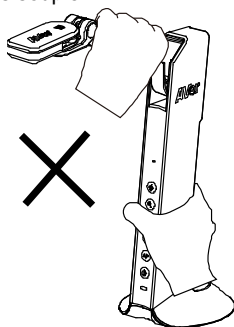
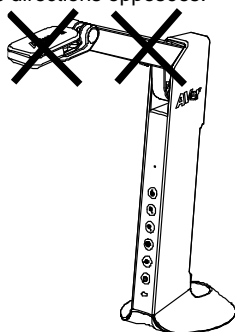

## COPYRIGHT

©2024 AVer Information Inc. Tous droits réservés.

## REMARQUES

LES CARACTÉRISTIQUES SONT SUSCEPTIBLES DE MODIFICATIONS SANS AVIS PRÉALABLE. LES INFORMATIONS CONTENUES DANS LE PRÉSENT DOCUMENT DOIVENT ÊTRE CONSIDÉRÉES COMME N'AYANT QU'UNE VALEUR DE RÉFÉRENCE.

## MARQUES COMMERCIALES

« AVer » est une marque commerciale propriété d'AVer Information Inc. Les autres marques commerciales mentionnées dans ce document à seule fin descriptive appartiennent à leurs sociétés respectives.

## ATTENTION

Risque d'explosion si la batterie est remplacée par une autre de type incorrect. La mise au rebut des batteries usagées doit se faire selon les instructions.

## **Aide Supplémentaire**

Pour la FAQ, l'assistance technique et le téléchargement du logiciel et du mode d'emploi, rendez-vous sur le site :

**Siège européen:**

<https://www.avereurope.com/download-center/>

**Support Technique :**

<https://fr.avereurope.com/technical-support>

## **Coordonnées de contact**

AVer Information Europe B.V.

Westblaak 134, 3012 KM, Rotterdam, The Netherlands

Tel: +31 (0) 10 7600 550

## Contenido Del Paquete

Este producto incluye los elementos siguientes. Si falta algún elemento, póngase en contacto con el distribuidor al que adquirió el producto.

Unidad M11-8MV

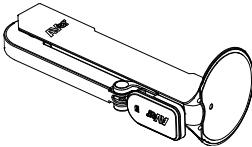

Cable USB

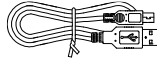

Tarjeta con código QR



Tarjeta de garantía\*



\* Solo para Europa, Japan, Taiwan

## Accesorios Opcionales

Bolsa de transporte



Lámina antirreflectante





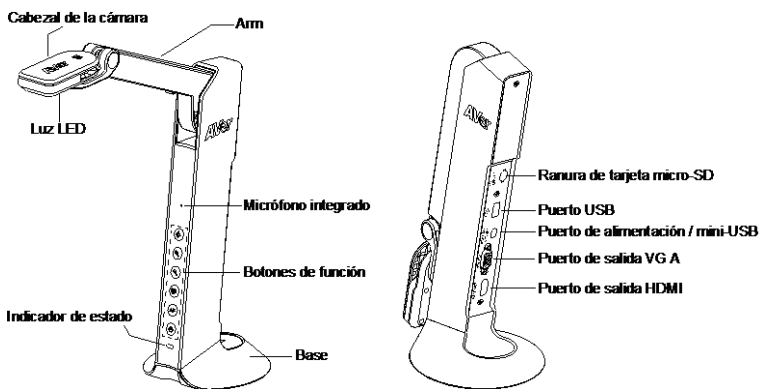



# Información general





# Botones de función

## Panel de control

Botón	Función
	<ul style="list-style-type: none"><li>■ Encender/Apagar la luz</li><li>■ Mantenga pulsado este botón durante tres segundos para acceder al menú OSD.</li></ul>
	Acercar
	Alejar
	<ul style="list-style-type: none"><li>■ Girar 0/180°</li><li>■ Mantenga pulsado este botón durante tres segundos para congelar la pantalla. Para descongelarla, mantenga pulsado de nuevo el botón durante tres segundos.</li></ul>
	<ul style="list-style-type: none"><li>■ Enfoque automático</li><li>■ Mantenga pulsado este botón durante tres segundos para iniciar la grabación</li></ul> <p>Para detenerla, mantenga pulsado de nuevo  durante tres segundos.</p>
	Apagar/Encender la unidad

## Modo OSD

Botón	Función
	<ul style="list-style-type: none"><li>■ Vuelva a la última página del nivel de menú</li><li>■ Salga del menú OSD</li></ul>
	Arriba (opción de selección)
	Abajo (opción de selección)
	Confirmar selección

## Combinaciones de botones

Combine los siguientes botones:

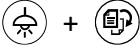
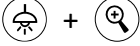
Botón	Función
	Restablezca los ajustes predeterminados de fábrica.
	Capture una imagen.

[Nota] Para **grabar** y **capturar**, cambie al modo «Solo poder».

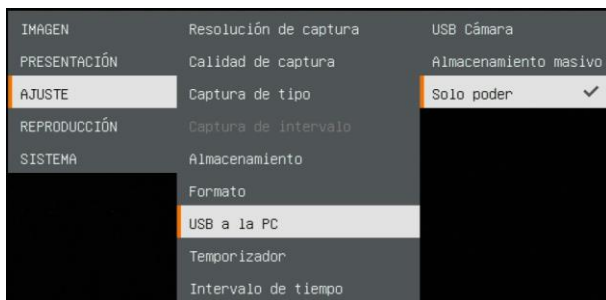

## Indicador LED

	<b>Verde fijo:</b> encendido <b>Rojo fijo:</b> en espera <b>Rojo intermitente:</b> la cámara se está iniciando
---	--

# Conexión de dispositivos

## Conexión a la toma de corriente

1

Conecte la alimentación y encienda el M11-8MV.

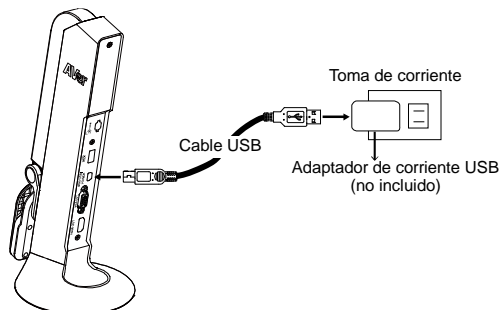

### [Nota]

- El cable USB incluido en el paquete permite conectar el puerto mini-USB / de alimentación del M11-8MV a la toma de corriente mediante un adaptador de corriente USB (no incluido).
- El usuario debe comprar un adaptador de corriente USB de 5 V y 1 A (no incluido) para conectar el cable USB a una toma de corriente.
- Cuando se ponga en marcha la cámara, el indicador de alimentación parpadeará en rojo.

## Conexión a un PC/portátil

- 1 Conecte la unidad al puerto USB de un PC/portátil para fines de alimentación.

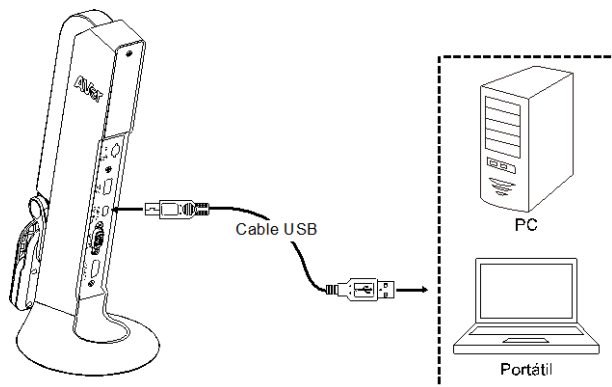

### [Nota]

- El cable USB incluido en el paquete permite conectar el puerto mini-USB / de alimentación del M11-8MV a un PC/portátil.
- Cuando se ponga en marcha la cámara, el indicador de alimentación parpadeará en rojo.
- Requisitos de la alimentación USB del M11-8MV: 5 V y 1 A.
- Para las funciones de almacenamiento, formateo, captura, grabación y reproducción, consulte el modo «Solo poder».

IMAGEN	Resolución de captura	USB Cámara
PRESENTACIÓN	Calidad de captura	Almacenamiento masivo
AJUSTE	Captura de tipo	Solo poder ✓
REPRODUCCIÓN	Captura de intervalo	
SISTEMA	Almacenamiento	
	Formato	
	USB a la PC	
	Temporizador	
	Intervalo de tiempo	

## Conexión HDMI

1

Conecte la unidad M11-8MV a una pantalla HDMI con el puerto de salida HDMI.

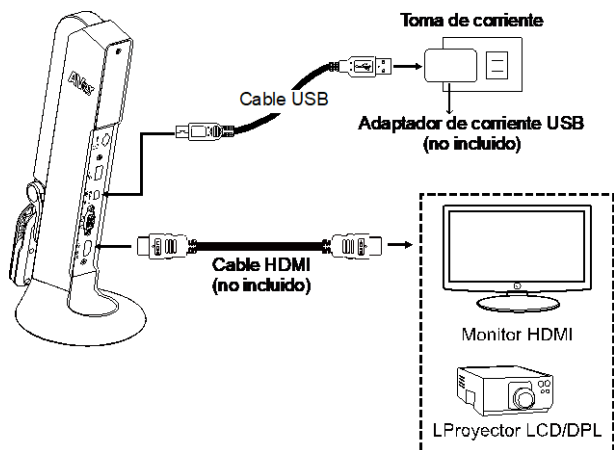

## Conexión VGA

1

Conecte la unidad M11-8MV a una pantalla VGA con el puerto de salida VGA.

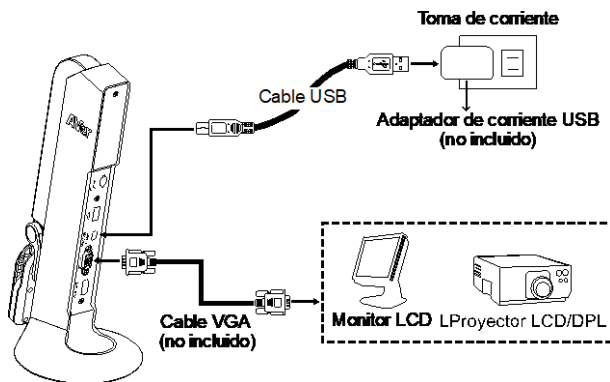

## Conexión USB

- 1 Conecte la unidad de memoria USB al puerto USB para guardar los archivos de captura y grabación.

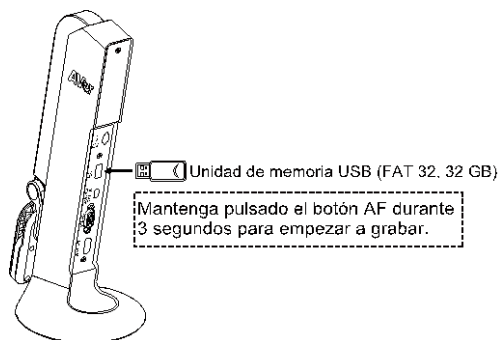

**[Nota]** Compatible con una unidad de memoria USB de hasta 32 GB (FAT32).

## Inserción de una tarjeta SD

- 1 Inserte la tarjeta en la ranura para tarjetas micro-SD.

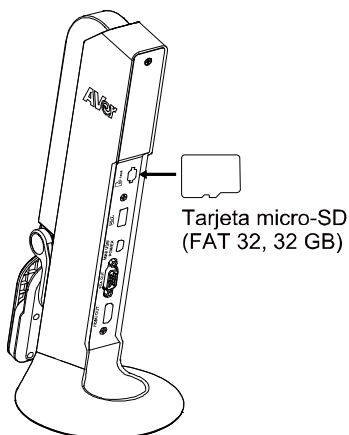

**[Nota]**

- Las tarjetas micro-SD permiten almacenar archivos de grabación y de imagen.
- La capacidad máxima permitida es de 32 GB (FAT 32).

# Uso de la cámara con AVerTouch

1

Conecte la cámara a un Pc/portátil e instale la aplicación AVerTouch.

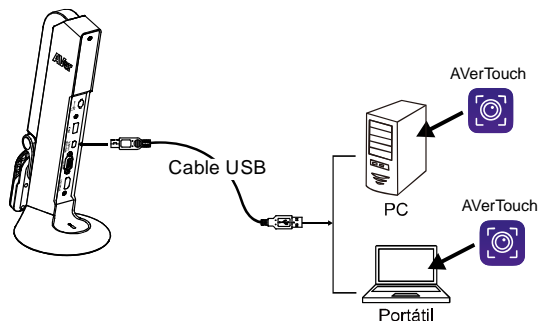

[Nota]

- Descargue la aplicación AVerTouch en: <https://www.avereurope.com/download-center/>
- Establezca la cámara en el modo USB. Vaya a **OSD Menu > Settings > USB to PC > USB Camera** (Menú OSD > Configuración > USB a PC > Cámara USB).

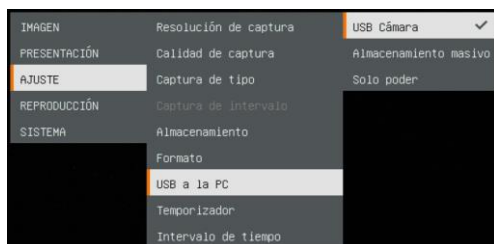

2

Abra la aplicación AVerTouch y haga clic en  para conectar la cámara.

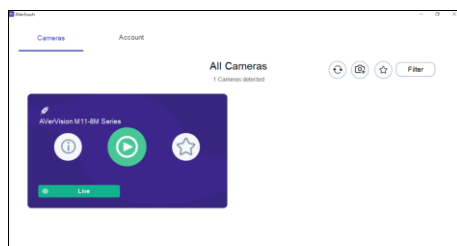

## Modo de presentación (en vivo)

[Nota] Antes de utilizar la característica de anotación o la función PIP/PBP del modo de presentación, establezca la cámara en el modo Solo fuente de alimentación. Vaya al menú **OSD > Ajuste > USB a la PC > Solo poder**.

### Anotación

En el modo (vista previa) de una sola imagen en vivo, el usuario puede utilizar la función de anotación para superponer una línea recta o a mano alzada en la imagen capturada con el ratón USB conectado al puerto USB de la M11-8MV.

1. Conecte el ratón al puerto USB de la M11-8MV.

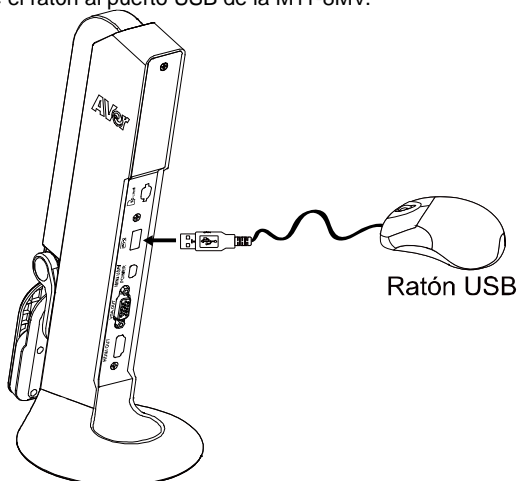

2. Vaya al menú **OSD > PRESENTACIÓN > Anotación**.

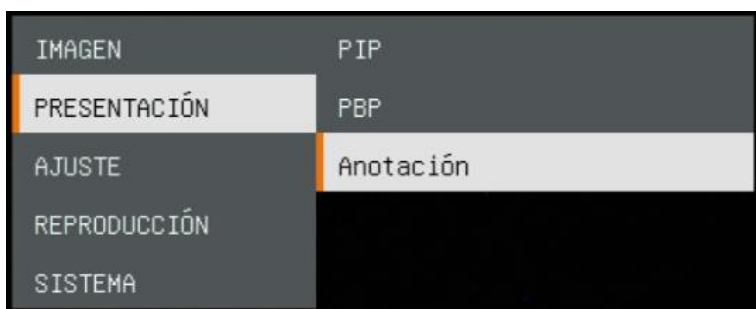



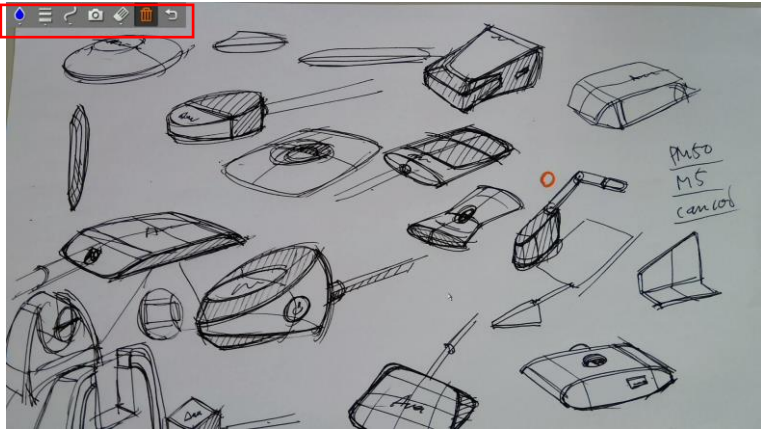







3. En la pantalla en vivo, haga clic con el botón derecho del ratón para visualizar la barra de anotaciones.



### Descripción de la barra de anotaciones



Botón	Función
 Paleta de colores	Seleccione el color de la línea. 
 Grosor de línea	Seleccione el grosor de la línea. 
 Línea	Seleccione una línea recta, una línea a mano alzada o una figura para dibujar. 
 Capturar	Capture la imagen con la anotación y guárdela como un archivo distinto.
 Borrador	Borre la anotación parcial o íntegramente.
 Eliminar	Elimine toda la anotación de la pantalla.
 Volver	Salga de la barra de anotaciones.

## Función PIP

Seleccione la ubicación de la pantalla de reproducción de miniaturas y muestre la pantalla de reproducción de miniaturas en la esquina de la pantalla para recuperar la imagen capturada de la tarjeta SD.





1. En el modo de cámara, mantenga pulsado el botón  durante tres segundos para abrir el menú OSD.
2. Utilice los botones  y  para ir a **Presentación > PIP**. Pulse  para confirmar la selección.
3. Seleccione la ubicación donde se visualizará la pantalla de reproducción de miniaturas: **Arriba a la izquierda, Superior derecha, Inferior izquierda o Inferior derecha**. Pulse  para confirmar la selección.





IMAGEN	PIP	Arriba a la izquierda
PRESENTACIÓN	PBP	Superior derecha
AJUSTE	Anotación	Inferior izquierda
REPRODUCCIÓN		Inferior derecha
SISTEMA		

4. Se mostrará la pantalla de visualización de PIP.

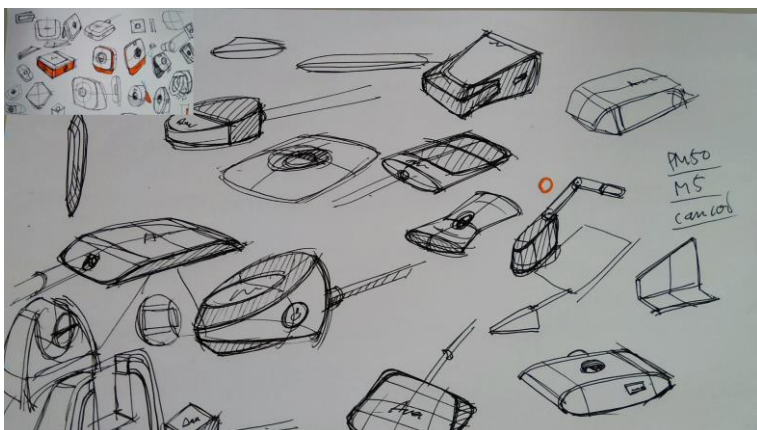

## Función PBP



Seleccione la ubicación de la imagen capturada y muestre la imagen captura en la pantalla para recuperar la imagen capturada de la tarjeta SD.

1. En el modo de cámara, mantenga pulsado el botón  durante tres segundos para abrir el menú OSD.
2. Utilice los botones  y  para ir a **Presentation > PBP**.  
(Presentación > PBP). Pulse  para confirmar la selección.
3. Seleccione la ubicación donde se visualizará la pantalla de reproducción de miniaturas: **Upper Left** (Parte superior izquierda), **Upper Right** (Parte superior derecha), **Lower Left** (Parte inferior izquierda) o **Lower Right** (Parte inferior derecha). Pulse  para confirmar la selección.

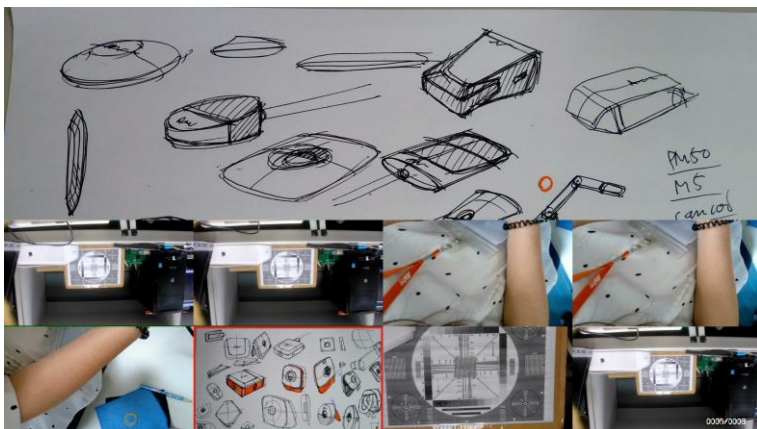

4. Utilice los botones  y  para seleccionar la imagen capturada en la lista



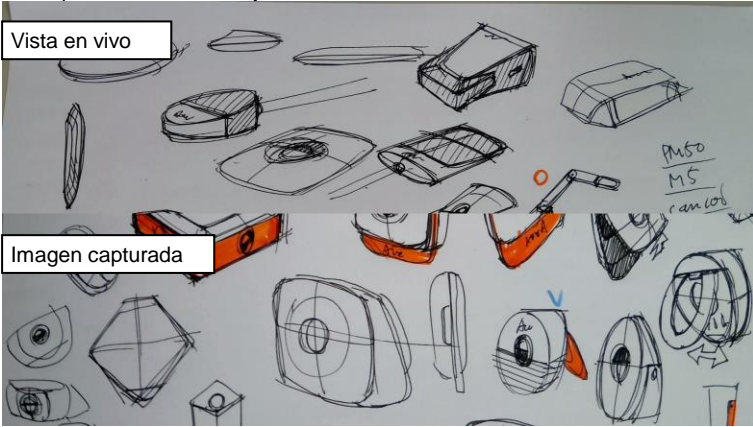

5. Se mostrará la pantalla de visualización de PBP (PBP se muestra en la ubicación inferior). Utilice los botones  y  para mover la imagen capturada arriba o abajo.











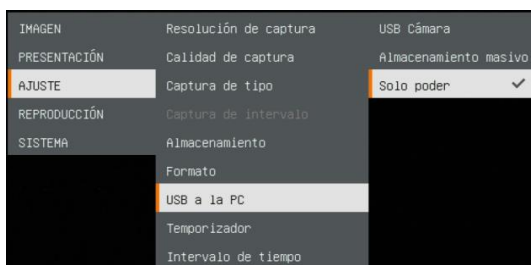



# Modo de reproducción

Visualice las imágenes capturadas y los archivos de grabación.

## Cambiar al modo de reproducción





1. En el modo de cámara, mantenga pulsado el botón  durante tres segundos para acceder al menú OSD.
2. Con los botones  y , vaya a **Ajuste > USB a la PC > Solo poder**.

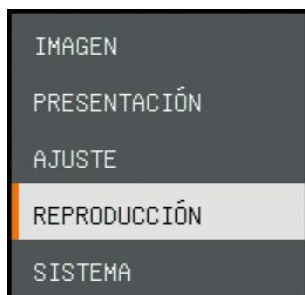













3. Con los botones ,  y , seleccione **PLAYBACK** (Reproducción).
4. Pulse  para confirmar la Selección y cambiar al modo de reproducción.
5. En el modo de reproducción, utilice los botones  +  y  +  para seleccionar las imágenes o videos para ver manualmente. Para reproducir un vídeo, pulse el botón . Para pausar la reproducción, vuelva a pulsar el botón . Pulse  para detener la reproducción.



## Botones del menú OSD

Botón	Función
	Vuelva a la última página deL nivel de menú
	Arriba (opción de selección)
	Abajo (opción de selección)
	Confirmar selección

## Botones del menú de reproducción

Botón	Función
 + 	■ Seleccionar imagen/vídeo
 + 	■  +  : Avanzar rápido mientras se reproduce un vídeo.
	■  +  : Retroceder rápido durante la reproducción del vídeo.
	Acercar imagen
	Alejar imagen
	<ul style="list-style-type: none"> <li>■ Reproducir vídeo</li> <li>■ Mantener pulsado para pausar el vídeo en reproducción</li> </ul>
	Detener reproducción

## Diapositivas

Para reproducir automáticamente todas las imágenes capturadas y todos los vídeos grabados (para los vídeos, solamente se mostrarán los archivos, no se reproducirán los contenidos).

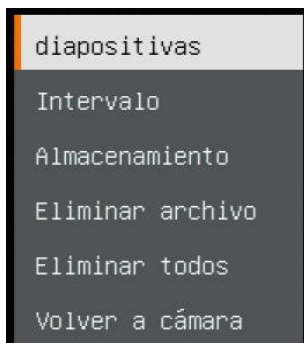

## Intervalo

Establezca el intervalo antes de que se muestre la próxima imagen. La duración puede establecerse en un máximo de 120 seg.

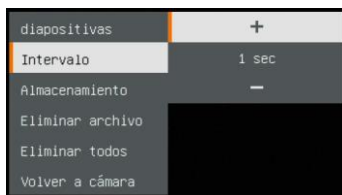

## Almacenamiento

Seleccione la fuente de las imágenes y los vídeos.



## Eliminar archivo

Elimine permanentemente la imagen o el vídeo seleccionados. Se mostrará un mensaje de advertencia. Seleccione **Sí** para continuar y **No** para cancelar.

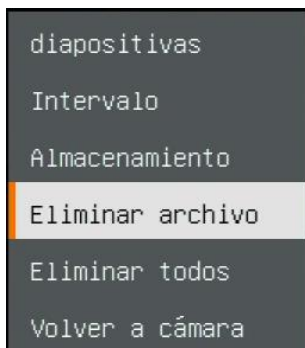
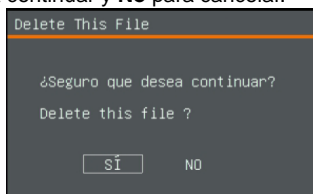

## Eliminar todos

Elimine permanentemente todos los datos en la fuente de memoria seleccionada. Se mostrará un mensaje de advertencia. Seleccione **Sí** para continuar y **No** para cancelar.

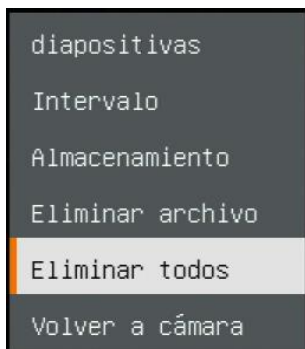
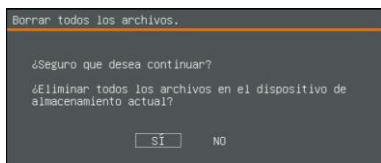



## Anotación

En el modo de reproducción de una sola imagen, el usuario puede utilizar la función de anotación para superponer una línea recta o a mano alzada en la imagen capturada con el ratón USB conectado al puerto USB de la M11-8MV.

**[Nota]** La función de anotación no se puede utilizar en archivos de vídeo.

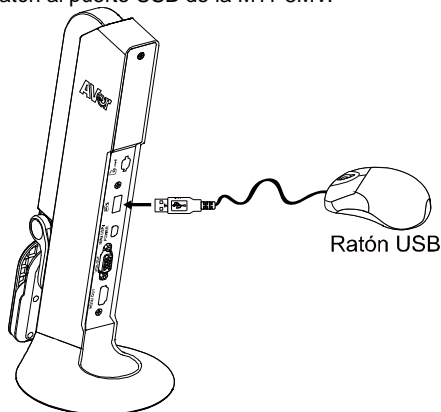
1. Conecte el ratón al puerto USB de la M11-8MV.



2. Pulse  para acceder al menú OSD.
3. Seleccione **"Playback"** (Reproducción).
4. Seleccione la imagen y se mostrará la barra de herramientas de reproducción. O haga clic con el botón derecho del ratón para acceder a la barra de herramientas de reproducción.

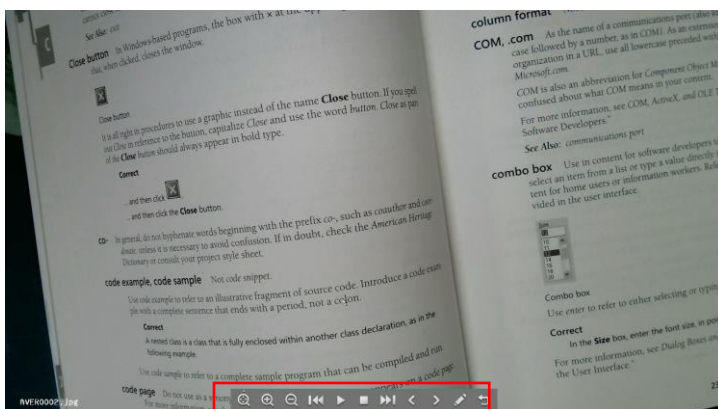









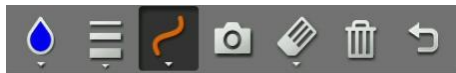
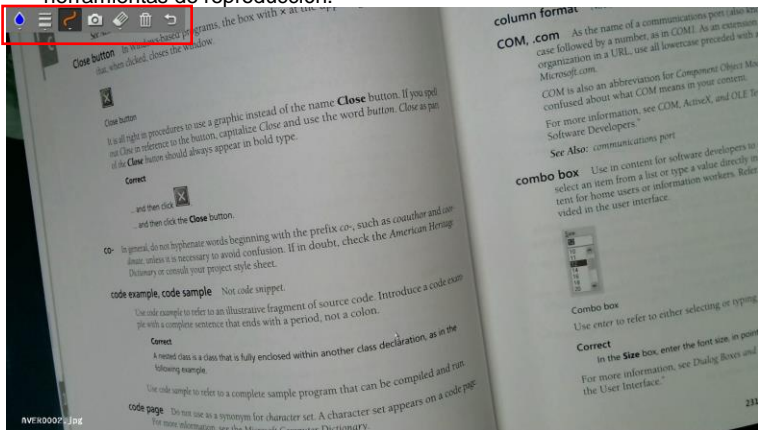

## Descripción de la barra de herramientas de reproducción



Botón	Función
	Mueva la imagen hacia la izquierda, derecha, arriba y abajo. Seleccione  para expandir los botones de dirección. 
	Acercar la imagen
	Alejar la imagen
	Retroceder rápido
	Iniciar reproducción de vídeo
	Detener reproducción de video
	Avanzar rápido
	Ir a la imagen o archivo siguiente o anterior
	Cambiar a la función de anotación 
	Volver a la lista de imágenes o archivos

5. Para cambiar al modo de anotación, seleccione  en la barra de herramientas de reproducción.



Button	Function
 Paleta de colores	Seleccione el color de la línea. 
 Grosor de línea	Seleccione el grosor de la línea. 
 Línea	Seleccione una línea recta, una línea a mano alzada o una figura para dibujar. 
 Capturar	Capture la imagen con la anotación y guárdela como un archivo distinto.
 Borrador	Borre la anotación parcial o íntegramente.
 Eliminar	Elimine toda la anotación de la pantalla.
 Atrás	Vuelva a la barra de herramientas de reproducción.

## Uso de la cámara

### Ángulo del cabezal de la cámara

Mueva el cabezal de la cámara como se indica en la figura.

**[PRECAUCIÓN]** Para no dañar el cabezal de la cámara, sujete el extremo del cabezal de la cámara para girarlo.

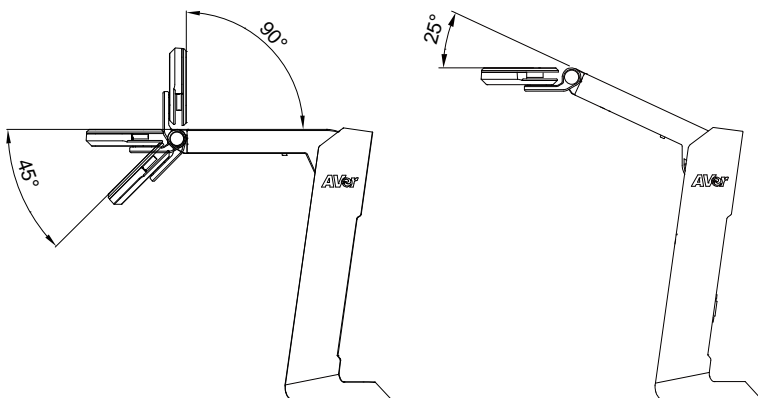
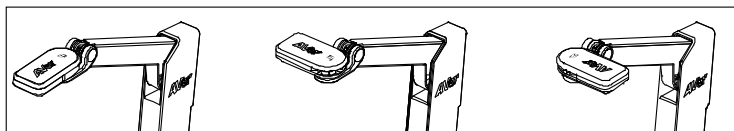

### Ángulo del cuerpo de la cámara

**[PRECAUCIÓN]** Para no dañar la cámara, **NO** estire el brazo más de 107°.

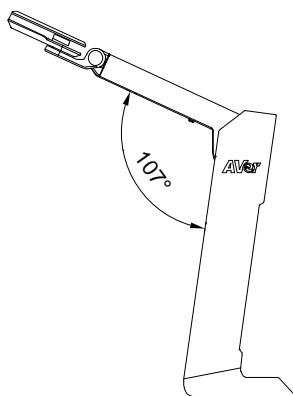

## Área de disparo

Cuando la cámara se encuentra a una altura de 342,4mm, el área de disparo se corresponde a un tamaño A3.

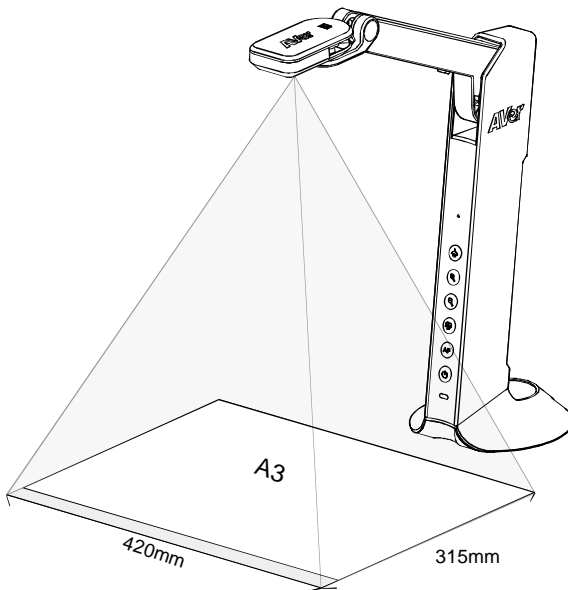
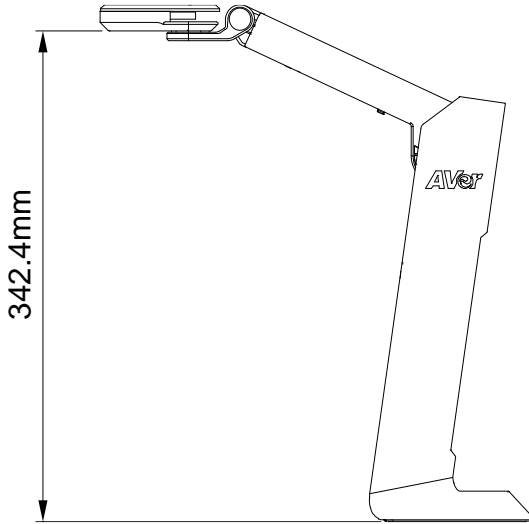

## Posición de los objetos

El icono en la parte superior del cabezal de la cámara permite al usuario colocar los objetos en la posición correcta (no invertidos).

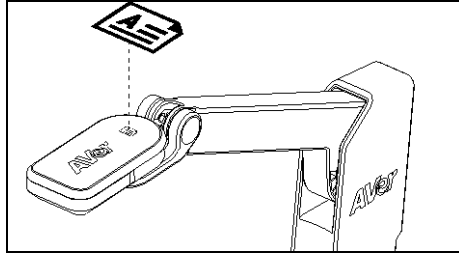

## Almacenamiento De La Cámara

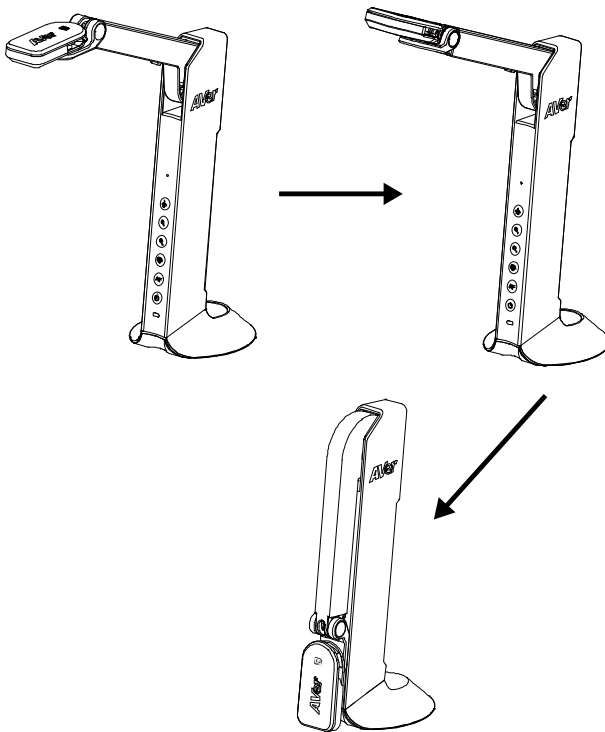

## Especificaciones

<b>Sensor</b>	Sensor CMOS de 1/3,06"
<b>Número de píxeles</b>	8 MP
<b>Velocidad de fotogramas</b>	Máx. 60 fps (pantalla)
<b>Modo de imagen</b>	Normal / Movimiento / Alta calidad
<b>Efecto</b>	Color / B&N / Negativo
<b>Enfoque</b>	Auto / Manual
<b>Área de disparo</b>	A3, 420 mm (an) * 315 mm (al)
<b>Zoom</b>	Zoom digital de 20x
<b>Fuente de alimentación</b>	Entrada mini-USB de 5 V y 1 A
<b>Consumo</b>	4,5 vatios (lámpara encendida) 4 vatios (lámpara apagada)
<b>Alimentación USB</b>	Sí, mediante puerto mini-USB
<b>Tipo de lámpara</b>	Luz LED
<b>USB</b>	USB 2.0 tipo A x1 (< 5 V/0,1 A, unidad de memoria USB FAT 32, 32 GB) USB tipo mini-B x 1 (alimentación)
<b>Salida USB</b>	3168 x 2376, 1920 x 1080, 1280 x 720, 1024 x 768, 800 x 600, 640 x 480
<b>Salida HDMI</b>	1920 x 1080, 1280 x 720, 720 x 480
<b>Salida VGA</b>	1920 x 1080, 1280 x 720, 720 x 480
<b>Captura de imagen</b>	120 imágenes (2 megapíxeles)
<b>Micrófono integrado</b>	Sí
<b>Ranura de tarjeta micro-SD</b>	FAT 32, 32 GB
<b>En uso</b>	360,4 mm (al) x 116,7 mm (an) x 303,4 mm (pr)
<b>Plegada</b>	296,1mm (al) x 116,7 mm (an) x 143,1 mm (pr)
<b>Peso neto</b>	1.83 lbs(0.83 Kg)
<b>Peso bruto</b>	2.87 lbs(1.301 Kg)
<b>Software compatible</b>	AVerTouch

## ADVERTENCIA

- No deje caer la cámara ni la someta a golpes.
- Utilice la tensión de alimentación adecuada para no dañar la cámara.
- No coloque la cámara en un sitio donde el cable pueda ser pisado; de lo contrario, el cable o el enchufe podrían deteriorarse o sufrir daños.
- Sostenga la parte inferior de la cámara con ambas manos para mover la cámara. No toque la lente ni el brazo flexible para mover la cámara.

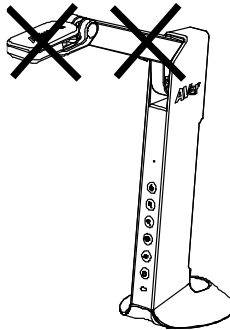

- Para reducir el riesgo de incendio o descarga eléctrica, no exponga el dispositivo a la lluvia o la humedad. En caso de realizarse modificaciones no autorizadas en el producto, se invalidará la garantía.
- No tire del brazo mecánico y la cámara en sentido contrario.

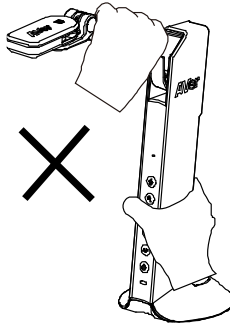

## COPYRIGHT

©2024 AVer Information Inc. Todos los derechos reservados.

## **AVISO**

LAS ESPECIFICACIONES ESTÁN SUJETAS A CAMBIO SIN PREVIO AVISO. LA INFORMACIÓN CONTENIDA EN EL PRESENTE DOCUMENTO SE OFRECE EXCLUSIVAMENTE A TÍTULO DE REFERENCIA.

## **MARCAS COMERCIALES**

«AVer» es una marca comercial propiedad de AVer Information Inc. Otras marcas comerciales utilizadas en este documento con fines descriptivos pertenecen exclusivamente a sus empresas correspondientes.

## **PRECAUCIÓN**

Existe riesgo de explosión si la batería se sustituye por un tipo de batería incorrecto. Deseche las baterías usadas de acuerdo con las instrucciones.

## **Ayuda Adicional**

Para preguntas frecuentes, soporte técnico y descargas de software y manuales de instrucciones, visite:

### **Sede europea:**

<https://www.avereurope.com/download-center/>

### **Soporte técnico:**

<https://es.avereurope.com/technical-support>

## **Información de contacto**

AVer Information Europe B.V.

Westblaak 134, 3012 KM, Rotterdam, The Netherlands

Tel.: +31 (0) 10 7600 550

## Contenuto della confezione

I seguenti articoli vengono forniti in dotazione con questo prodotto. Qualora vi siano articoli mancanti, contattare il rivenditore presso il quale è stato acquistato il prodotto.

Unità M11-8MV

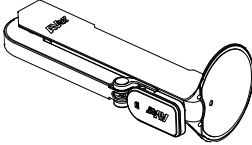

Cavo USB

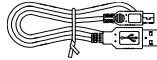

Scheda QR Code



Scheda di garanzia \*



\* Solo per Giappone, Taiwan, ed Europa

## Accessori opzionali

Borsa di trasporto



Foglio anti-riflesso





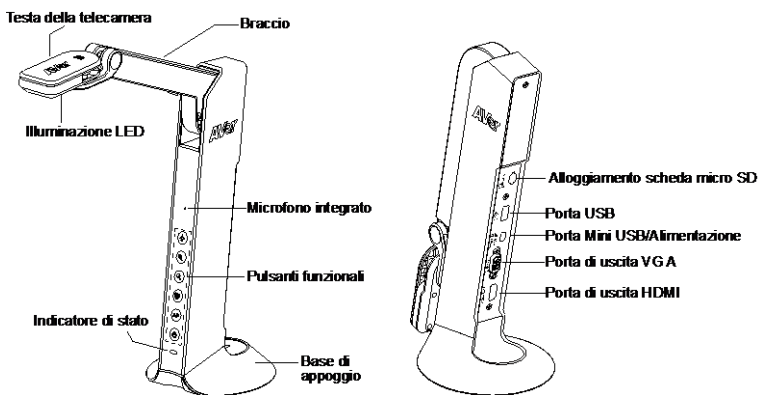



# Panoramica







## Pulsanti funzione

### Pannello di controllo





Pulsante	Funzione
	<ul style="list-style-type: none"> <li>■ Lampada ON/OFF</li> <li>■ Premere e tenere premuto per 3 secondi per richiamare il menu OSD.</li> </ul>
	Ingrandimento
	Rimpicciolimento
	<ul style="list-style-type: none"> <li>■ Ruota 0/180°</li> <li>■ Premere e tenere premuto per 3 secondi per bloccare lo schermo. Sbloccare, premere e tenere premuto per 3 secondi nuovamente.</li> </ul>
	<ul style="list-style-type: none"> <li>■ Messa a fuoco automatica</li> <li>■ Premere e tenere premuto per 3 secondi per avviare la registrazione.</li> </ul> <p>Per interrompere la registrazione, premere e tenere premuto  per 3 secondi nuovamente</p>
	Accensione e spegnimento

## Modalità OSD

Pulsante	Funzione
	<ul style="list-style-type: none"> <li>■ Torna all'ultima pagina livello menu</li> <li>■ Esci dal menu OSD</li> </ul>
	Su (selezione opzione)
	Giù (selezione opzione)
	Inserimento della selezione

## Tasto composto

Premere i tasti per azionare la funzione tasto composto.

Pulsante	Funzione
 + 	Esegui il ripristino alle impostazioni predefinite di fabbrica.
 + 	Acquisisci immagine

**[Nota]** Per le operazioni di **Registrazione** e **Acquisizione**, si prega di passare alla modalità **“Solo alimentazione”**.



## Spia LED

<b>Alimentazione</b> 	<b>Verde fisso:</b> Acceso <b>Rosso fisso:</b> Stand-by <b>Rosso lampeggiante:</b> La telecamera è in fase di avvio
---	---

# Collegamento dispositivo

## Collegamento di alimentazione alla presa a parete

1

Collegare l'alimentazione e accendere il dispositivo M11-8MV.

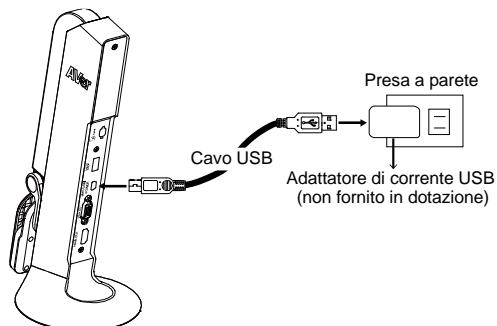

### [Nota]

- Utilizzare il cavo USB incluso nella confezione che collega la mini porta USB/alimentazione del dispositivo M11-8MV con adattatore di alimentazione USB (non fornito in dotazione) alla presa di corrente a muro.
- Gli utenti devono acquistare un alimentatore da 5V/1A USB (non fornito in dotazione) per collegare il cavo USB alla presa a parete.
- Quando la telecamera è in fase di avvio, la spia di alimentazione lampeggia di colore rosso.

## Collegamento di alimentazione a PC/Laptop

1 Collegare alla porta USB del PC/laptop per l'alimentazione.

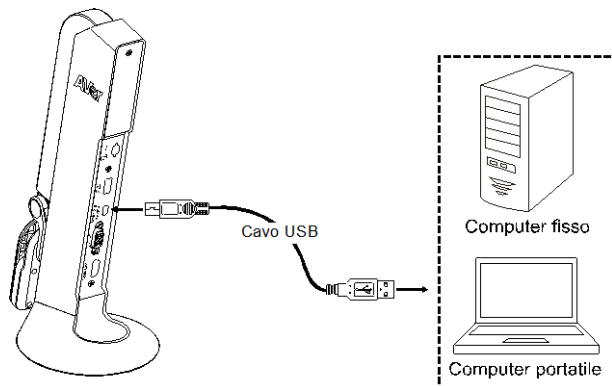

### [Nota]

- Utilizzare il cavo USB fornito in dotazione per eseguire il collegamento alla mini porta USB/alimentazione di M11-8MV con laptop/PC.
- Quando la telecamera è in fase di avvio, la spia di alimentazione lampeggia di colore rosso.
- Il requisito di alimentazione USB del dispositivo M11-8MV è USB 5V/1A.
- Per le funzioni di archiviazione, formattazione, cattura, registrazione e riproduzione si prega di passare alla modalità "Solo alimentazione"

IMAGE	Risoluzione di cattura	USB Fotocamera
PRESENTAZIONE	Qualità di cattura	Memoria di massa
SETTING	Tipo di cattura	Solo alimentazione ✓
PLAYBACK	Intervallo di cattura	
SYSTEM	Archiviazione	
	Formatta	
	Da USB a PC	
	Timer	
	Intervallo timer	

## Collegamento HDMI

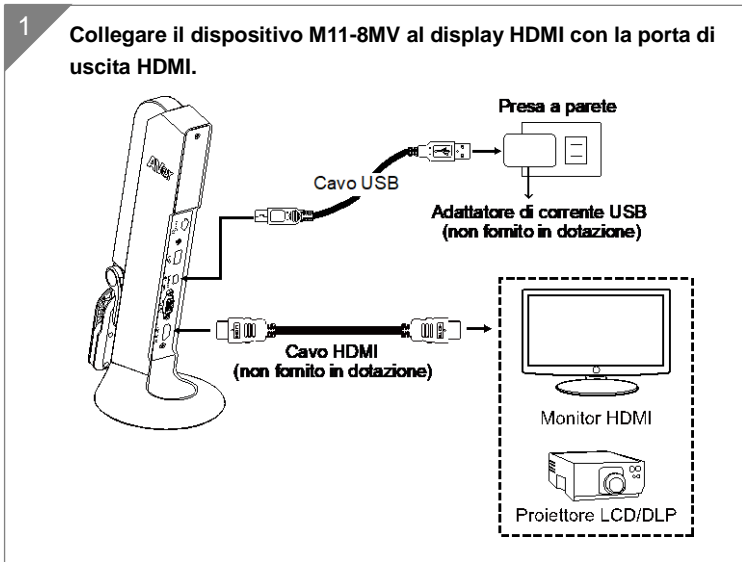

## Collegamento VGA

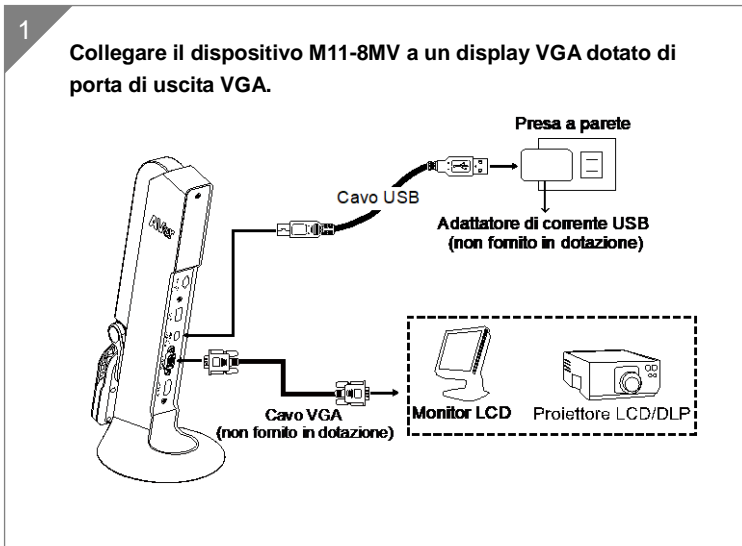

## Collegamento USB

- 1 Collegare il drive flash USB alla porta USB per salvare l'acquisizione e il file della registrazione.

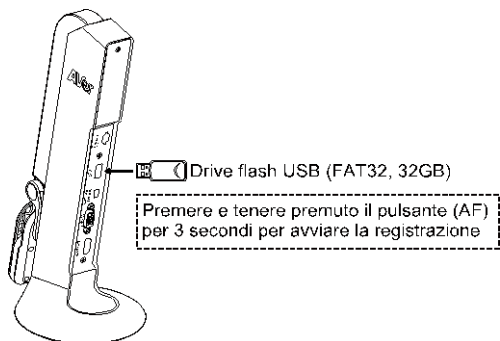

**[Nota]** Le dimensioni massime supportate del drive flash USB sono 32G (FAT32).

## Inserire una scheda Micro SD

- 1 Inserire la scheda nell'alloggiamento per scheda micro SD.

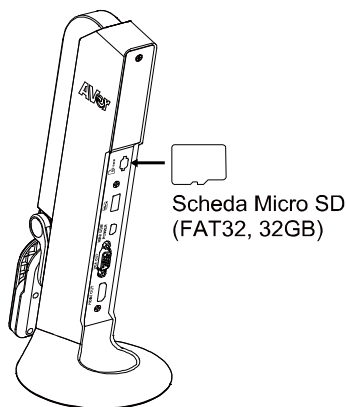

**[Nota]**

- La scheda Micro SD consente di archiviare le immagini delle acquisizioni e i file della registrazione.
- La capacità massima supportata della scheda SD è 32G (FAT32).

# Usare la telecamera con AVerTouch

1

Collegare la telecamera a un PC/laptop e installare l'applicazione AVerTouch.

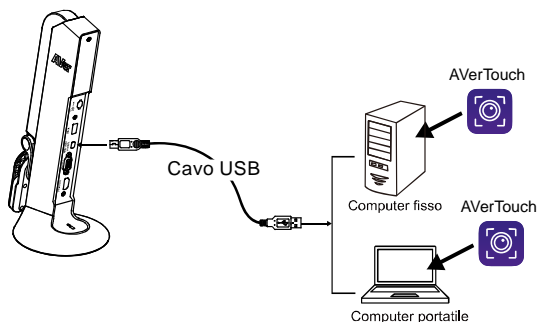

[Nota]

- Scaricare l'applicazione AVerTouch sul sito:  
<https://www.aver.com/download-center/>
- Impostare la telecamera in modalità USB. Andare su **menu OSD > Impostazione > Da USB a PC > USB Fotocamera**.

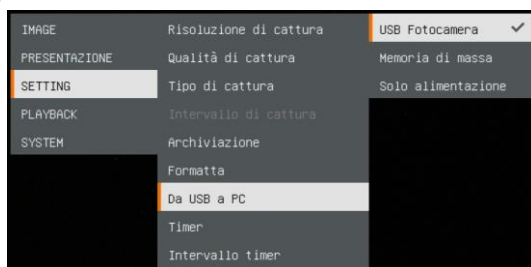

2

Aprire l'applicazione AVerTouch, fare clic su  per collegare la telecamera.

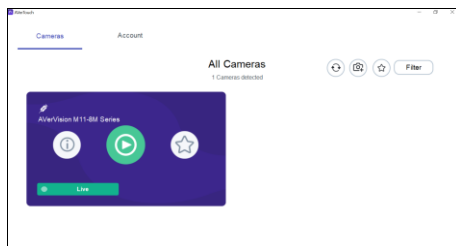

## Modalità Presentazione (Live)

**[Nota]** Prima di usare la funzione di annotazione o la funzione PIP/PBP della modalità di presentazione, impostare la fotocamera come prima cosa sulla modalità Solo Alimentazione. Andare sul menu **OSD > IMPOSTAZIONE > Da USB a PC > Solo Alimentazione**.

### Annotazione

Nella modalità Immagine singola (anteprima), l'utente può usare la funzione annotazione per apporre una riga dritta o una forma libera sull'immagine catturata con il mouse USB collegato alla porta USB del dispositivo M11-8MV.

1. Collegare il mouse alla porta USB del dispositivo M11-8MV.

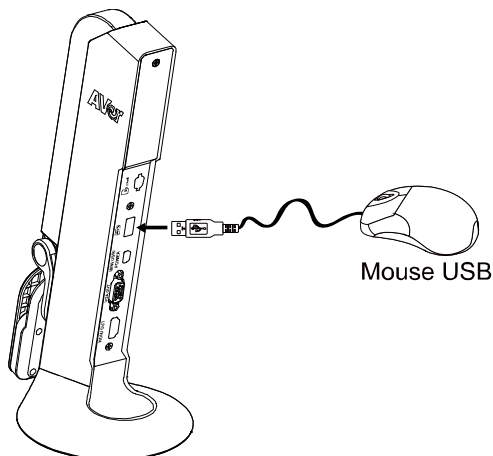

2. Andare al menu **OSD > PRESENTAZIONE > Annotazione**.

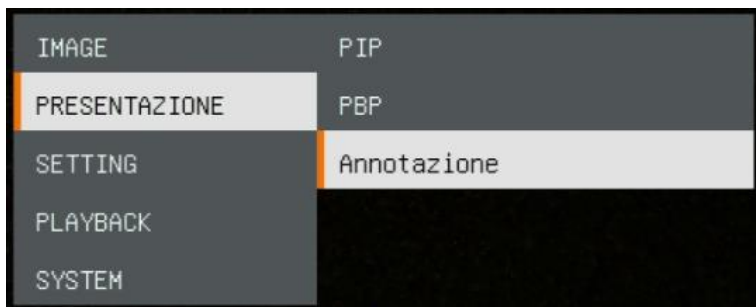



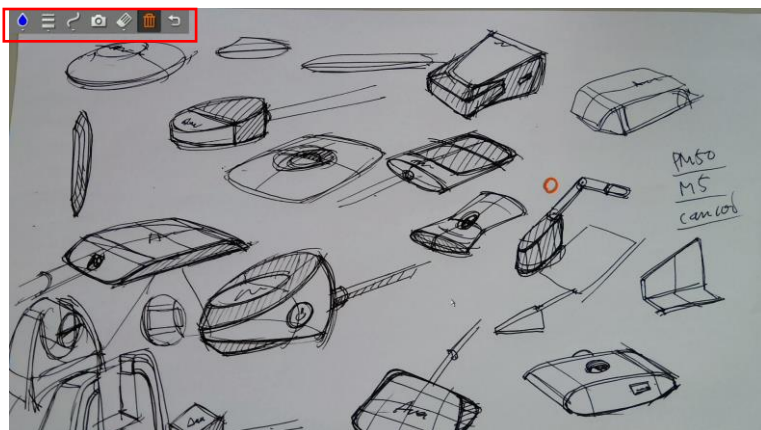







3. Nella schermata live, fare clic con il tasto destro del mouse per richiamare la barra delle annotazioni.



## Descrizione della barra delle annotazioni



Pulsante	Funzione
 Palette colori	Selezionare il colore della riga. 
 Spessore linea	Selezionare lo spessore della riga. 
 Linea	Selezionare una riga dritta, una forma a mano libera o una forma per disegnare. 
 Cattura	Cattare l'immagine con l'annotazione e salvarla come nuovo file.
 Gomma	Selezionare per cancellare qualsiasi parte dell'annotazione che entri in contatto, oppure eliminare tutta l'annotazione.
 Elimina	Cancellare tutte le annotazioni sullo schermo.
 Indietro	Esci dalla barra di annotazione.

## Funzione PIP

Selezionare la posizione della schermata di riproduzione delle miniature e mostrare la schermata di riproduzione delle miniature nell'angolo dello schermo per richiamare l'immagine catturata dalla scheda SD.





1. Nella modalità fotocamera, premere e tenere premuto il pulsante  per 3 secondi per richiamare il menu OSD.
2. Usare il pulsante  e  per passare a **Presentazione > PIP**.  
Premere  per confermare la selezione.
3. Selezionare la posizione del display della schermata di riproduzione delle miniature– **Sinistra superiore, Destra superiore, Sinistra inferiore, o Destra inferiore**. Premere  per confermare la selezione.





IMAGE	PIP	Superiore sinistro
PRESENTAZIONE	PBP	In alto a destra
SETTING	Annotazione	In basso a sinistra
PLAYBACK		In basso a destra
SYSTEM		

4. La schermata PIP si presenta come segue.

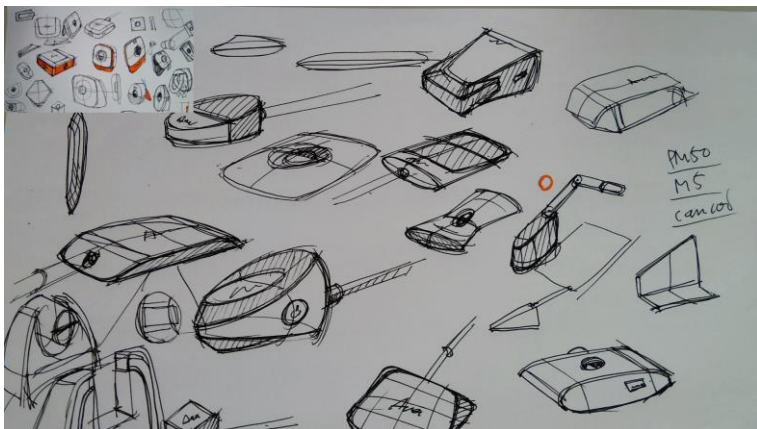

## Funzione PBP

Selezionare la posizione dell'immagine catturata e mostrare l'immagine catturata sullo schermo per richiamare l'immagine catturata dalla scheda SD.

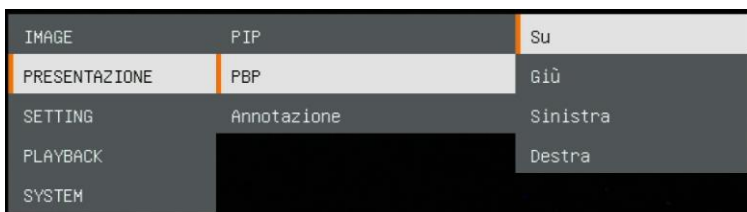

1. In modalità fotocamera, premere e tenere premuto il pulsante  per 3 secondi per richiamare il menu OSD.
2. Usare il pulsante  e  per spostarsi su **Presentazione > PBP**.  
Premere  per confermare la selezione.
3. Selezionare la posizione del display della riproduzione miniature– **Sinistra superiore, Destra superiore, Sinistra inferiore, o Destra inferiore**.

Premere  per confermare la selezione.

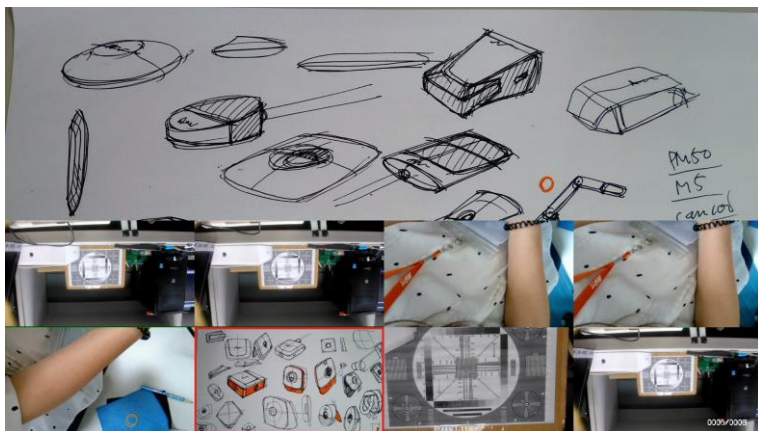

4. Usare i pulsanti  e  per selezionare l'immagine catturata dall'elenco



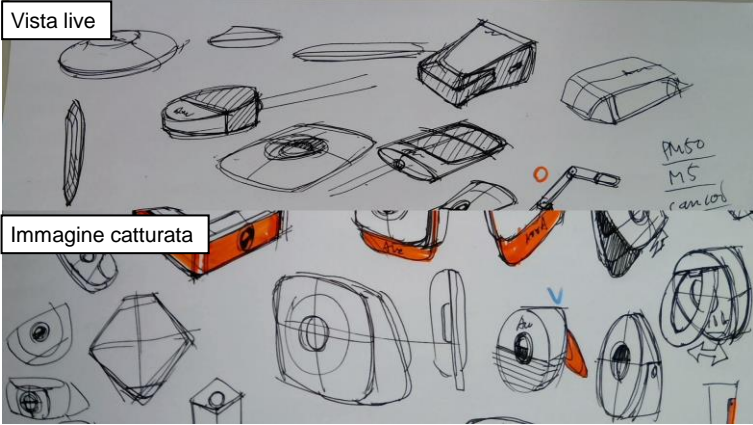

5. La schermata PBP si presenta come segue (PBP è in posizione giù). Usare il pulsante  e  per spostare l'immagine catturata (alto) e per visualizzare (basso).











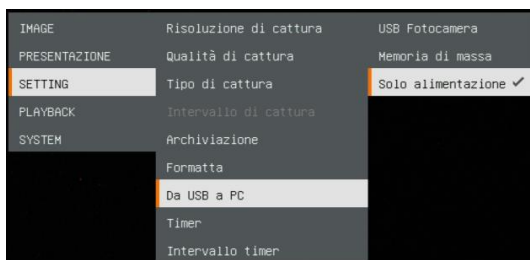



# Modalità riproduzione

Guardare le immagini acquisite e i file registrati.

## Passare alla Modalità riproduzione





1. Nella modalità telecamera, premere e tenere premuto il pulsante  per 3 secondi per richiamare il menu OSD.
2. Usare i pulsanti  e  per passare a **SETTING(impostazioni)** > **Da USB a PC** > **Solo alimentazione**.

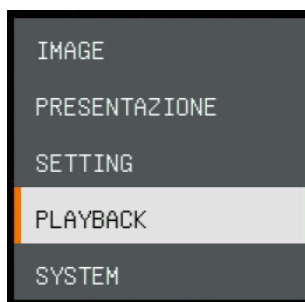













3. Usare ,  e il pulsante  per passare alla selezione **Playback**.
4. Quindi, premere per  confermare la selezione e passare alla modalità di riproduzione.
5. Nella modalità di riproduzione, usare i pulsanti  +  e  +  per selezionare l'immagine o il video da visualizzare preimpostati. Per riprodurre un video, premere il pulsante  per avviare la riproduzione. Per mettere in pausa la riproduzione, premere nuovamente il pulsante . Premere  per riprodurre la riproduzione.



## Pulsanti menu OSD

Pulsante	Funzione
	Torna all'ultima pagina livello menu
	Su (selezione opzione)
	Giù (selezione opzione)
	Inserimento della selezione

## Pulsanti menu riproduzione

Pulsante	Funzione
 +   + 	<ul style="list-style-type: none"><li>■ Selezione immagine / video</li><li>■  + : Avanzamento rapido in fase di riproduzione del video</li><li>■  + : Riavvolgimento rapido in fase di riproduzione del video</li></ul>
	Ingrandimento immagine
	Rimpicciolimento immagine
	<ul style="list-style-type: none"><li>■ Riproduci video</li><li>■ Premere e tenere premuto per mettere in pausa il video mentre è in fase di riproduzione.</li></ul>
	Interrompere la riproduzione del video

## Presentazione

Per riprodurre automaticamente tutte le immagini acquisite e i video registrati; per quanto riguarda i video verranno visualizzati solo i file ma non verranno riprodotti i contenuti video.

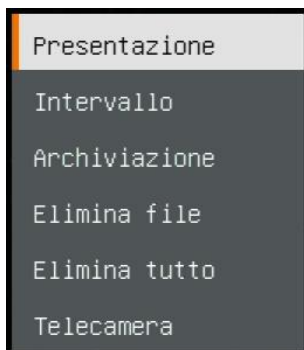

## Intervallo

Imposta l'intervallo prima di visualizzare l'immagine successiva. La lunghezza può essere impostata fino a un massimo di 120 secondi.

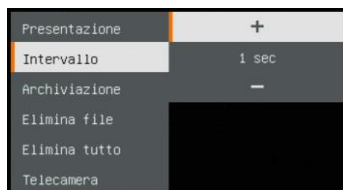

## Archiviazione

Selezionare la sorgente delle immagini e dei video.



## Elimina file

Elimina in modo permanente l'immagine o il video selezionati. Apparirà un messaggio di avvertimento. Selezionare **Si** per continuare e **No** per annullare l'eliminazione.

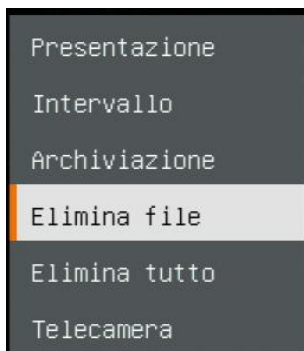
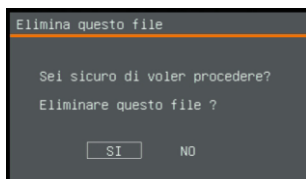

## Elimina tutto

Elimina in modo definitivo tutti i dati contenuti nella sorgente di memoria selezionata. Apparirà un messaggio di avvertimento. Selezionare **Si** per continuare e **No** per annullare l'eliminazione.

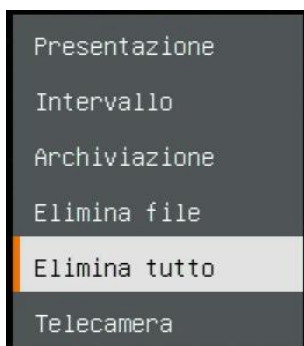
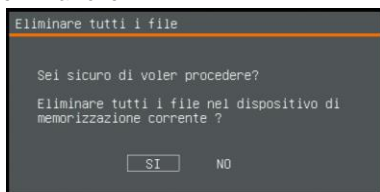



## Annotazione

Nella modalità riproduzione singola immagine l'utente può usare la funzione di annotazione per apporre una riga dritta o una riga forma libera sull'immagine acquisita con il mouse USB connesso alla porta USB del dispositivo M11-8MV.

**[Nota]** La funzione di annotazione non supporta l'annotazione su file video.

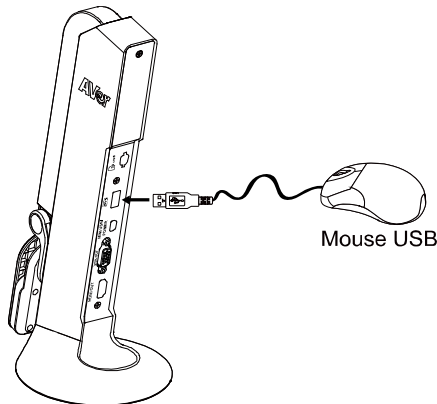
1. Collegare il mouse alla porta USB del dispositivo M11-8MV.



2. Premere  per richiamare il menu OSD.
3. Selezionare **"Riproduzione"**.
4. Selezionare l'immagine e la barra dello strumento di riproduzione viene visualizzata. In alternativa fare clic con il tasto destro del mouse per richiamare la barra degli strumenti di riproduzione.

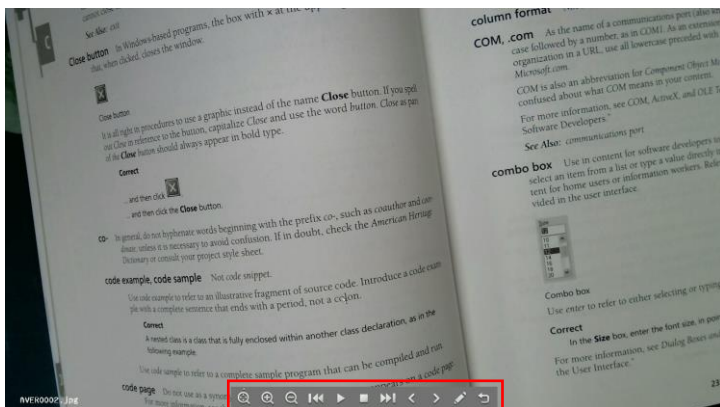









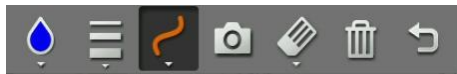
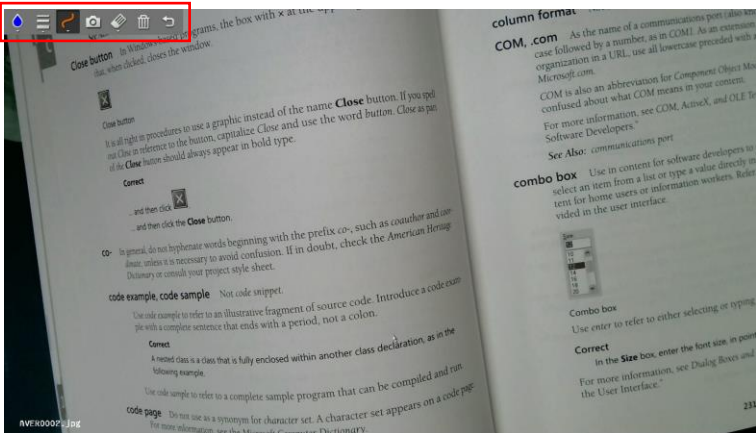

**Playback tool bar description**



Pulsante	Funzione
	<p>Spostare l'immagine a sinistra, destra, su e giù.</p> <p>Selezionare  per espandere i pulsanti direzionali.</p>
	Ingrandisci immagine
	Rimpicciolisci immagine
	Riavvolgimento rapido
	Inizia la riproduzione dei video
	Concludi la riproduzione dei video
	Avanzamento rapido
	Vai al successivo o torna all'ultima immagine o file
	<p>Passa alla funzione annotazioni.</p>
	Torna all'immagine o all'elenco dei file

5. Per passare alla modalità annotazione, selezionare  sulla barra degli strumenti di riproduzione.



Button	Function
 Palette colori	Selezionare il colore della riga. 
 Spessore linea	Selezionare lo spessore della riga. 
 Linea	Selezionare una riga dritta, una forma a mano libera o una forma per disegnare. 
 Cattura	Cattare l'immagine con l'annotazione e salvarla come nuovo file.
 Gomma	Selezionare per cancellare qualsiasi parte dell'annotazione che entri in contatto, oppure eliminare tutta l'annotazione.
 Elimina	Cancellare tutte le annotazioni sullo schermo.
 Indietro	Torna alla barra degli strumenti della riproduzione

# Utilizzo della telecamera

## Angolazione della testa della telecamera

Spostare la testa della telecamera come indicato nella figura.

**[ATTENZIONE]** Per evitare di danneggiare la testa della telecamera, tenere il bordo della testa della telecamera per farla ruotare.

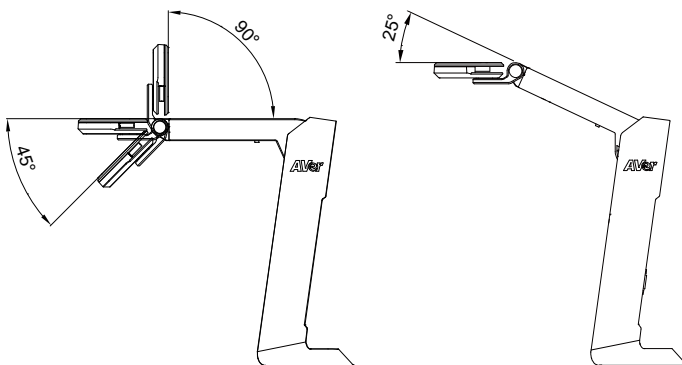
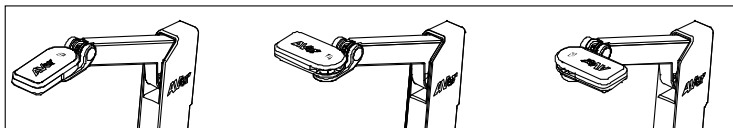

## Angolazione del corpo della telecamera

**[ATTENZIONE]** Per evitare di danneggiare l'unità telecamera, **NON** tirare l'angolazione del braccio a più di 107°.

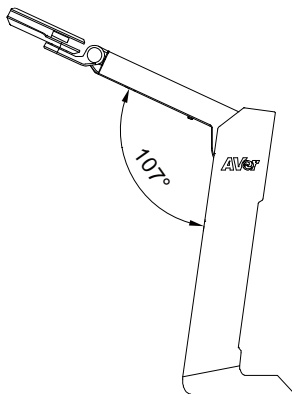

## Area di ripresa

Quando la posizione della telecamera è a un'altezza di 342,4 mm, l'area di ripresa sarà della dimensione di un foglio A3.

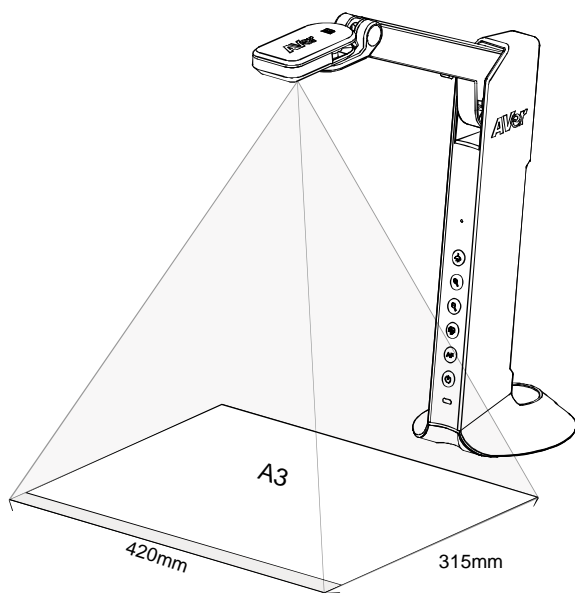
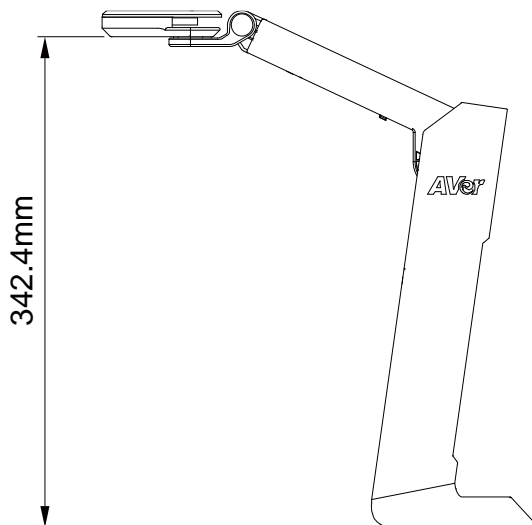

## Posizione dell'oggetto

L'icona sulla parte superiore della telecamera può aiutare l'utente a collocare gli oggetti in una direzione positiva.

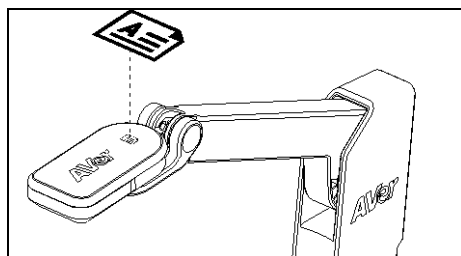

## Archiviazione nella telecamera

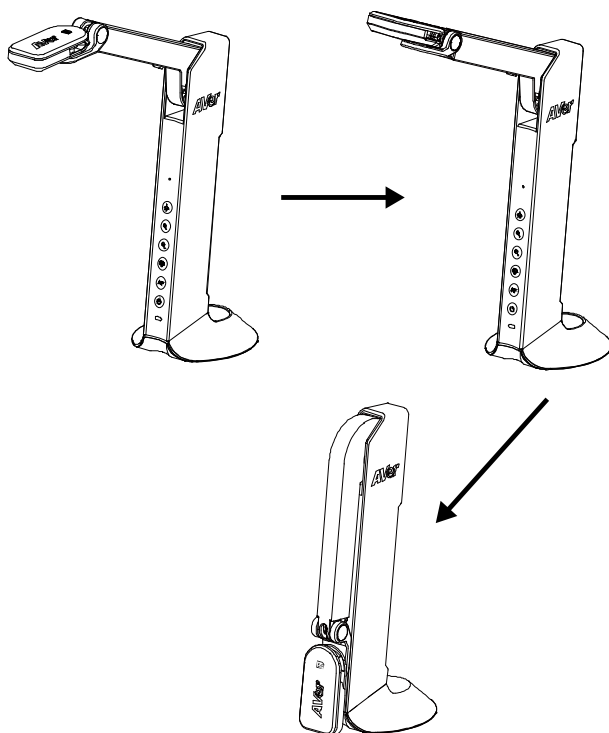

## Specifiche tecniche

<b>Sensore</b>	Sensore CMOS 1/3.06"
<b>Conteggio pixel</b>	8MP
<b>Frame Rate</b>	Max.60fps (display)
<b>Modalità immagine</b>	Normale/Movimento /Alta qualità
<b>Effetto</b>	Colore / Bianco&Nero / Negativo
<b>Messa a fuoco</b>	Auto/Manuale
<b>Area di ripresa</b>	A3,420mm(H) * 315mm(V)
<b>Ingrandimento</b>	Zoom digitale 20x
<b>Fonte di alimentazione</b>	Mini-USB in, 5V/1A
<b>Consumo</b>	4.5 Watt (lampada accesa) 4 Watt (lampada spenta)
<b>Alimentazione bus USB</b>	Sì, tramite porta mini-USB
<b>Tipo di lampada</b>	Spia LED
<b>USB</b>	USB2.0 Tipo-A x1 (< 5V/0.1A, drive flash USB FAT32, 32GB) USB Tipo mini-B x 1(Alimentazione)
<b>Uscita USB</b>	3168 x 2376, 1920 x 1080, 1280 x 720, 1024 x 768, 800 x 600, 640 x 480
<b>Uscita HDMI</b>	1920 x 1080, 1280 x 720, 720 x 480
<b>Uscita VGA</b>	1920 x 1080, 1280 x 720, 720 x 480
<b>Cattura immagine</b>	120 immagini (2 megapixel)
<b>MIC integrato</b>	Sì
<b>Alloggiamento scheda Micro SD</b>	FAT 32,32GB
<b>Funzionamento</b>	360.4mm(H)*116.7mm(L)*303.4mm(P)
<b>Chiuso</b>	296.1mm(H)*116.7mm(L)*143.1mm(P)
<b>Peso netto</b>	1.83 lbs(0.83 Kg)
<b>Peso lordo</b>	2.87 lbs(1.301 Kg)
<b>Assistenza software</b>	AVerTouch

## AVVERTENZA

- Non lasciar cadere la fotocamera e non sottoporla a urti fisici.
- Utilizzare la corretta tensione di alimentazione per evitare di danneggiare la telecamera.
- Non posizionare la fotocamera in un punto in cui il cavo possa essere calpestato, in quanto ciò potrebbe causare lo sfilacciamento o il danneggiamento del cavo o della spina.
- Non tirare il braccio meccanico e la parte della telecamera nella direzione opposta.

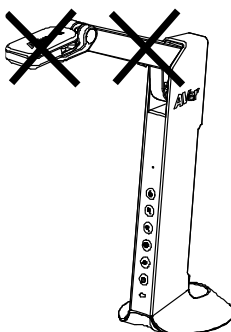

- Per ridurre il rischio di incendio o di scosse elettriche, non esporre questo dispositivo alla pioggia o all'umidità. La garanzia decade in caso di modifiche non autorizzate al prodotto.
- Tenere la parte inferiore della fotocamera con entrambe le mani per spostare la fotocamera. Non afferrare l'obiettivo o il braccio flessibile per spostare la fotocamera.

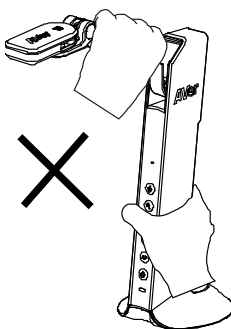

## COPYRIGHT

©2024 AVer Information Inc. Tutti i diritti riservati.

## **INFORMATIVA**

LE SPECIFICHE SONO SOGGETTE A VARIAZIONI SENZA REAVVISO.  
LE INFORMAZIONI QUI CONTENUTE SONO PRESENTATE  
UNICAMENTE A SCOPO DI RIFERIMENTO.

## **MARCHI COMMERCIALI**

“AVer” è un marchio registrato da AVer Information Inc. Altri marchi commerciali qui usati unicamente a scopo descrittivo appartengono alle rispettive aziende.

## **ATTENZIONE**

Rischio di esplosione se la batteria è sostituita con una di tipo errato.  
Smaltire le batterie usate a seconda delle istruzioni.

## **Altro Aiuto**

Per Domande tecniche, assistenza tecnica, download di software e manuale di istruzioni, invitiamo a visitare:

### **European Headquarters:**

<https://www.avereurope.com/download-center/>

### **Assistenza tecnica:**

<https://www.avereurope.com/technical-support>

## **Informazioni di contatto**

AVer Information Europe B.V.

Westblaak 134, 3012 KM, Rotterdam, The Netherlands

Tel: +31 (0) 10 7600 550