

L16u

User Manual



FCC NOTICE (Class A)



This device complies with Part 15 of the FCC Rules. Operation is subject to the following two conditions: (1) this device may not cause harmful interference, and (2) this device must accept any interference received, including interference that may cause undesired operation.

Federal Communications Commission Statement

NOTE- This equipment has been tested and found to comply with the limits for a Class A digital device, pursuant to Part 15 of the FCC Rules. These limits are designed to provide reasonable protection against harmful interference in a residential installation. This equipment generates uses and can radiate radio frequency energy and, if not installed and used in accordance with the instructions, may cause harmful interference to radio communications. However, there is no guarantee that interference will not occur in a particular installation. If this equipment does cause harmful interference to radio or television reception, which can be determined by tuning the equipment off and on, the user is encouraged to try to correct the interference by one or more of the following measures:

- Reorient or relocate the receiving antenna.
- Increase the separation between the equipment and receiver.
- Connect the equipment into an outlet on a circuit different from that to which the receiver is connected.
- Consult the dealer or an experienced radio/television technician for help.

Class A ITE

Class A ITE is a category of all other ITE which satisfies the class A ITE limits but not the class B ITE limits. Such equipment should not be restricted in its sale but the following warning shall be included in the instructions for use:

Warning -This is a class A product. In a domestic environment this product may cause radio interference in which case the user may be required to take adequate measures.

European Community Compliance Statement (Class A)



This product is herewith confirmed to comply with the requirements set out in the Council Directives on the Approximation of the laws of the Member States relating to Electromagnetic Compatibility Directive 2014/30/EU.

Warning - This is a Class A product. In a domestic environment this product may cause radio interference in which case the user may be required to take adequate measures to correct this interference.

DISCLAIMER

No warranty or representation, either expressed or implied, is made with respect to the contents of this documentation, its quality, performance, merchantability, or fitness for a particular purpose. Information presented in this documentation has been carefully checked for reliability; however, no responsibility is assumed for inaccuracies. The information contained in this documentation is subject to change without notice.

In no event will AVer Information Inc. be liable for direct, indirect, special, incidental, or consequential damages arising out of the use or inability to use this product or documentation, even if advised of the possibility of such damages.

TRADEMARKS

“AVer” is a trademark owned by AVer Information Inc. Other trademarks used herein for description purpose only belong to each of their companies.

COPYRIGHT

©2015 AVer Information Inc. All rights reserved.

All rights of this object belong to AVer Information Inc. Reproduced or transmitted in any form or by any means without the prior written permission of AVer Information Inc. is prohibited. All information or specifications are subject to change without prior notice.

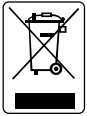

The mark of Crossed-out wheeled bin indicates that this product must not be disposed of with your other household waste. Instead, you need to dispose of the waste equipment by handing it over to a designated collection point for the recycling of waste electrical and electronic equipment. For more information about where to drop off your waste equipment for recycling, please contact your household waste disposal service or the shop where you purchased the product.

CAUTION

- To reduce risk of electric shock use only indoors.
- Only adults should move the L16u cabinet.
- Do not allow anyone to sit, stand, or climb on the L16u cabinet.
- Do not block the ventilation holes used for air circulation.
- Do not overload objects on the L16u cabinet (maximum loading is 130lb).
- Before moving L16u cabinet, disconnect the power from the wall outlet.
- It is recommended to use at least two people and lift from the bottom when moving the L16u cabinet.

Contents

I.	INTRODUCTION	1
	Package Contents	1
	Cabinet Dimensions	1
	Cabinet Diagram	2
	Door Lock	3
	LED Status	3
II.	SETUP	4
	Daisy-Chaining	8
III.	SPECIFICATIONS	9

I. Introduction

Package Contents

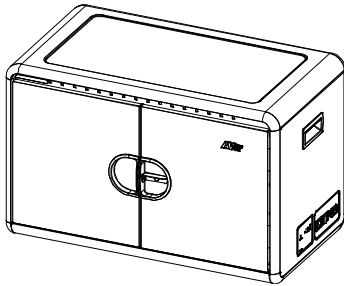

L16u Cabinet

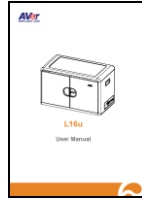

User manual

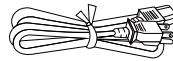

Power cord

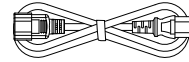

Power daisy chain cable

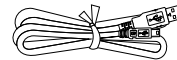

Sync. daisy chain cable*

* The sync. daisy chain cable can be used either directly connecting to laptop, or connection to other L16u cabinet for data daisy-chain synchronization.

Cabinet Dimensions

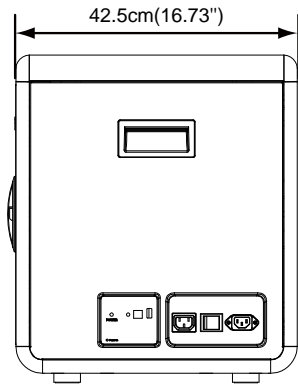
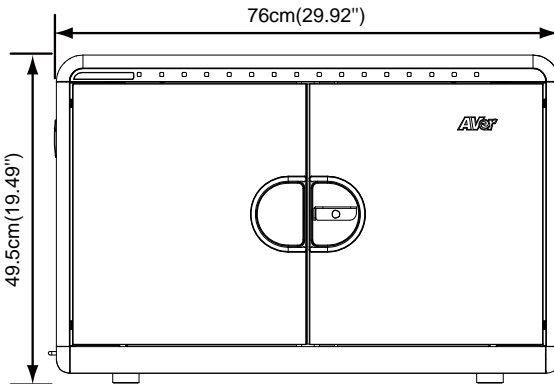

Cabinet Diagram

Front

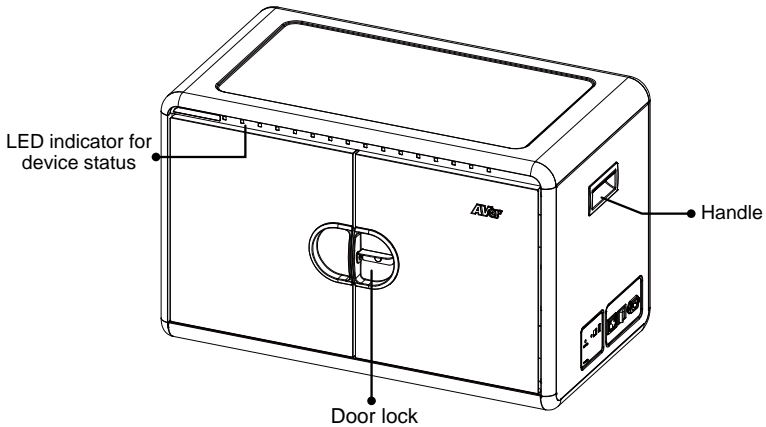

Side

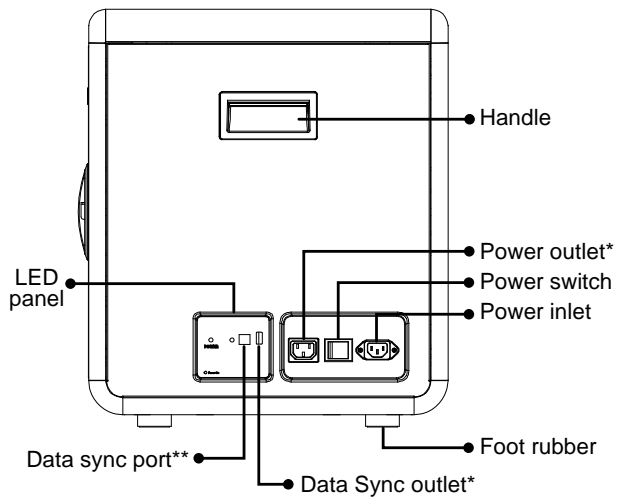

*Use for synchronize daisy-chain when connecting multiple cabinets.

*Use for connecting to other cabinet's data sync port during data daisy-chain synchronization.

*Connect to laptop's USB port, or other cabinet's data sync outlet during data daisy-chain synchronization.

** Use as Synchronize Daisy-Chain inlet when connecting multiple cabinets.

[Note] Maximum daisy-chain 3 cabinets together.

Back

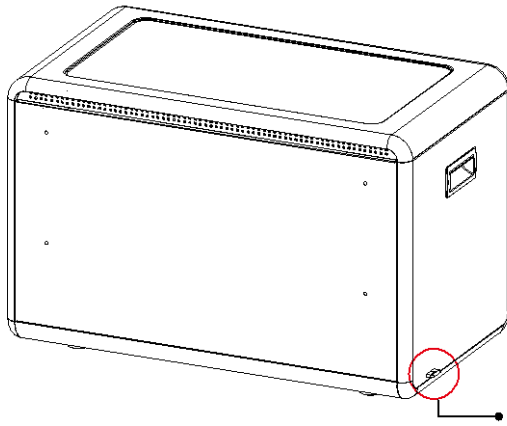

Inner dimensions of security hook(max.)

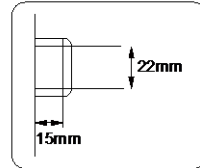

Door Lock

[Note] The shackle dimension is limited to Ø8mm (0.31").

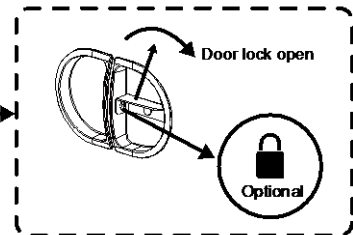
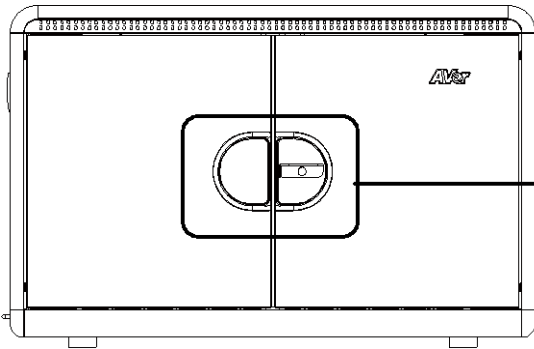

LED Status

LED	Description
Power (x1)	■ OFF: Power OFF
	■ Solid Green: Power ON
USB Sync LED (x1)	■ Solid Blue: Data Sync Cable is connected
	■ Red: Charging
Device Status (x16)	■ Solid Green: Fully Charged
	■ Flashing Green: Sync in Progress

II. Setup

- ① Open the front doors.

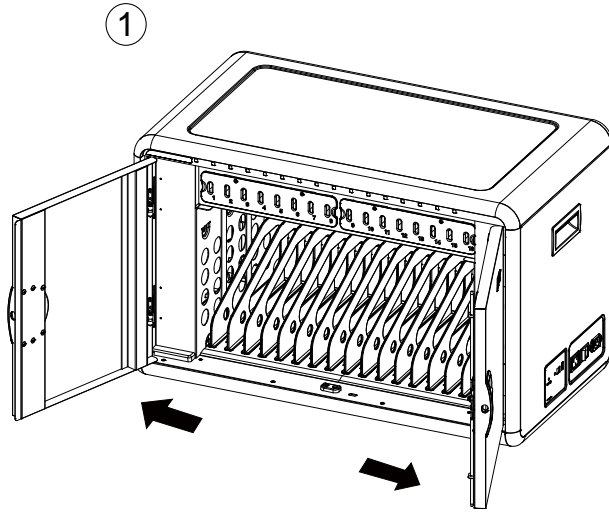

- ② Release the screws of cable management slot.

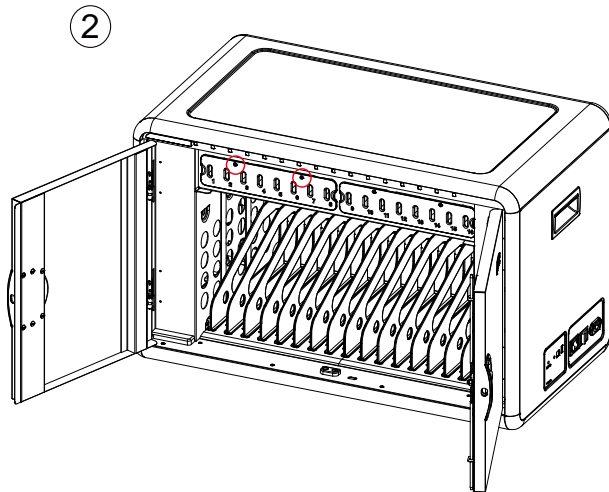

- ③ Remove the cable management slot from L16u cabinet.

③

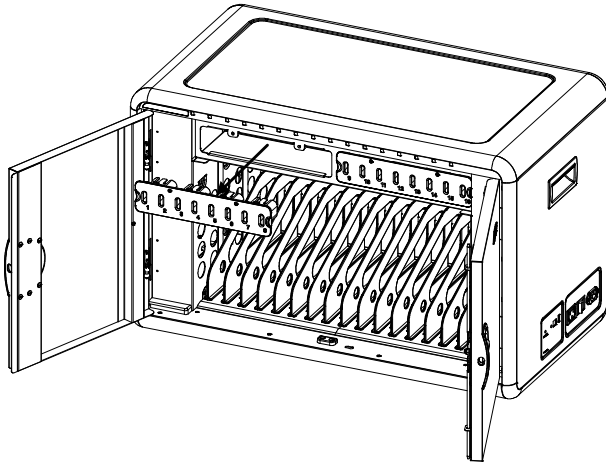

- ④ Fold the power cable of iPad or tablets and adjust the length of cable for connecting to devices and USB port of cabinet. Insert the power cable of through the hole (as below figure shown); Wrap double cable along the groove as the below figure to fix the power cable. After fixing power cable, the extra power cable can store in the near slot.

④

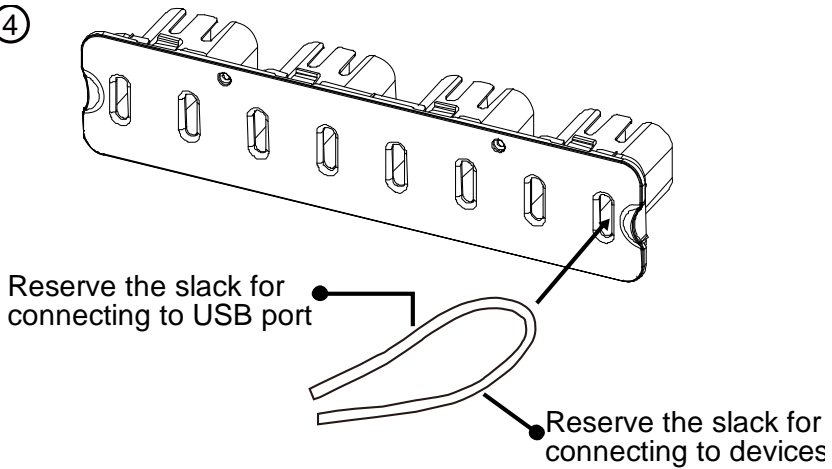

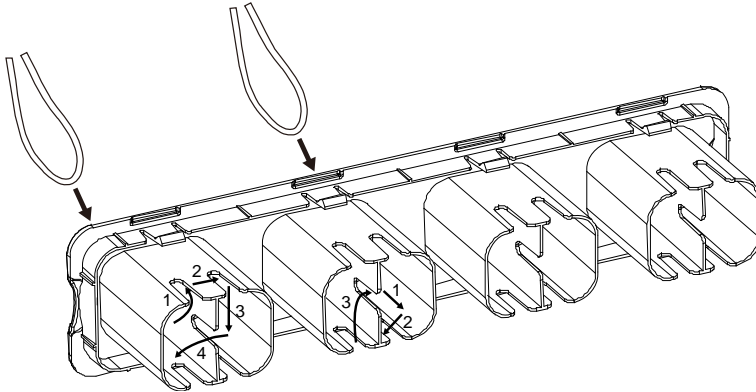

- ⑤ Put the cable management slot back to the cabinet and screw it tight.
- ⑥ Connect the power cable to devices.
- ⑦ Connect the USB connector of power cable to USB port of cabinet.

⑦

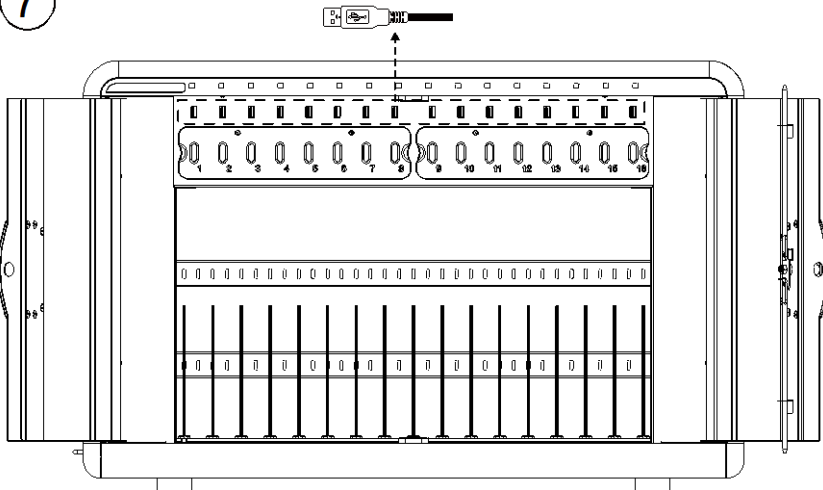

- ⑧ If the slot width needs to be adjusted, remove the divider to the corresponding position.
- ⑨ Close front door.

Charging L16u cabinet

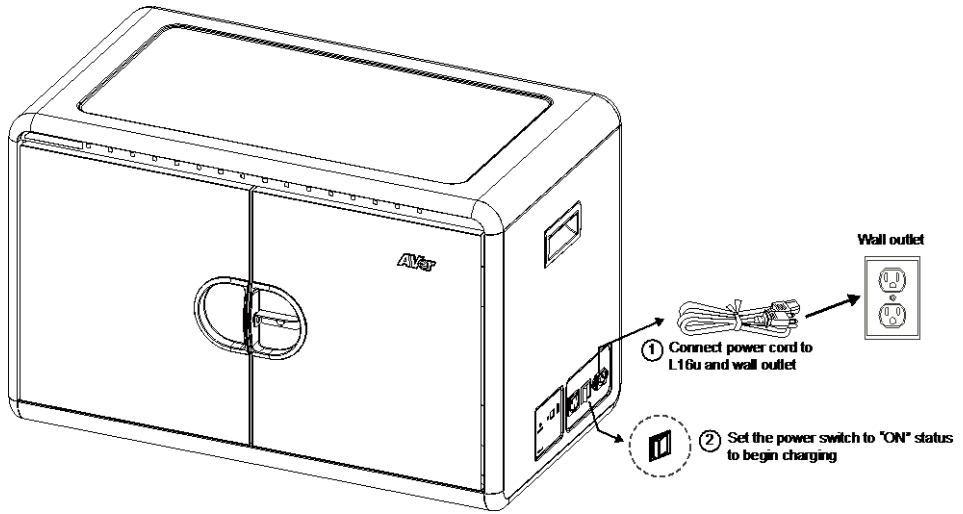

Daisy-Chaining

The L16u cabinet supports power and synchronizes Daisy-Chain technology. Power Daisy-Chain enables total maximum 3 cabinets to charge through a single wall outlet. Through sync Daisy-Chain, all the devices in the cabinets can be synchronized at once.

The configuration of Daisy-Chain is illustrated below.

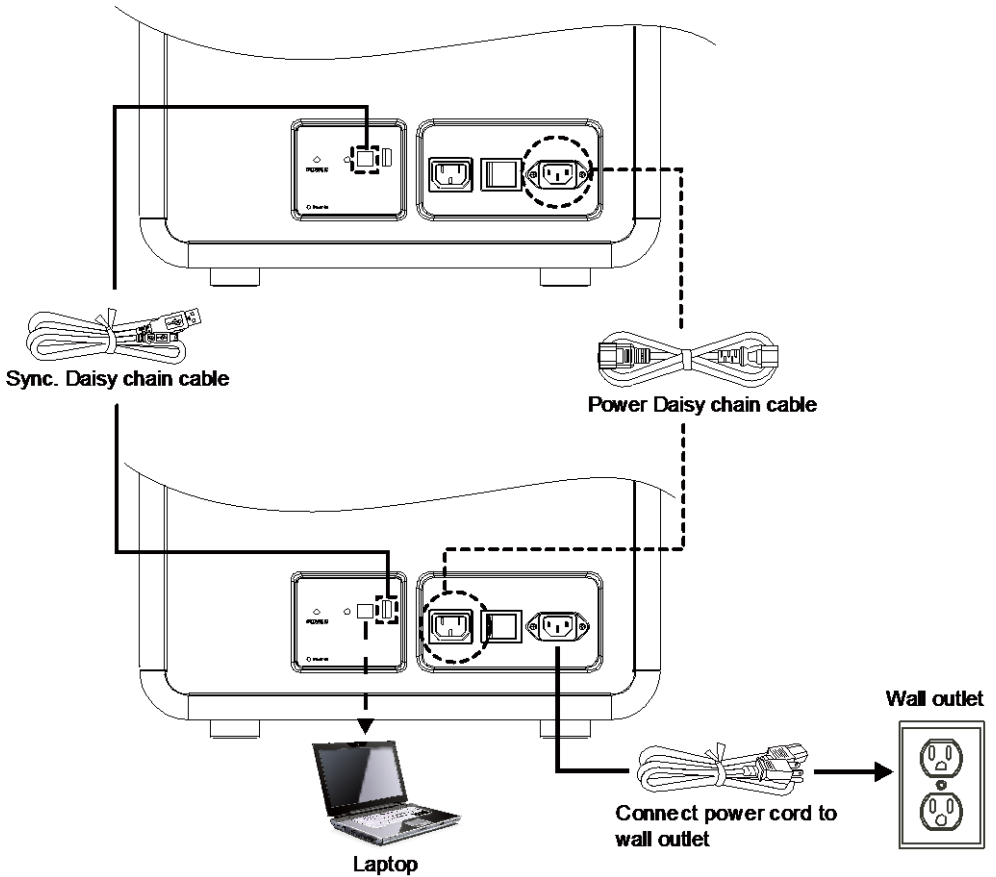

III. Specifications

Capacity	16
Device support	All USB-charged tablets
Slot Dimension (W x D x H)	2.8(W) x 36.4(D) x 28.5(H) cm 1.10"(W) x 14.33"(D) x 11.22"(H) * The divider is adjustable
LED status indicators	Yes
Charging type	USB 2.0
Power specification	AC Input: 100-120V ~ 50/60Hz, 12A 220-240V ~ 50/60Hz, 8A Output for 16 USB ports: DC 5V, 2.1A
Security	Front door: 3-point locking mechanism
Security hook	Yes
Working temp.	0 ~ 30°C
Working RH	10% ~ 90%
Storage temp.	-40°C ~ 60°C
Storage RH	5% ~ 95%
Warranty	10-year limited warranty for cabinet and tray 5-year limited warranty for electrical parts
Dimensions(W x D x H)	76(W) x 42.5(D) x 49.5 (H)cm 29.92"(W) x 16.73"(D) x 19.49"(H)

